



CITY PLAN COMMISSION STAFF REPORT

City of Kansas City, Missouri
City Planning & Development Department
www.kcmo.gov/cpc

8/07/2024

Project Name

Swope Health Village Campus

Docket # 7.1 & #.2

Request

CD-CPC-2024-00073
Area Plan Amendment

CD-CPC-2024-00072
Rezoning to MPD + Development Plan

Applicant

BHC Rhodes
William Buck

Owner

City of Kansas City

Swope Health Services
3801 Dr Martin Luther King Jr Blvd

Location ~3427 E 59th St
Area About 11.05 Acres
Zoning R-1.5
Council District 5
County Jackson
School District KCMO 110

Surrounding Land Uses

North: Residential Uses, zoned R-2.5
South: Residential Uses, zoned R-2.5
East: Commercial Uses, zoned B1-1
West: Residential Uses, zoned R-1.5

KC Spirit Playbook Alignment

CD-CPC-2024-00072 & 73
LRP determination: Likely

Land Use Plan

The Swope Area Plan recommends Future Residential Medium-High Density for this location.

Major Street Plan

Swope Parkway is identified as an Established Parkway on the City's Major Street Plan.

APPROVAL PROCESS**PROJECT TIMELINE**

The application for the subject request was filed on 05/28/2024. Scheduling deviations from 2024 Cycle 7.2 have occurred.

- Revised plans submitted 7/22, a third round of city staff reviews needed.

NEIGHBORHOOD AND CIVIC ORGANIZATIONS NOTIFIED

The subject site is located within the Town Fork Creek Neighborhood Association.

REQUIRED PUBLIC ENGAGEMENT

Public engagement as required by 88-505-12 does apply to this request. The applicant hosted a meeting on 6/26/2024. A summary of the meeting is attached to the staff report, see Attachment #3.

EXISTING CONDITIONS

A majority of the site is currently vacant, in preparation for the proposed project.

SUMMARY OF REQUEST + KEY POINTS

The applicant is seeking approval of a rezoning to MPD (Master Planned Development), with an associated preliminary development plan, to develop a mixed-housing campus with associated amenities.

PROFESSIONAL STAFF RECOMMENDATION

Docket #7.1 Area Plan Amendment Approval
Docket #7.2 MPD Rezoning + Development Plan Approval, Subject to Conditions

CONTROLLING + RELATED CASES

240455

Authorizing the City Manager to negotiate and execute a development agreement with Swope Health Services or an affiliated entity for the property located at 5900 Swope Parkway, in Kansas City, Missouri, estimating revenue from the sale of property and appropriating funds to defease outstanding bonds; appropriating \$5,000,000.00 from the unappropriated fund balance of the Health Fund as a contribution toward redevelopment of the site; authorizing the Director of Finance to execute an escrow agreement and related documents; approving the selection of Kutak Rock LLP and Hardwick Law Firm as defeasance counsel for this matter; and directing the City Manager to negotiate and execute an agreement with Swope Health Services, an affiliated entity, or its successor to reserve up to ten behavioral health beds at the future facility for referrals from the Municipal Court.

PLAN REVIEW

The MPD, Master Planned Development, district is intended to accommodate development that may be difficult, if not impossible, to carry out under applicable zoning district standards. The proposed Mixed-Use Development MPD for a housing plus health services campus.

MPDs must promote specific planning objectives. The proposed MPD promotes the following objectives (4/8),

- 1. flexibility and creativity in responding to changing social, economic, and market conditions that result in greater public benefits than could be achieved using conventional zoning and development regulations.
- 4. sustainable, long-term communities that provide economic opportunity and environmental and social equity for residents.
- 5. variety in housing types and sizes to accommodate households of all ages, sizes, incomes, and lifestyle choices.
- 8. compatibility of buildings and other improvements as determined by their arrangement, massing, form, character, and landscaping to establish a high-quality livable environment.

PLAN ANALYSIS

Commercial Lot and Building (88-120), Use- Specific (88-300), and Development Standards (88-400)

**indicates adjustment/deviation*

Standards	Applicability	Meets	More Information
Lot and Building Standards	No	-	See the site plan for MPD Lot and Building Standards.
Accessory or Use- Specific Standards (88-305 – 385)	No	-	-
Boulevard and Parkway Standards (88-323)	Yes	-	See the Conditions Report.
Parkland Dedication (88-408)	Yes	-	See the Conditions

			Report.
Tree Preservation and Protection (88-424)	Yes	Yes	See the Conditions Report.
Parking and Loading Standards (88-420)	Yes	Yes	See the Site Plan
Landscape and Screening Standards (88-425)	Yes	Yes	See the Site Plan
Outdoor Lighting Standards (88-430)	Yes	Yes	See the Conditions Report.
Sign Standards (88-445)	Yes	-	See the Conditions Report.
Pedestrian Standards (88-450)	Yes	Yes	See the Site Plan.

SPECIFIC REVIEW CRITERIA

Development Plans, Project Plan, or Site Plan (88-516-05)

In order to be approved, a development plan, project plan, or site plan must comply with all of the following criteria:

A. The plan must comply with all standards of the Zoning and Development Code and all other applicable city ordinances and policies;

- No deviations from the Zoning and Development Code are being requested/needed. *AN*
- The proposed project accompanies an area plan amendment; amending the Swope Area Plan from Residential Medium-High Density to Mixed-Use Community. The Swope Area Plan calls for the revitalization of properties oriented to boulevards and parkways to catalyze revitalization efforts. This development would act as a catalyst for further development along Swope Parkway. This project would add residential units along Swope Parkway, which adds residents to the area and can encourage additional neighborhood-oriented commercial businesses. *JF*

B. The proposed use must be allowed in the district in which it is located;

Use	R-1.5	Notes
Group Living	SUP	The MPD allows for the uses listed to be combined on-site.
Community Center	P/SUP	
Senior Housing (multi-unit structures, nursing homes)	P	
Office - Medical	-	
Office – General	SUP	

C. Vehicular ingress and egress to and from the site, and circulation within the site must provide for safe, efficient, and convenient movement of traffic not only within the site but on adjacent roadways;

With the vehicular ingress and egress to and from the site being located on 59th and 60th St, traffic is efficient on adjacent roadways. Pedestrian campus-style circulation is prioritized over vehicular connections, thus proposed parking lots are not connected. *AN*

D. The plan must provide for safe, efficient, and convenient non-motorized travel opportunities, being pedestrian and bicycle movement, on the subject site;

Safe, efficient, and convenient non-motorized travel opportunities are proposed on the subject site. The internal pedestrian network contributes to the campus-style environment and details about the bicycle parking will accompany the Final MPD Plan. AN

E. The plan must provide for adequate utilities based on City standards for the particular development proposed.

Except for Public Works, the appropriate city divisions/departments responsible for ensuring that public facilities and services are connected/available to serve the development have reviewed the project. AN

F. The location, orientation, and architectural features, including design and material, of buildings and other structures on the site must be designed to be compatible with adjacent properties.

The location, orientation, and architectural features of the proposed project do not match the adjacent properties. However, with the high-quality design standards proposed, a unique activity center will not be a detriment to the neighborhood. AN

G. Landscaping, berms, fences, and/or walls must be provided to buffer the site from undesirable views, noises, lighting, or other off-site negative influences and to buffer adjacent properties from negative influences that may be created by the plan.

The proposed project buffers the site appropriately. More details, if any, about lighting and fences will be reviewed on the Final MPD Plan. AN

H. The design of streets, drives, and parking areas within the project should result in a minimum of area devoted to asphalt or other impervious surfaces consistent with the needs of the project and city code requirements.

The design of drives and parking areas within the proposed project is appropriate for a mixed housing-health services campus. AN

I. The plan must identify trees to be removed and trees to be preserved during the development of the subject property with the goal of saving trees that are not required to be removed for the development of the property.

N/A. The proposed project proposes additional landscaping and trees to support a healthy campus environment. AN

Master Planned Developments (88-520-03-G)

In reviewing and making decisions on proposed MPD rezonings and preliminary development plans, review and decision-making bodies must consider at least the following factors:

A. The preliminary development plan's consistency with any adopted land use plans for the area;

See the Development Plan review criteria A above. AN

B. The preliminary development plan's consistency with the MPD district provisions of 88-280; and

Yes, see the Plan Review above. AN

C. The sufficiency of the terms and conditions proposes to protect the interest of the public and the residents of the MPD in the case of a plan that proposes development over a long period of time.

The terms and conditions associated with the project are appropriate for a mixed housing campus focused on health services. Thus, the phasing plan considers growth and the site's needed amenities over a long period of time. AN

ATTACHMENTS

1. Conditions Report
2. Applicants Submittal
3. Public Engagement Materials
4. Additional documents, if applicable [N/A]
5. KC Spirit Alignment (Attached to CompassKC)

PROFESSIONAL STAFF RECOMMENDATION

City staff recommends **APPROVAL** and **APPROVAL, SUBJECT TO CONDITIONS** as stated in the conditions report.

The following needs to be resolved prior to the City Council ordinance request.

1. Identify the following uses in the site data table, senior living (includes multi-unit residential and nursing homes), office – medical, and office – general.
2. Update the site data table to reflect vehicle and bicycle parking counts per 88-420.

Respectfully Submitted,

Ahnna Nanoski, AICP
Planning Supervisor



Plan Conditions

Report Date: July 30, 2024

Case Number: CD-CPC-2024-00072

Project: Swope Health Village Campus

Condition(s) by City Planning and Development Department. Contact Ahnna Nanoski at (816) 513-8816 / Ahnna.Nanoski@kcmo.org with questions.

1. All building facades shall comply with 88-323-02-E.
2. No detailed sign plan was provided. All signage must comply with 88-445 (non-residential development/district).
3. The developer shall secure approval of an MPD Final Plan for each phase identified on the approved MPD Plan from the City Plan Commission prior to building permit.
4. Walls and fences proposed on the subject site must comply with residential standards identified in Chapter 27 and Chapter 88 of the municipal code.
5. All mechanical equipment, dumpsters, and utility cabinets shall comply with 88-323-02-D and 88-425-08, to be detailed in the final MPD Plan for each phase proposed on the adopted plans.
6. Wayfinding signage along 59th St, Swope Parkway, and 60th St will be installed to direct pedestrian traffic into the campus. Signs must comply with 88-445 and identified in the Final MPD Plans.
7. "No Idling" or "Idle-Free Zone" signs must be posted in all off-street loading areas.
8. The developer shall submit an affidavit, completed by a landscape architect licensed in the State of Missouri, verifying that all landscaping and trees required of the approved plan has been installed in accordance with the plan and is healthy prior to Certificate of Occupancy.
9. The developer shall submit an affidavit, prepared by an engineer licensed in the State of Missouri, verifying that all outdoor lighting has been installed in accordance with approved plans and that lighting levels do not exceed that shown on the approved lighting plan at the property lines prior to Certificate of Occupancy.
10. The following corrections need to be resolved prior to the City Council ordinance request.
 1. Identify the following uses in the site data table, senior living (includes multi-unit residential and nursing homes), office—medical, and office - general.
 2. Update the site data table to reflect vehicle and bicycle parking counts per 88-420.

Condition(s) by Fire Department. Contact Michael Schroeder at (816) 513-4604 / michael.schroeder@kcmo.org with questions.

11. The developer shall meet the fire flow requirements as set forth in Appendix B of the project International Fire Code 2018. (IFC-2018 § 507.1)
12. The turning radius for fire department access roads shall be 30 feet inside and 50 feet outside radius. (IFC-2018: § 503.2.4) This condition must be detailed in the Final MPD Plan.
13. Fire hydrants shall be installed and operable prior to the arrival of any combustible building materials onto the site. (IFC-2018 § 501.4 and 3312.1; NFPA 241-2013 § 8.7.2)

Fire hydrant distribution shall follow IFC-2018 Table C102.1

Condition(s) by Fire Department. Contact Michael Schroeder at (816) 513-4604 / michael.schroeder@kcmo.org with questions.

14. A required fire department access roads shall be an all weather surface. (IFC-2012: § 503.2.3)

Fire Department access roads shall be provided prior to construction/demolition projects begin. (IFC-2018 § 501.4 and 3310.1; NFPA 241-2013 § 7.5.5)

Required fire department access roads shall designed to support a fire apparatus with gross axle weight of 85,000 pounds. (IFC-2018: § 503.2.3)

This condition must be detailed in the Final MPD Plan.

- Shall provide fire lane signage on fire access drives.

15. Aerial Fire Apparatus access roads shall be provided for any building that is 30 feet in height or greater. Aerial Fire Apparatus Roads are a minimum 26 feet wide, at least 15 feet away from the building but not more than 30 feet from the structure. (IFC-2018 § D105). This condition must be detailed in the Final MPD Plan.

- Buildings exceeding three (3) stories or 30 feet in height shall have at least two means of fire apparatus access. (IFC-2018: § D104.1)

16. Buildings equipped with a fire standpipe system shall have an operable fire hydrant within 100 feet of the Fire Department Connection (FDC). (IFC2018 § 507.5.1.1)

17. Buildings exceeding 62,000 square feet in area shall have at least two means of fire apparatus access (IFC-2018: § D104.2)

18. New buildings shall have approved radio coverage for emergency responders within the building based on the existing coverage levels of the public safety communication systems utilized by the jurisdiction, measured at the exterior of the building. This section shall not require improvement of the existing public safety communication systems. (IFC 2018 510.1) and (NFPA1221)

19. Approved fire apparatus access roads shall be provided for every facility, building or portion of a building hereafter constructed or moved into or within the jurisdiction. The fire apparatus access road shall comply with the requirements of this section and shall extend to within 150 feet (45 720 mm) of all portions of the facility and all portions of the exterior walls of the first story of the building as measured by an approved route around the exterior of the building or facility. (IFC-2018 § 503.1.1) This condition must be detailed in the Final MPD Plan.

Condition(s) by Parks & Recreation. Contact Richard Sanchez at (816) 513-7678 / Richard.Sanchez@kcmo.org with questions.

20. The developer shall be responsible for dedication of parkland, private open space in lieu of parkland, or payment of cash-in-lieu of either form of dedication, or any combination thereof in accordance with 88-408. Should the developer choose to pay cash-in-lieu of dedicating all or a portion of the required area, the amount due shall be based upon the 2024 acquisition rate of \$64,220.18 per acre. This requirement shall be satisfied prior to certificate of occupancy.

21. The developer shall submit plans to Parks & Recreation Department and obtain permits prior to beginning construction of streetscape improvements (including but not limited to sidewalks, curbs, gutters, streetscape elements, pedestrian and street lighting) on the Parks jurisdictional streets and construct improvements, ADA compliant ramps at all required locations where new private drives are being added, or where existing sidewalks are modified or repaired. Such improvements shall be installed per Parks & Recreation Department Standards

22. The developer shall submit a letter to the Parks and Recreation Department from a Licensed Civil Engineer, Licensed Architect, or Licensed Landscape Architect, who is registered in the State of Missouri, stating the condition of the sidewalks, curbs, and gutters along boulevard/parkway, which is a parks and recreation jurisdictional street. The letter shall identify state of repair as defined in Chapters 56 and 64 of the Code of Ordinances for the sidewalks, curbs, and gutters. It shall identify the quantity and location of sidewalks, curbs, gutters that need to be constructed, repaired, or reconstructed. The developer shall secure permits to repair or reconstruct the identified sidewalks, curbs, and gutters as necessary along all development street frontages, as required by the Parks and Recreation Department, prior to recording the plat/issuance of any certificate of occupancy permits including temporary certificate occupancy permits

23. The developer shall submit a streetscape plan with street tree planting plan per 88-425-03 for approval and permitting by the Parks & Recreation Department's Forestry Division prior to beginning work in the public right-of-way

24. Prior to construction adjacent to a parks and recreation jurisdictional street and/or park the developer and/or their representative shall obtain a parks permit for storage and restoration within a park or a parks and recreation jurisdictional street right-of-way including but not limited to the installation of construction trailer, stockpiling of materials or equipment, construction roads and utility cabinets/meters.

Condition(s) by Parks & Recreation. Contact Richard Sanchez at (816) 513-7678 / Richard.Sanchez@kcmo.org with questions.

25. All structures located along Swope Parkway shall have a main entrance facing the parkway or an additional setback will be required. This entrance shall also include a pedestrian connection from the structure to the perimeter sidewalk.
26. The applicant shall meet all requirements of the Parkway and Boulevard Standards per section 88-323.

Condition(s) by Public Works Department. Contact Terry Thomas at (816) 513-2510 / Terry.A.Thomas@kcmo.org with questions.

27. The developer shall submit a streetscape plan for approval and permitting by the Land Development Division prior to beginning construction of the streetscape improvements in the public right of way, and construct ADA compliant ramps at all required locations where new private drives are being added, or where existing sidewalks are modified or repaired.
28. The developer shall submit plans for grading, siltation, and erosion control to Land Development Division for review and acceptance, provide a copy of the Storm Water Pollution Prevention (SWPP) plan submitted to the Missouri Dept. of Natural Resources (MDNR) and secure a Site Disturbance permit for any proposed disturbance area equal to one acre or more prior to beginning any construction activities.
29. The developer shall integrate into the existing street light system any relocated existing street lights within the street right-of-way impacted by the new drive or approach entrances as required by the Land Development Division, and the relocated lights must comply with all adopted lighting standards.
30. The developer shall submit a letter to the Land Development Division from a Licensed Civil Engineer, Licensed Architect, or Licensed Landscape Architect, who is registered in the State of Missouri, that identifies sidewalks, curbs, and gutters in disrepair as defined by Public Works Department's "OUT OF REPAIR CRITERIA FOR SIDEWALK, DRIVEWAY AND CURB revised 11/5/2013" and based on compliance with Chapters 56 and 64 of the Code of Ordinances for the sidewalks, curbs, and gutters where said letter shall identify the quantity and location of sidewalks, curbs, gutters that need to be constructed, repaired, or reconstructed to remedy deficiencies and/or to remove existing approaches no longer needed by this project. The developer shall secure permits to repair or reconstruct the identified sidewalks, curbs, and gutters as necessary along all development street frontages as required by the Land Development Division and prior to issuance of any certificate of occupancy permits including temporary certificate occupancy permits.
31. The developer shall submit verification of vertical and horizontal sight distance for the drive connection to public right-of-way to the Land Development Division and make improvements to ensure local jurisdiction and/or minimum AASHTO adequate sight distance standards are met, prior to issuance of any certificate of occupancy.

Condition(s) by Water Services Department. Contact Heather Massey at (816) 513-2111 / heather.massey@kcmo.org with questions.

32. Water/Sewer Service lines shall serve only one lot or tract and shall not cross a separate lot or tract.
33. The developer shall ensure that water and fire service lines should meet current Water Services Department Rules and Regulations. Prior to C of O.
<https://www.kcwater.us/wp-content/uploads/2022/05/2022-Rules-and-Regulations-for-Water-Service-Lines-Final.pdf>
34. The developer shall have a water flow test done to ensure there is adequate water pressure to serve the development.
South of River contact - Patrick Lewis 816-513-0423
North of River contact - Todd Hawes 816-513-0296
35. No water service line will be less than 1-1/2" in diameter where three or more units or Commercial building will be served by one domestic service line and meter.
36. Branch service lines one-and-one-half inches and larger in diameter for domestic water services or fire protection lines shall be connected to the main by cutting in a minimum 6" branch service tee, installing three gate valves, and two solid sleeves on the main. Line valves on the main shall be the same nominal size as the main.

Condition(s) by Water Services Department. Contact Kirk Rome at (816) 513-0368 / kirk.rome@kcmo.org with questions.

37. The existing water main in 59th Street was recently upsized to 8" and is now reflected as such in the Water GIS maps. It is not anticipated that public water main extension plans will be needed, however this assumption should be confirmed with a comparative analysis of the available flow and pressure to the expected demand generated. If the water mains need to be upsized they will need to meet KC Water Rules and Regulations.

Condition(s) by Water Services Department. Contact Lucas Kaspar at (816) 513-2131 / Lucas.Kaspar@kcmo.org with questions.

Condition(s) by Water Services Department. Contact Lucas Kaspar at (816) 513-2131 / Lucas.Kaspar@kcmo.org with questions.

38. The developer shall submit an analysis to verify adequate capacity of the existing sewer system as required by KC Water prior to issuance of a building permit to connect private system to the public sewer main and depending on adequacy of the receiving system, make other improvements may be required.
39. The owner/developer must submit plans for grading, siltation, and erosion control to KC Water for review and acceptance, and secure a Site Disturbance permit for any proposed disturbance area equal to one acre or more prior to beginning any construction activities.
40. The developer shall submit a Storm Drainage analysis from a Missouri-licensed civil engineer to KC Water evaluating proposed improvements and impact to drainage conditions. Since this project is within a "Combined Sewer Overflow" (CSO) district, the project shall be designed to retain rainfall of 1.5 inch depth over the disturbed area to simulate natural runoff conditions and reduce small storm discharge to the combined sewer system. Manage the 10-year storm and 100-year storm per currently adopted APWA standards. The analysis shall be submitted, and the developer shall secure permits to construct any improvements required by KC Water prior to recording the plat.
41. The developer shall cause the area to be platted and processed in accordance with Chapter 88, Code of Ordinances of the City of Kansas City, Missouri, as amended, commonly known as the Development Regulations.

SWOPE VILLAGE CAMPUS MASTER PLANNED DEVELOPMENT

KANSAS CITY, MO

3427 E 59TH STREET, AND 5900, 5924, 5926, 5930 SWOPE PARKWAY
MASTER PLAN DEVELOPMENT AND AREA PLAN AMENDMENT

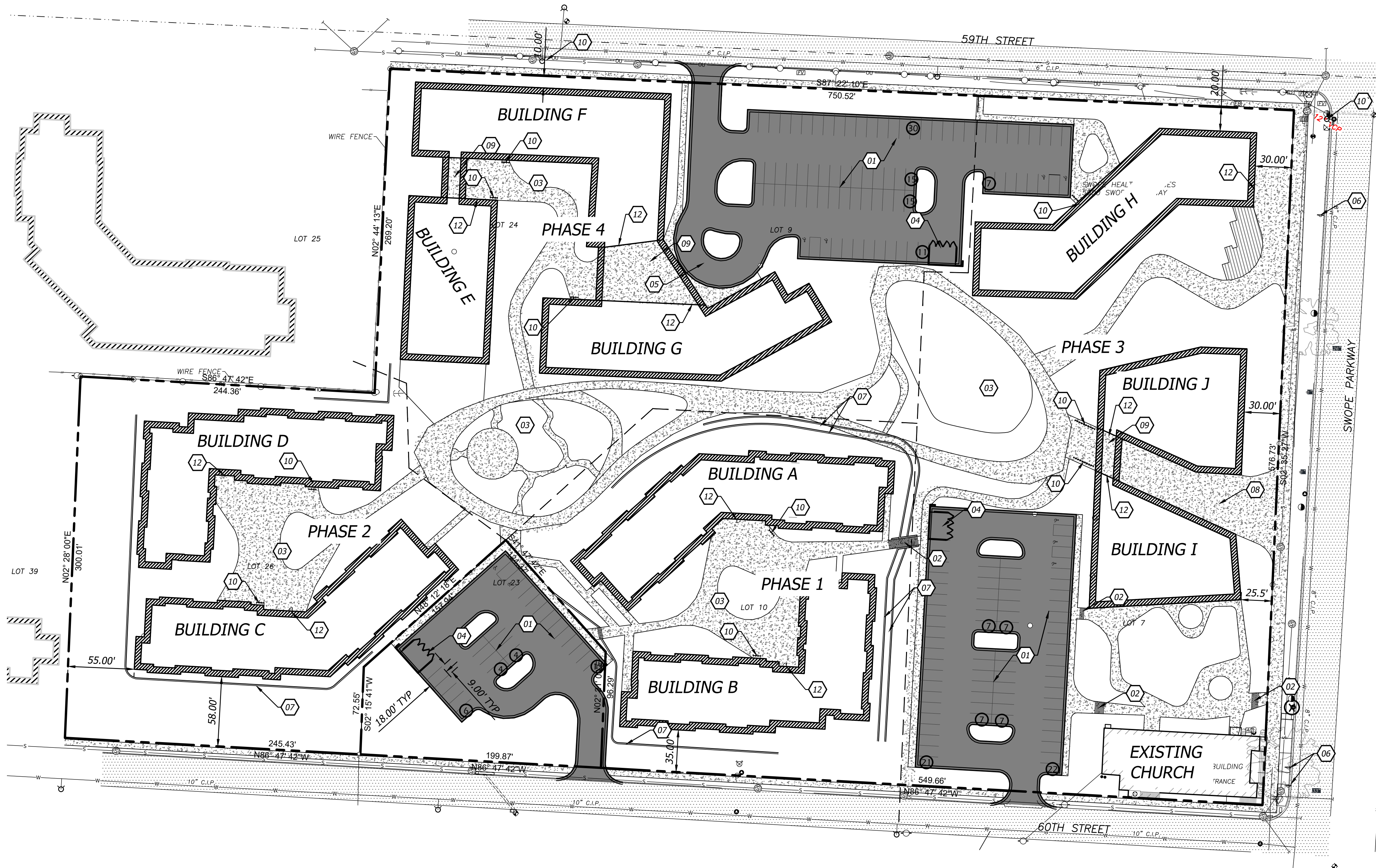

SITE DATA

SITE		11.05	AC
SITE AREA:		481,357	SF
IMPERVIOUS AREA:			
EXISTING:		211,174	SF 43.9%
PROPOSED:		315,879	SF 65.6%
ZONING			
EXISTING:		R1.5	
PROPOSED:		MPD	
PHASE 1			REQ'D
BUILDING A:	GROUP LIVING	16,200	SF 9.0
BUILDING B:	GROUP LIVING	15,823	SF 9.0
PARKING:	STANDARD	25	18.0
	ADA	2	
PHASE 2			
BUILDING C:	GROUP LIVING	15,611	SF 9.0
BUILDING D:	GROUP LIVING	15,227	SF 9.0
PARKING:	STANDARD	7	18.0
	ADA	0	
PHASE 3			
BUILDING H:	SENIOR HOUSING	15,881	SF 16.3
BUILDING J:	COMMUNITY CENTER	10,236	SF 25.6
BUILDING I:	COMMUNITY CENTER	10,218	SF 25.5
PARKING:	STANDARD	68	68.0
	ADA	3	
PHASE 4			
BUILDING E:	SENIOR HOUSING	10,000	SF 10.4
BUILDING F:	SENIOR HOUSING	17,077	SF 10.4
BUILDING G:	SENIOR HOUSING	14,030	SF 10.4
PARKING:	STANDARD	74	32.0
	ADA	4	

CONSTRUCTION NOTES

- 01 PARKING LOT STRIPING
- 02 PROPOSED STAIRS
- 03 PROPOSED COURTYARD FOR SWOPE HEALTH CAMPUS RESIDENTS
- 04 PROPOSED TRASH ENCLOSURE
- 05 VEHICLE LOADING ZONE
- 06 PROTECT EXISTING BUS ROUTE SIGN
- 07 PROPOSED RETAINING WALL
- 08 PROPOSED GATEWAY INTO SWOPE HEALTH CAMPUS
- 09 PROPOSED ROOF TOP COVERING/AERIAL HALLWAY BETWEEN BUILDING
- 10 BICYCLE PARKING
- 11 EXISTING FIRE HYDRANT
- 12 BUILDING MAIN ENTRANCE LOCATION

SITE LEGEND

- PROPOSED BUILDING
- EXISTING BUILDING
- MEDIUM DUTY ASPHALT PAVEMENT
- CONCRETE SIDEWALK
- CONCRETE DUMPSTER PAD
- "INVERTED U" BICYCLE PARKING
- PROPERTY LINE
- PARKING STALL COUNT
- PHASE SEPARATION LINE

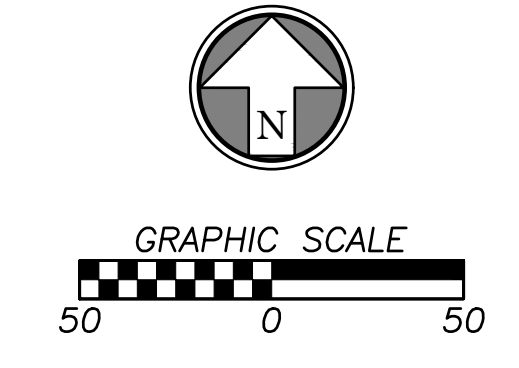

Jun 24, 2024 3:17pm Plotted By: matt.gibbs V:\039350--swope_village_campus\04-DWG\Eng\Sheet\PDF\039350-SWHS-SITE-SITE-PDP.dwg Layout: C1.0 OVERALL SITE PLAN

	By: App.
	Date
	Rev.
	Description
<p style="font-size: small; margin: 0;">BHC BIOETHICS & HEALTH CARE 101 Cliff Brk., Ste. 400 Overland Park, Kansas 66210 p. (913) 663-1900 BHC is a subsidiary of Evangelical Heritage Company, P.A.</p>	
<p style="font-size: x-small; margin: 0;">Prepared For:</p> <p style="margin: 0;">SWOPE HEALTH 3801 DR. MARTIN LUTHER KING JR. BLVD KANSAS CITY, MO 64130 816-923-5800</p>	
<p style="font-weight: bold; margin: 0;">SWOPE VILLAGE CAMPUS 5900 SWOPE PARKWAY KANSAS CITY, MO, 64613</p> <p style="font-weight: bold; margin: 0;">OVERALL SITE PLAN</p>	
<p>Design: MGG Drawn: LAS Checked: MGG Issue Date: 05/28/2024 Project Number: 039350</p>	
C1.0	

PRELIMINARY PLAT

SWOPE PARK HIGHLANDS REPLAT

LOTS 7, 8, 9, 10, 23, 24, 26, PART OF 39

KANSAS CITY, MO

3427 E 59TH STREET, AND 5900, 5924, 5926, 5930 SWOPE PARKWAY

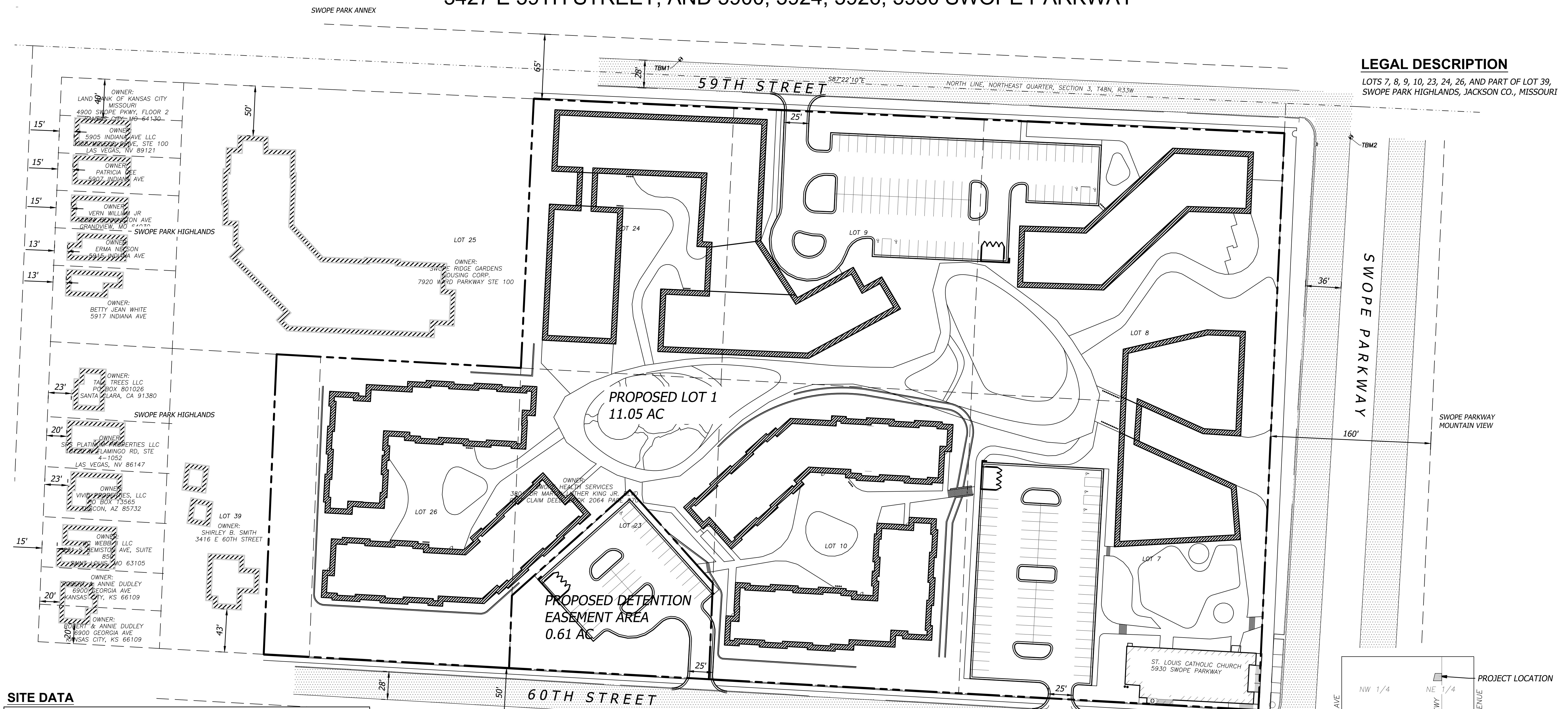

LEGAL DESCRIPTION
 LOTS 7, 8, 9, 10, 23, 24, 26, AND PART OF LOT 39,
 SWOPE PARK HIGHLANDS, JACKSON CO., MISSOURI

SITE DATA

SITE:	11.05 ± AC
GROSS PROJECT AREA	R-1.5 RESIDENTIAL
EXISTING ZONING	MPD MASTER PLANNED
PROPOSED ZONING	01
PROPOSED NUMBER OF LOTS	0.09 LOTS/ACRE
PROPOSED DENSITY	N/A
STREET CLASSIFICATION	N/A FEET
RIGHT-OF-WAY WIDTH	N/A FEET BACK-TO-BACK
PAVEMENT WIDTH	2.95 AC
PARKLAND DEDICATION	N/A UNITS
DETACHED HOUSING	N/A UNITS
SEMI-ATTACHED HOUSING	72 UNITS
MULTI-UNIT BUILDING	174 UNITS
BEHAVIORAL HEALTH	
SENIOR HOUSING	

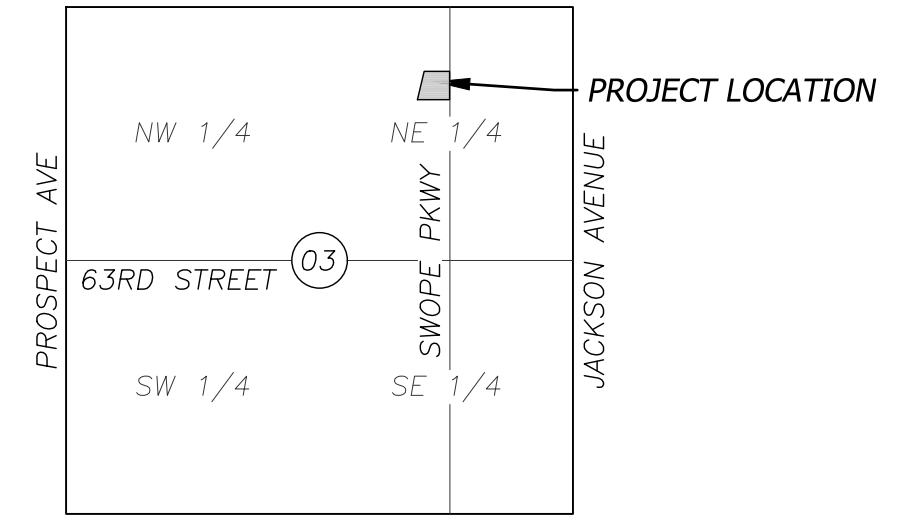
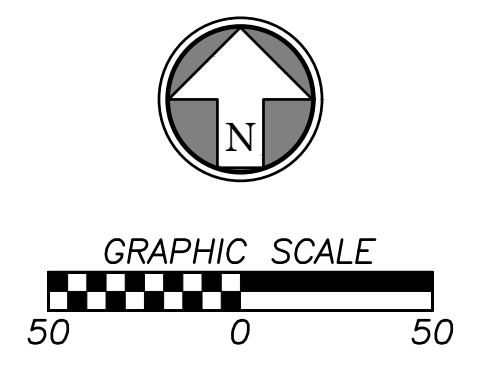
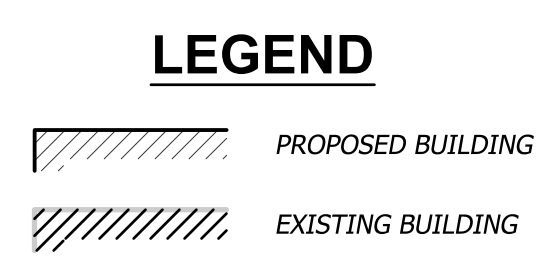

SECTION MAP
 NOT TO SCALE
 SECTION 03-T48N-R33W
 JACKSON COUNTY, MISSOURI

 CIVIL ENGINEERING AND ARCHITECTURAL SERVICES 101 E. 11th St., Suite 400 Overland Park, Kansas 66210 P. (913) 653-1900 WE are members of Hensel Phelps Construction Company, P.A.	Prepared For: SWOPE HEALTH 3801 DR. MARTIN LUTHER KING JR. BLVD KANSAS CITY, MO 64130 816-923-5800
	Design: MGG Drawn: LAS Checked: MGG Issue Date: 05/28/2024 Project Number: 039350
PRELIMINARY PLAT	
C2.0	

Jun 24, 2024 3:37pm Plotted By: matt.gibbs V:\039350-swope_village_campus\04-DWG\Eng\Sheet\PPA\039350-SWITS-SITE-PPA.dwg Layout: C2.0 PRELIMINARY PLAT

SWOPE HEALTH VILLAGE DESIGN STANDARDS

SEE SWOPE VILLAGE CAMPUS BUILDING INFO 2024-05-28 DOCUMENT ON KCMO COMPASS #CD-CPC-2024-00072

WELLNESS PLAZA: A Central Heart for the Village

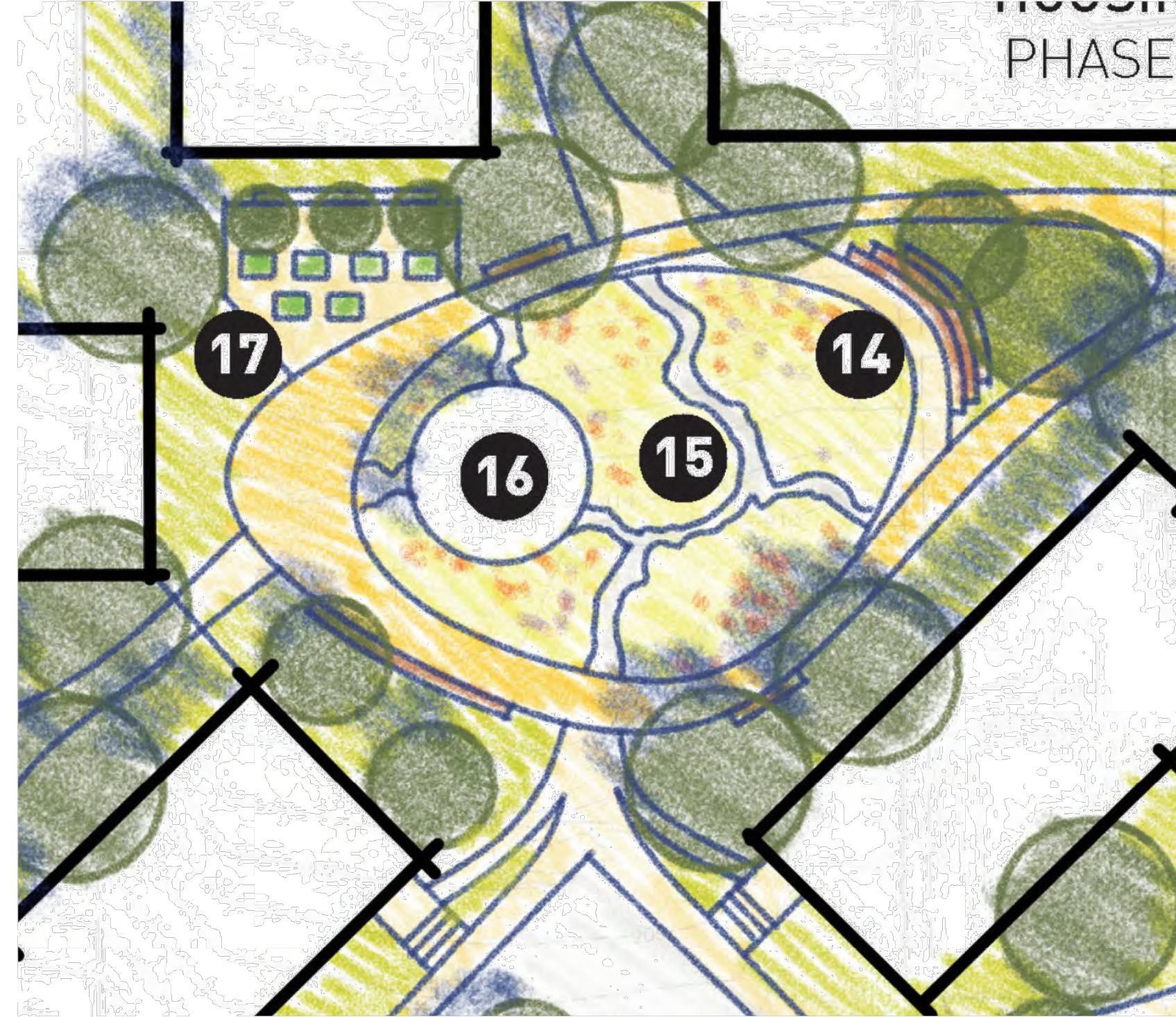

For program, we see community gardens, classes, workout spaces, and a place to relax and enjoy the landscape, a hallmark trait of the site's history.

Cascading from the height in elevation, the space is semi-private and enveloped by the surrounding program. It will be an asset for the Senior Living and Behavioral Health alike.

PERKINS EASTMAN HFG MCLV



A MASTER PLAN FOR SWOPE HEALTH VILLAGE

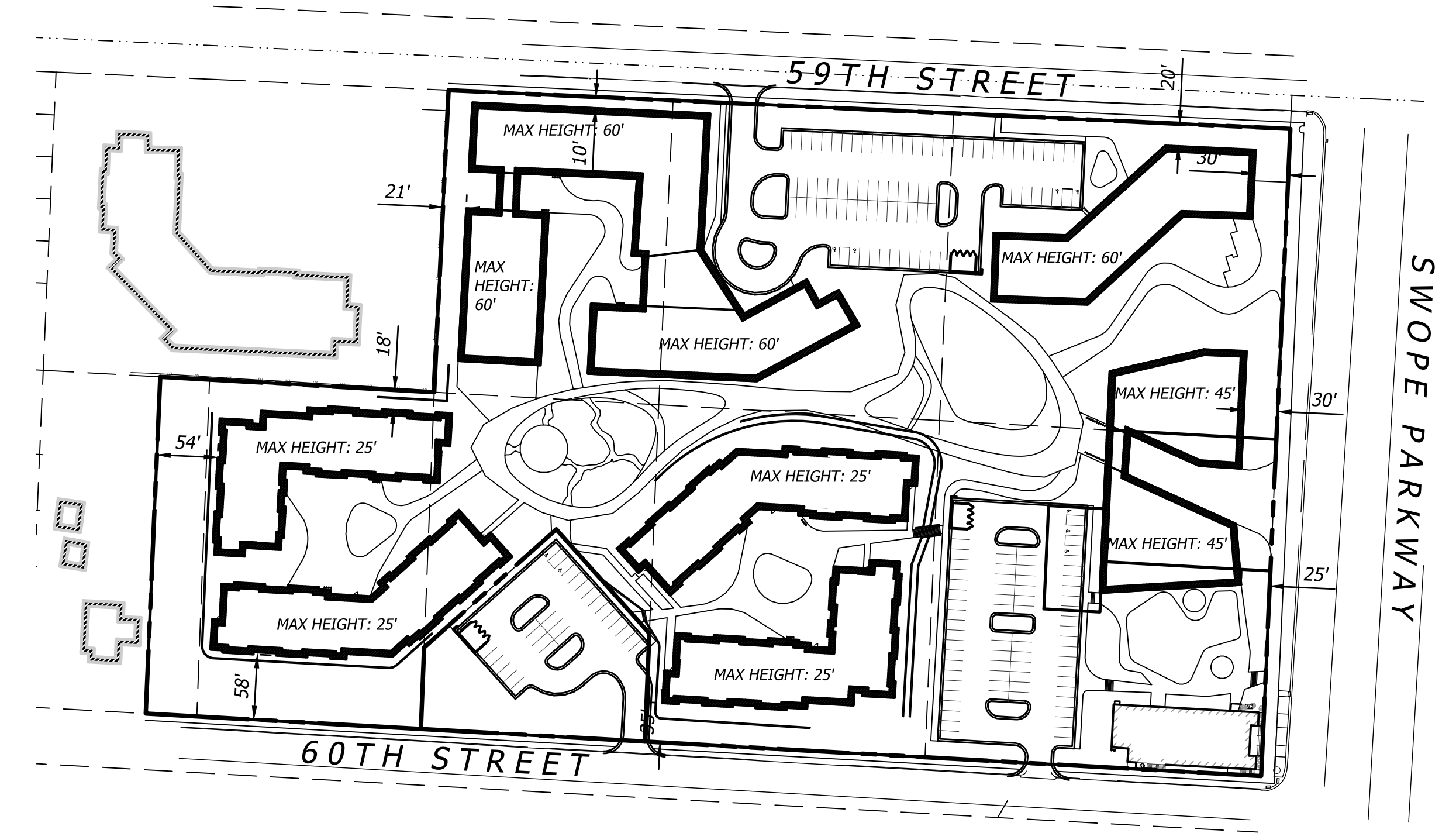

PROPOSED SETBACKS

MAX HEIGHT: 25'



PERKINS EASTMAN HFG MCLV



A MASTER PLAN FOR SWOPE HEALTH VILLAGE

PROPOSED PERSPECTIVE OF OVERALL SITE

Base Material Palette

- Required Materials and Consistency

The exterior materials outlined here will reinforce the overall Architectural Character of the Swope Health Village. Additionally, the approach through these materials will support a project that is forward-thinking while stitching the project meaningfully into the existing character of the Town Fork Creek neighborhood.

In order to maintain a consistent palette and character for Swope Health Village, certain materials are defined with intention to be used at minimum as an accent on the exterior walls of each building in the quantity outlined below.

Community Edge - 80/20 Masonry
Senior Living 70/30 Masonry
Behavioral Health 60/40 Masonry



Masonry

- Required throughout the development to maintain consistency.
- Native material to the Town Fork Creek neighborhood.



Stone

- Intended for base elements of the architecture and landscape.
- Encourage native materials to the region.

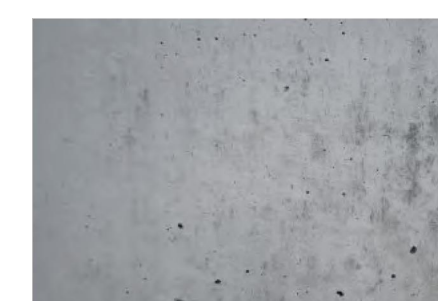

Concrete

- Intended for base elements of the architecture and the landscape.

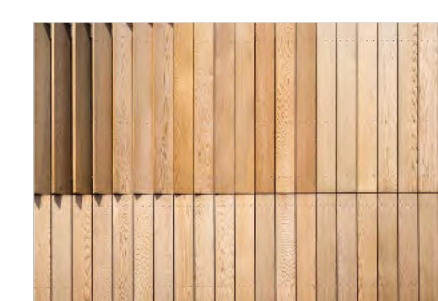

Wood

- Grounds the development in the landscape and tree canopy.
- Intended to provide warmth in detail.

PERKINS EASTMAN HFG MCLV



A MASTER PLAN FOR SWOPE HEALTH VILLAGE

Rev.	Date	Description	By	App.



Prepared For:
SWOPE HEALTH
3801 DR. MARTIN LUTHER KING JR. BLVD
KANSAS CITY, MO 64130
816-923-5800

SWOPE VILLAGE CAMPUS
5900 SWOPE PARKWAY
KANSAS CITY, MO, 64613
DESIGN STANDARDS

Design: MGG | Drawn: LAS
Checked: MGG
Issue Date: 05/28/2024
Project Number: 039350

C3.0

Jun 24, 2024 3:18pm Plotted By: matt.gibbs V:\039350-swope_village Campus (04-DWG) (Eng) Sheet (PDP) 039350-SWTS-GRAD-POP.dwg Layout: C4.0 OVERALL GRADING PLAN

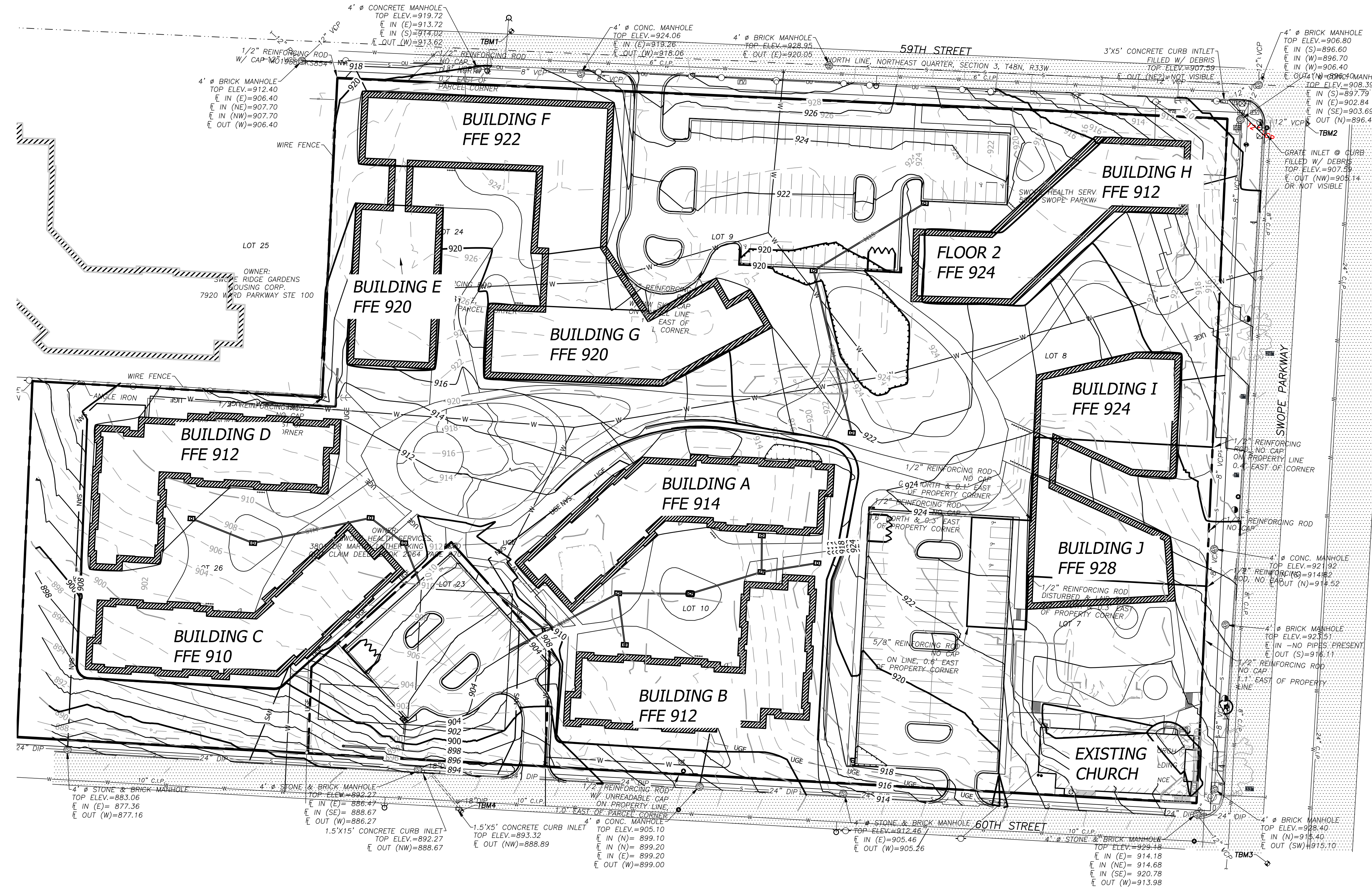

FLOOD STATEMENT
The subject property lies within Flood Zone "X" (unshaded) (Areas determined to be outside the 0.2% annual chance floodplain.), as shown on the Jackson County, Missouri and Incorporated Areas Flood Insurance Rate Map (F.I.R.M.).
Map Number: 29095C0268G Panel No: 268 of 825
Map Revised Date: January 20, 2017
NOTE: This statement is provided for informational purposes only and shall in no way constitute a basis for a flood certificate. No field work was performed to establish the boundaries of this zone. The information was derived by scaling the subject property on the above referenced map.

- BENCHMARKS**
- TBM1 Chiseled "x" cut on SW flange bolt on Fire Hydrant located on N. side of 59th Street across from parking lot entrance. Elevation: 923.26
 - TBM2 Chiseled square cut on center front face of curb inlet located on SE corner of intersection of 59th Street and Swope Parkway. Elevation: 908.30
 - TBM3 Chiseled square cut on center front face of curb inlet located on SE corner of intersection of 60th Street and Swope Parkway. Elevation: 929.12
 - TBM4 Chiseled square cut on SE corner of curb inlet located on South side of 60th Street approximately 640' West of Swope Parkway. Elevation: 893.54

- GRADING LEGEND**
- 980 FINISH GRADE MAJOR CONTOURS
 - 982 FINISH GRADE MINOR CONTOURS
 - 980 EXISTING GRADE MAJOR CONTOURS
 - 982 EXISTING GRADE MINOR CONTOURS
 - PROPERTY LINE
 - R/W RIGHT-OF-WAY LINE

Rev.	Date	Description	By	App.

BHC
Civil Engineering and Surveying Solutions
101 Cliff Brk. Ls. 400
Overland Park, Kansas 66210
p. (913) 653-1900
BHC is a subsidiary of Eough Professional Company, P.A.

Prepared For:
SWOPE HEALTH
3801 DR. MARTIN LUTHER KING JR. BLVD
KANSAS CITY, MO 64130
816-923-5800

SWOPE VILLAGE CAMPUS
5900 SWOPE PARKWAY
KANSAS CITY, MO, 64613
OVERALL GRADING PLAN

Design: MGG | Drawn: LAS
Checked: MGG
Issue Date: 05/28/2024
Project Number: 039350

C4.0

Jun 24, 2024 3:18pm Plotted By: matt.gibbs V:\039350-swope_village Campus\04-DWG\Eng\Sheet\PDF\039350-SPTS-SPTS-UTIL-PPDP.dwg Layout: C4.0 OVERALL UTILITY PLAN

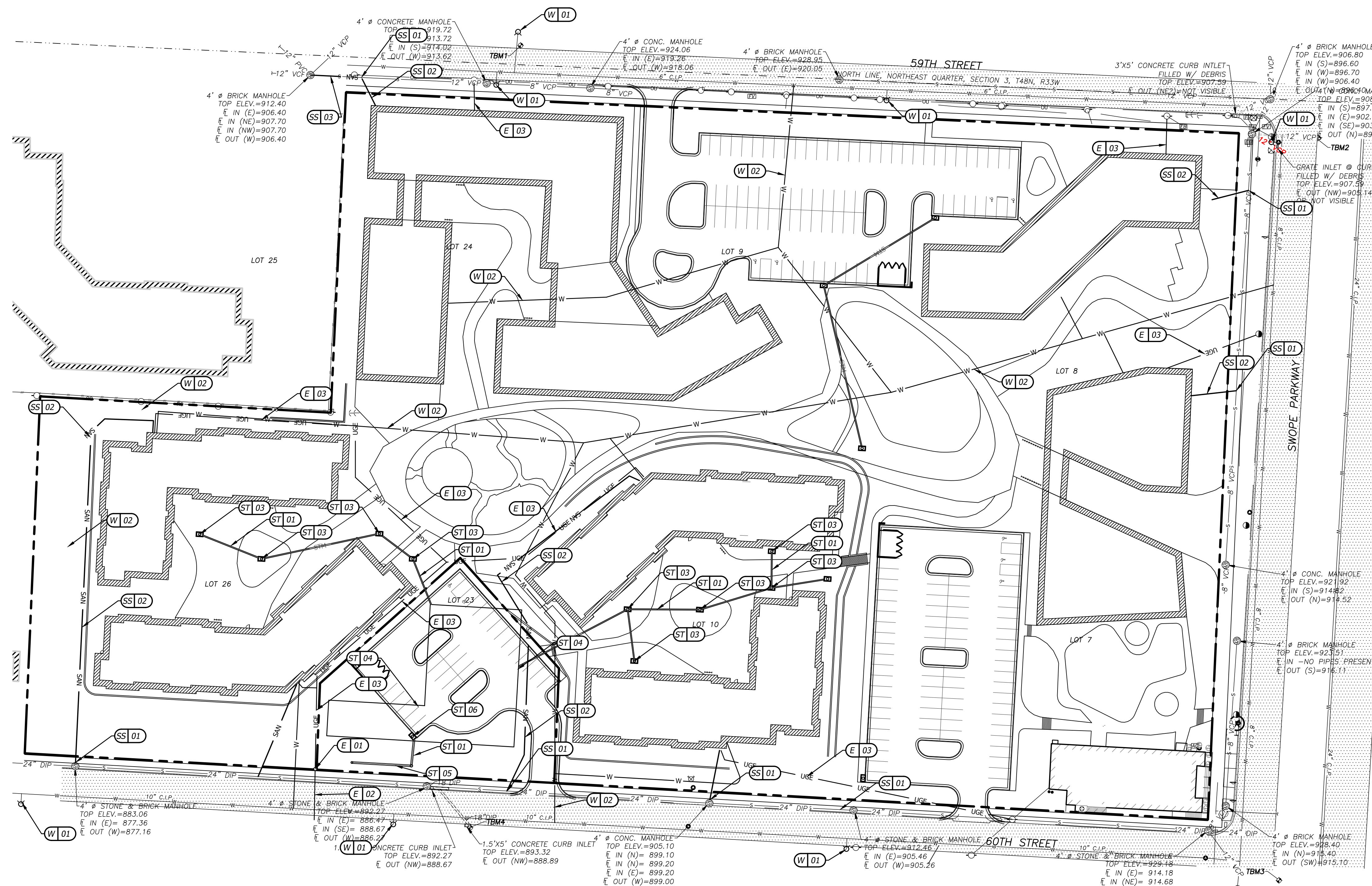

X 00 CONSTRUCTION NOTES

- W - WATER SERVICE INFORMATION - KC WATER
 01 EXISTING FIRE HYDRANT LOCATION
 02 PRIVATE 8" WATER MAIN (FIRE AND DOMESTIC)

- E - ELECTRIC SERVICE INFORMATION - EVERGY
 01 INSTALL POWER POLE
 02 PROPOSED OVERHEAD LINE TO EXISTING POWER LINES
 03 PROPOSED UNDERGROUND LINES FROM POWER POLE

- ST - STORM SEWER INFORMATION - KC WATER
 01 STORM SEWER LINE
 02 STORM SEWER CURB INLET
 03 STORM SEWER AREA INLET
 04 UNDERGROUND DETENTION
 05 PROPOSED LEVEL SPREADER FOR OVERLAND FLOW TO C.S.O.
 06 PROPOSED DETENTION OUTLET CONTROL STRUCTURE

- SS - SANITARY SEWER INFORMATION - KC WATER
 01 CONNECTION AT EXISTING SEWER MAIN
 02 SANITARY SEWER SERVICE LINE
 03 PROPOSED SANITARY MAIN

Design: MGG Drawn: LAS	By	App.
Checked: MGG		
Issue Date: 05/28/2024		
Project Number: 039350		
C5.0		
Swope Village Campus 5900 Swope Parkway Kansas City, MO, 64613 OVERALL UTILITY PLAN		
Prepared For: SWOPE HEALTH 3801 DR. MARTIN LUTHER KING JR. BLVD KANSAS CITY, MO 64130 816-923-5800		
BHC CIVIL ENGINEERING AND SURVEYING CONSULTANTS 101 Call Blvd., Suite 600 Overland Park, Kansas 66210 P. (913) 653-1900 <small>BHC is a member of the Brinkmann Group of Companies, P.A.</small>		

Jun 24, 2024 3:39pm Plotted By: matt.ghibbs V:\039350--swope_village_campus\04-DWG\Eng\Sheet\039350-SITE-PHOTD.dwg Layout: C6.0 PHOTOMETRIC SITE PLAN

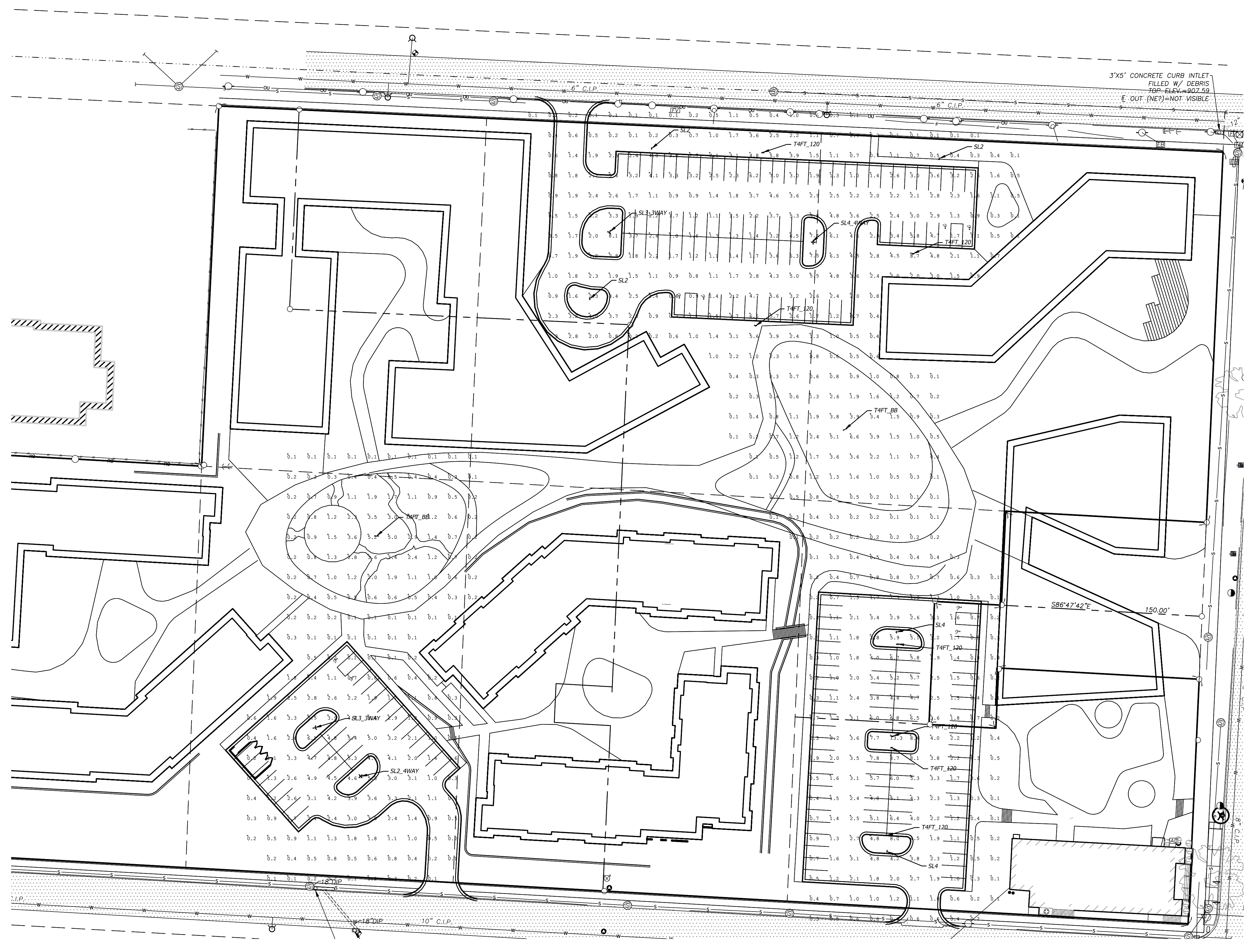

DIMENSION DATA

Number of Light Squares	"A" Width	"B" Standard Arm Length	"B" Optional Arm Length	Weight with Arm (lbs.)	EPA with Arm (Sq. Ft.)
1-4	15'-10" (484mm)	7" (178mm)	10" (254mm)	28 (12.7 kgs)	0.72
5-6	21'-6" (658mm)	7" (178mm)	10" (254mm)	38 (16.3 kgs)	0.77
7-8	27'-5" (838mm)	7" (178mm)	13" (330mm)	43 (19.5 kgs)	0.85
9-10	33'-0" (1007mm)	7" (178mm)	16" (406mm)	49 (22.2 kgs)	1.13

DRILLING PATTERN

TYPE "N"
 3/4" (19mm) Diameter Hole
 1/4" (6mm) Diameter Hole
 7/8" (22mm) Diameter Hole
 1/2" (13mm) Diameter Hole

NOTES: 1. Optional arm length to be used when mounting two fixtures at 90° on a single pole. 2. EPA calculated with optional arm length.

Site Photometric Schedule

Qty	Max	Min	Avg/Min	Max/Min
114	111.7	12.1	114.0	113.20

Fixture Schedule

Symbol	Qty	Label	Arrangement	Description	MF	Mounting Height	Arm
SL2	3	SL2	Single	GLBA-AP-2-180-W1-S12-HSS	0.800	18'	0.583'
SL3	2	SL3	4 # 90 Degrees	GLBA-AP-2-180-W1-S12-HSS	0.800	24.5'	0.583'
SL4	2	SL4	3 # 120 Degrees	GLBA-AP-2-180-W1-S13-HSS	0.800	24.5'	0.583'
T4FT	1	T4FT	Single	GLBA-AP-2-180-W1-S14-HSS	0.800	24.5'	0.583'
T4FT_4WAY	1	T4FT_4WAY	4 # 90 Degrees	GLBA-AP-2-180-W1-S14-HSS	0.800	18'	0.583'
T4FT_120	1	T4FT_120	120 Degrees	GLBA-AP-2-180-W1-T4FT	0.800	18'	0.583'
T4FT_BB	2	T4FT_BB	Back-Back	GLBA-AP-2-180-W1-T4FT	0.800	18'	0.583'

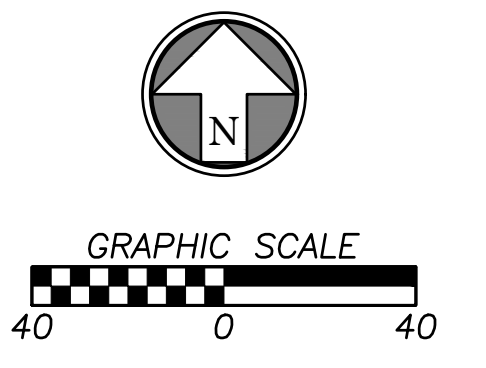

<p>SWOPE VILLAGE CAMPUS 5900 SWOPE PARKWAY KANSAS CITY, MO, 64613</p> <p>PHOTOMETRIC SITE PLAN</p>	<p>Prepared For: SWOPE HEALTH 3801 DR. MARTIN LUTHER KING JR. BLVD KANSAS CITY, MO 64130 816-923-5800</p>
<p>Design: MGG Drawn: LAS Checked: MGG Issue Date: 05/28/2024 Project Number: 039350</p>	<p>By: _____ Date: _____ Description: _____</p>
<p>C6.0</p>	

Jun 24, 2024 3:39pm Plotted By: matt.gibbs V:\039350-swope_village_compas\04-DWG\Sheet\PDF\039350-SP15-NSC-POP.dwg Layout: Overall

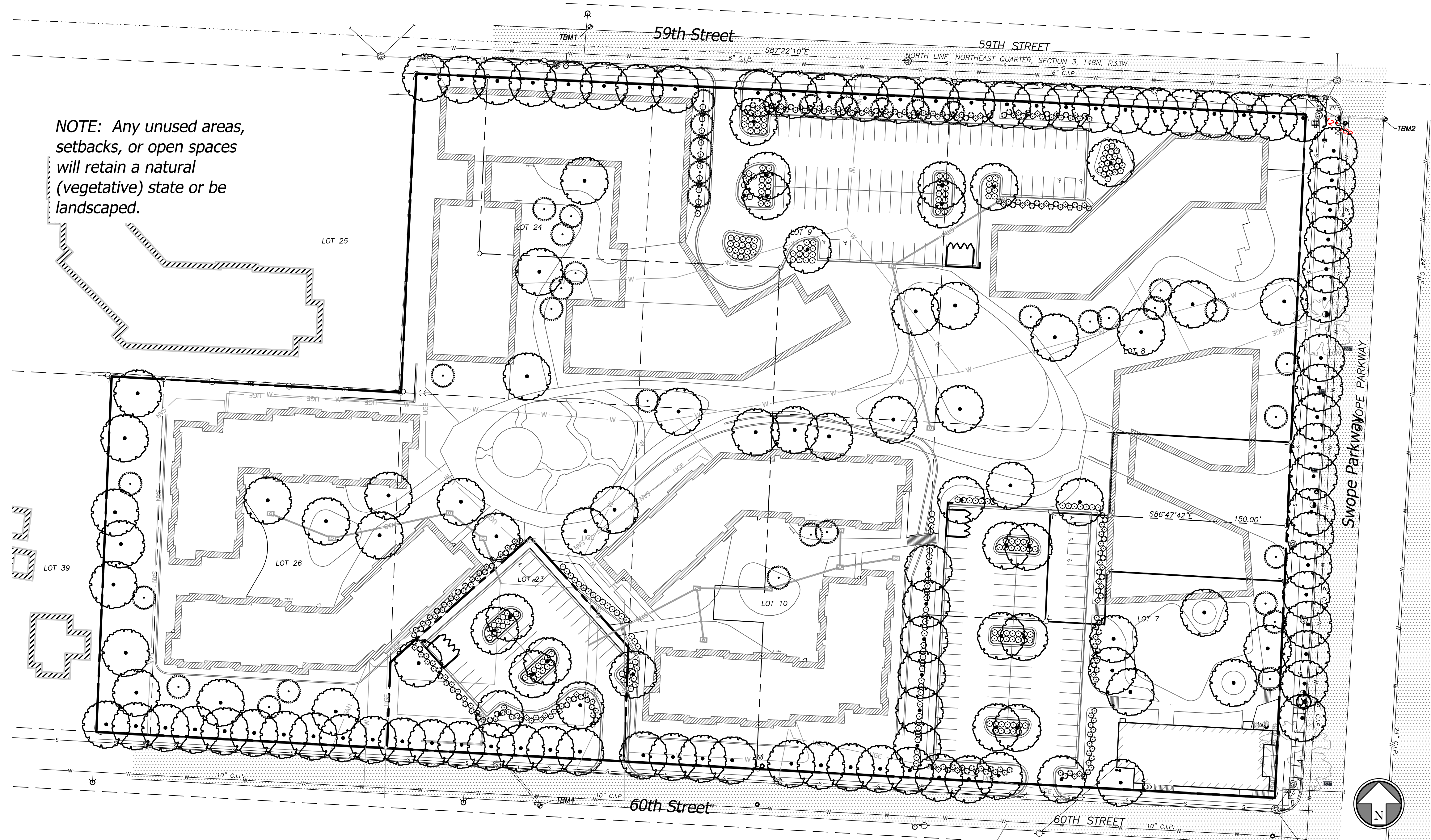

NOTE: Any unused areas, setbacks, or open spaces will retain a natural (vegetative) state or be landscaped.

CONCEPTUAL PLANT SCHEDULE

	LARGE SHADE TREE 2" cal, B&B. Species: Oak, Ginkgo, Hackberry, Linden, Honeylocust	150
	SMALL ORNAMENTAL TREE 2" cal, B&B. Species: Serviceberry, Redbud	39
	EVERGREEN SHRUB 5 gal, min 2' planted height. Species: Juniper, Yew, Holly	246
	MEDIUM SHRUB 5 gal, min 2' planted height. Species: Sweetspire, Oakleaf Hydrangea, Viburnum	268

GENERAL LANDSCAPE NOTES

- The Contractor shall verify and coordinate all final grades with the Landscape Architect and or design team prior to completion.
- Location and placement of all plant material shall be coordinated with the Landscape Architect prior to installation.
- Location of all utilities are approximate, the Contractor shall field verify locations prior to commencement of construction operations.
- Refer to Civil Drawings for all grading and berming, erosion control, storm drainage, utilities and site layout.
- The Contractor shall arrange and conduct a pre-construction meeting onsite with Landscape Architect prior to work.
- Plant quantities are for information only, drawing shall prevail if conflict occurs. Contractor is responsible for calculating own quantities and bid accordingly. Minimum quantities for each category of planting required by City Code must be maintained.
- The Contractor is to notify Landscape Architect after staking is complete and before plant pits are excavated.
- Tree locations in areas adjacent to drives, walks, walls and light fixtures may be field adjusted as approved by Landscape Architect.
- The Contractor shall report subsurface soil or drainage problems to the Landscape Architect.
- The plan is subject to changes based on plant size and material availability. All changes or substitutions must be approved by the City of Kansas City, Missouri and the Landscape Architect.
- Aluminum landscape edging to be used on all landscape beds adjoining turf areas as noted on landscape plans. Edging shall not be used between pavement and landscape beds.
- Landscape Contractor shall be responsible for watering all plant material until the time that a permanent water source is ready.
- The Contractor shall provide a submittal to show proof of procurement, sources, quantities, and varieties for all shrubs, perennials, ornamental grasses, and annuals within 21 days following the award of the contract.
- Contractor shall provide full maintenance for newly landscaped areas for a period of 30 days after the date of final acceptance. At the end of the maintenance period, a healthy, well-rooted, even-colored, viable turf and landscaped area must be established. The landscaped areas shall be free of weeds, open joints, bare areas, and surface irregularities.

SITE DATA

	Quantity	Required	Existing	Provided	Total
Street Tree					
1 tree / 30LF of street					
59th Street	756.7	25.2	N/A	26	26
Swope Parkway	605.3	20.2	2	19	21
60th Street*	966.3	32.2	N/A	31	31
*provided quantity accommodates existing utilities and St. Louis Catholic Church exterior elements					
General Landscaping Trees					
1 tree / 5,000SF of bldg footprint	144075.6	28.8	N/A	98	98
Vehicular Adjacent to Streets					
min 10' wide		Y		Y	
min 1 tree / 30LF (street trees acceptable towards count)	345	11.5	N/A	13	13
continuous 3ft evergreen shrubs		Y		Y	
Island/Interior Landscape (SF)					
parking provided	189				
35SF interior area / parking space	6,615				
1 tree / 5 parking spaces	37.8	N/A	40	40	40
1 shrub / parking space	189	N/A	189	189	189
groundcover on all interior areas		Y		Y	
Landscaping Material					
25+ trees required, no more than 25% of single species		Y		Y	
25+ shrubs required, no more than 75% of single species		Y		Y	
Utility Screening					
above ground cabinets screened		Y		Y	

LEGEND

	PROPOSED STORM SEWER LINE
	PROPOSED ROOF LINE DRAIN
	PROPERTY LINE
	RIGHT-OF-WAY LINE
	TREE PROTECTION

<p>BHC Civil Engineering, Architecture, Interiors 101 Call Blvd., Ste. 400 Overland Park, Kansas 66210 p. 913.653.1900 We're a member of the HOK Group</p>		<p>Prepared For: SWOPE HEALTH 3801 DR. MARTIN LUTHER KING JR. BLVD KANSAS CITY, MO 64130 816-923-5800</p>
<p>SWOPE VILLAGE CAMPUS 5900 SWOPE PARKWAY KANSAS CITY, MO, 64613</p>		<p>OVERALL LANDSCAPE PLAN</p>
<p>Design: ADM Drawn: ADM Checked: MG Issue Date: 05/28/2024 Project Number: 039350</p>	<p>By</p>	<p>App.</p>
<p>L1.0</p>		<p>Rev.</p>
<p>Date</p>		<p>Description</p>

Jul 29, 2024 - 5:11pm Plotted By: lance.abold V:\039350-Swope Village Campus\04-DWG\Eng\Sheet\039350-SHVS-PHOTO.dwg Layout: C5.0 PHOTOMETRIC SITE PLAN

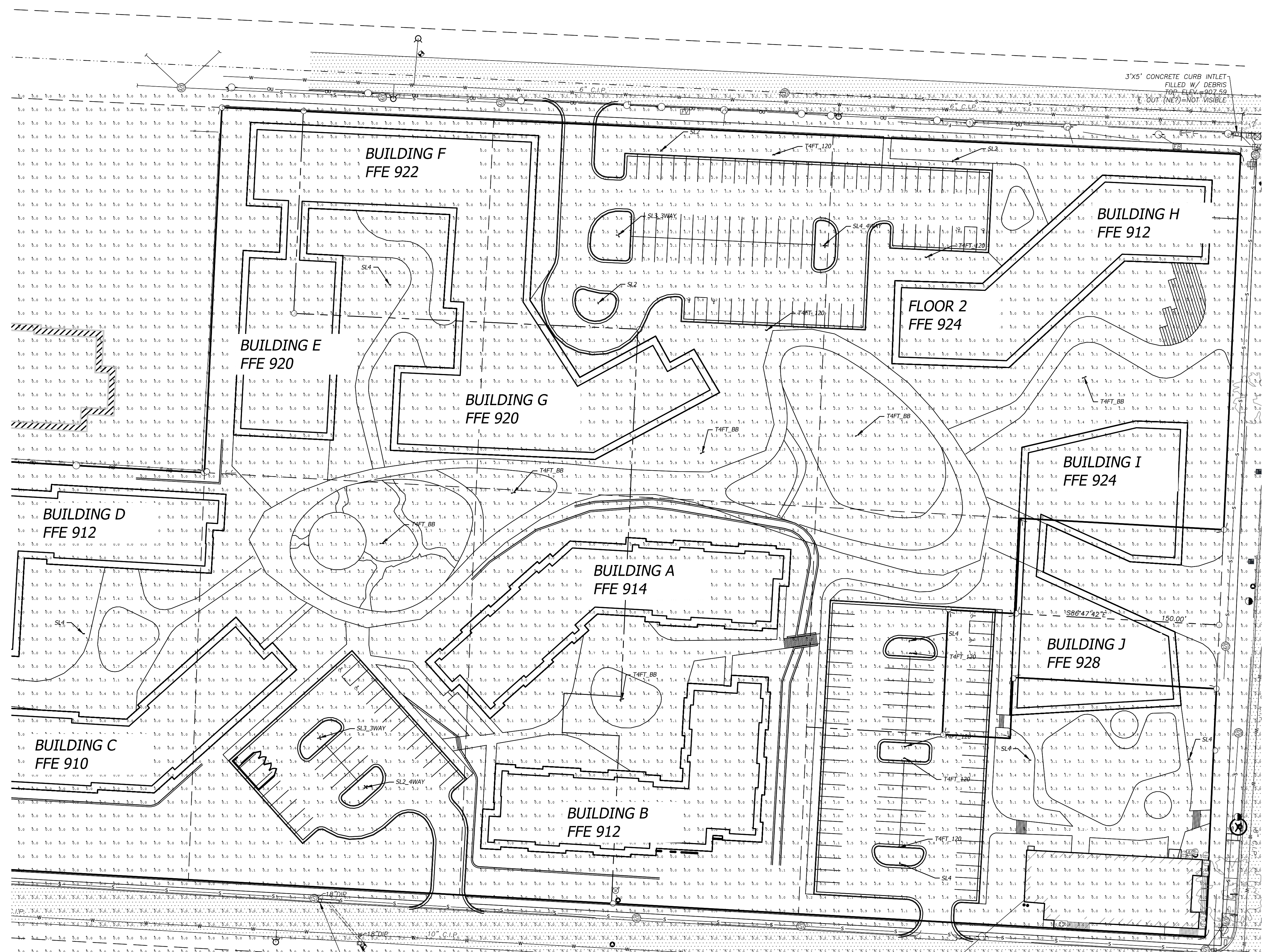

DIMENSION DATA

Number of Light Spheres	"A" Width (294mm)	"B" Standard Arm Length (178mm)	"B" Optional Arm Length (254mm)	Weight with Arm (lbs.) (12.7 kgs)	EPA with Arm (Sq. Ft.)
1-4	15-1/2"	7"	10"	28	0.72
5-6	21-5/8"	7"	10"	38	0.77
7-8	27-5/8"	7"	13"	43	0.85
9-10	23-3/4"	7"	10"	49	1.13

NOTES: 1. Optional arm length to be used when mounting two fixtures at 90° on a single pole. 2. EPA calculated with optional arm length.

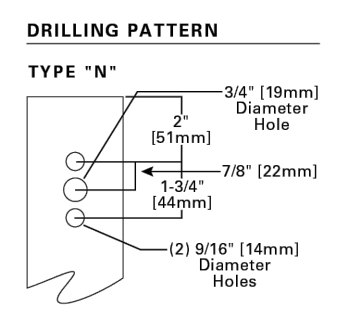

Site Photometric Schedule

Symbol	Avg	Max	Min	Avg/Min	Max/Min
1	0.23	111.1	19.9	14.4	5.6

Luminaire Schedule

Symbol	Qty	Label	Arrangement	Description	MF	Mounting Height	Arm
1	3	S12	Single	GR8A-AP-02-180-W1-S12-HSS	0.800	18'	0.583
2	1	S13 way	4 @ 90 Degrees	GR8A-AP-02-180-W1-S13-HSS	0.800	24.5'	0.583
3	2	S13 way	3 @ 120 Degrees	GR8A-AP-02-180-W1-S13-HSS	0.800	24.5'	0.583
4	1	S14	Single	GR8A-AP-02-180-W1-S14-HSS	0.800	18'	0.583
5	1	S14 way	4 @ 90 Degrees	GR8A-AP-02-180-W1-S14-HSS	0.800	18'	0.583
6	1	TAPP 120	120 Degrees	GR8A-AP-02-180-W1-TAPP	0.800	18'	0
7	1	TAPP BB	Back-Back	GR8A-AP-02-180-W1-TAPP	0.800	18'	0.583

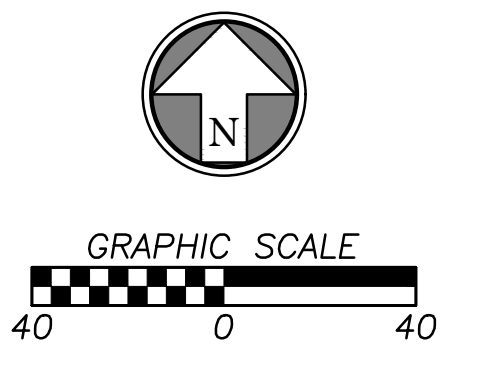

By	App.	Date	Rev.	Description

BHC
BRIGHT HEALTH CARE
101 Call Blvd., Suite 400
Overland Park, Kansas 66210
p. 913.653.1900
BHC is a member of Bright Health System, P.A.

Prepared For:
SWOPE HEALTH
3801 DR. MARTIN LUTHER
KING JR. BLVD
KANSAS CITY, MO 64130
816-923-5800

SWOPE VILLAGE CAMPUS
5900 SWOPE PARKWAY
KANSAS CITY, MO, 64613

PHOTOMETRIC SITE PLAN

Design: MGG	Drawn: LAS
Checked: MGG	Issue Date: 05/28/2024
Project Number: 039350	

C6.0

Jul 29, 2024 - 6:27pm Plotted By: angela.mayer V:\039350-Swope Village Campus\04-DWG\Enr\Sheet\DDP\039350-SRTS-LNSC-PPP.dwg Layout: TreeMit



TREE MITIGATION SITE DATA

Tree Mitigation Requirement	Quantity	Total
Total acreage of canopy cover to be removed	2.96	2.96
Subtract undisturbed acres of stream buffer	N/A	2.96
Multiply acreage by 0.35	0.35	1.036
Multiply acreage by 150 caliper inches	150	155.4
Subtract total caliper inches of trees provided for required landscaping	368	-212.6
Total required caliper inches required for mitigation: <i>(Proposed plan exceeds requirement)</i>		-212.6

LEGEND

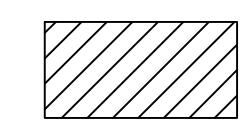

TREE CANOPY COVERAGE TO BE REMOVED
(All existing trees on site to be removed due to proposed development and proposed grades.)

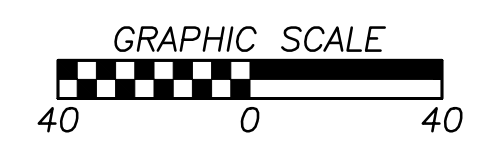

<p>SWOPE VILLAGE CAMPUS 5900 SWOPE PARKWAY KANSAS CITY, MO, 64613</p> <p>TREE CANOPY COVERAGE AND MITIGATION</p>	<p>Design: ADM Drawn: ADM Checked: WB Issue Date: 07/30/2024 Project Number: 039350</p>										
<p>Prepared For:</p> <p>SWOPE HEALTH 3801 DR. MARTIN LUTHER KING JR. BLVD KANSAS CITY, MO 64130 816-923-5800</p>											
 <p>BHC CIVIL ENGINEERS AND ARCHITECTS 101 Ellis Blvd., Suite 400 Overland Park, Kansas 66210 p. 913.653.1900 BHC is a member of Hensel Phelps Construction Company, P.A.</p>											
	<table border="1" style="width: 100%; border-collapse: collapse;"> <tr> <th>Rev.</th> <th>Date</th> <th>Description</th> <th>By</th> <th>App.</th> </tr> <tr> <td> </td> <td> </td> <td> </td> <td> </td> <td> </td> </tr> </table>	Rev.	Date	Description	By	App.					
Rev.	Date	Description	By	App.							

“Restoring the quality of life of our residents by providing holistic health care services in a nurturing, understanding environment. We want to do more than minimize suffering, we seek to create well-being for each member of the under-served urban core..”

SITE ATTRIBUTES

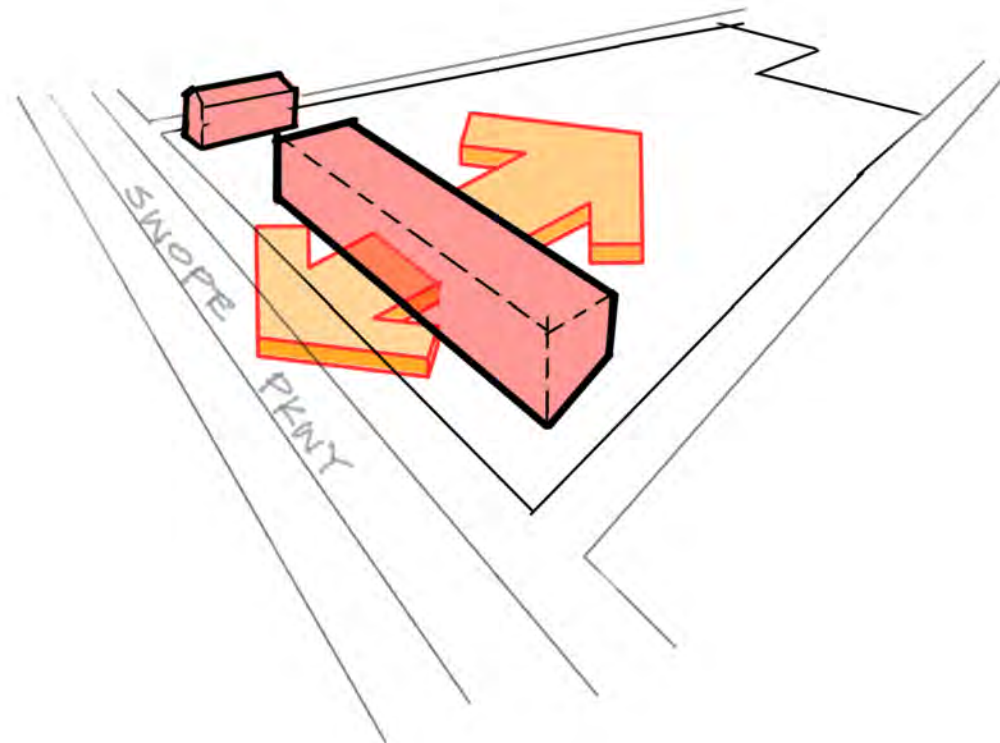

Stitching the Community

Here, we emphasize the Swope Parkway edge as an opportunity to create a meaningful Swope and community partnership edge. Address through action and compassion.

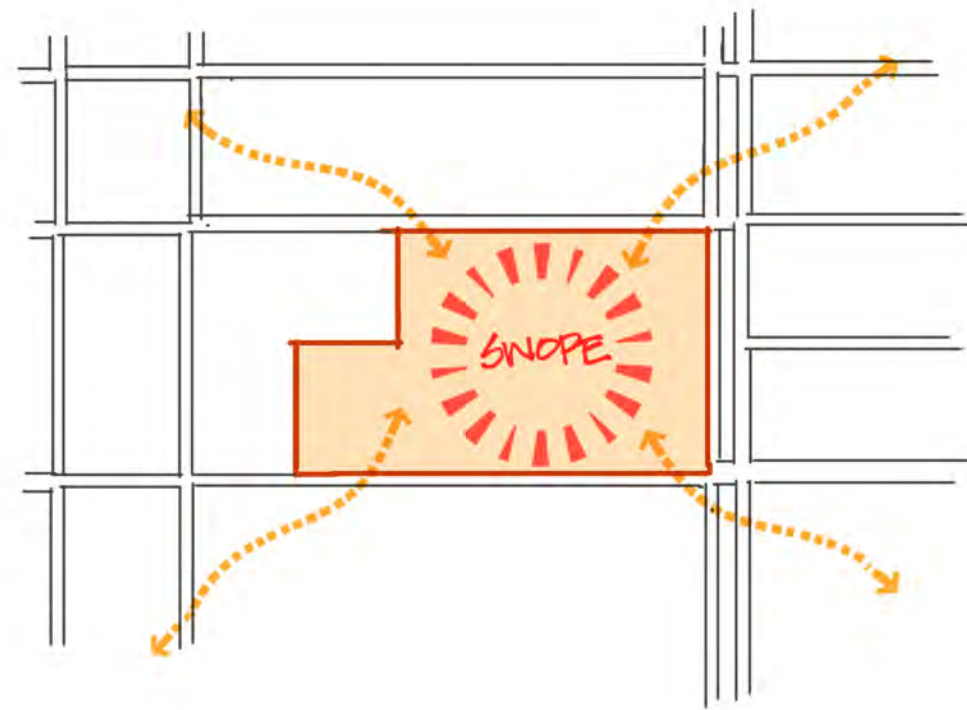

The Quad as the Heart of Community

Within the neighborhood, down to the block itself, the core of the Swope Health Village is to foster community through civic, landscaped spaces.

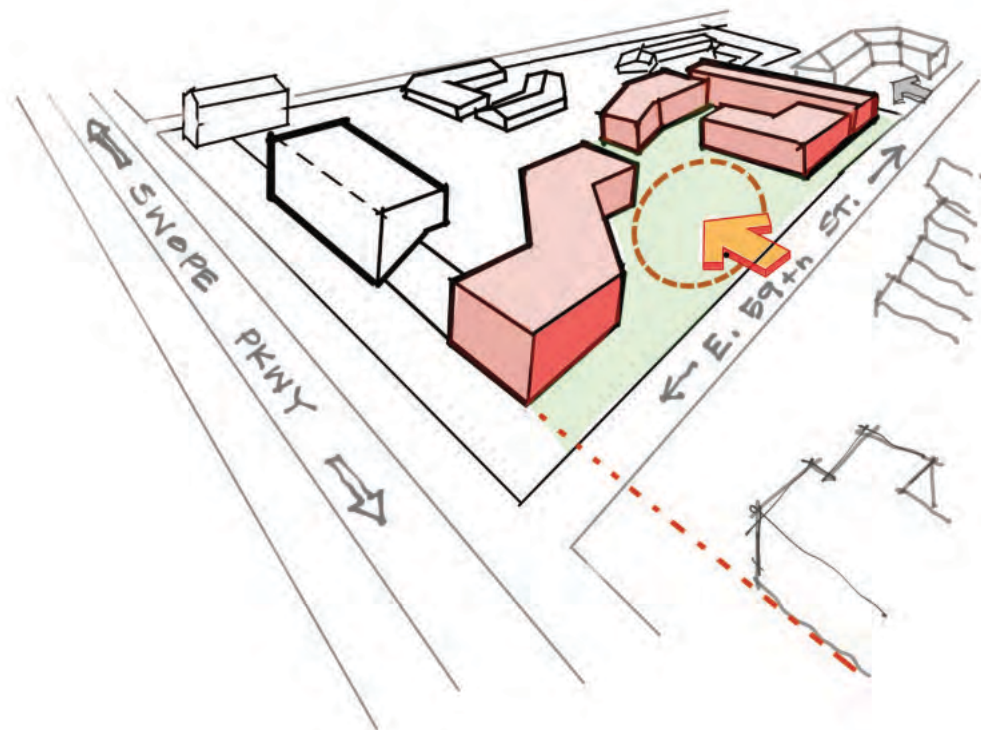

Senior Living as Neighborhood Living

Within a community passionate about Home, the senior living program is positioned as another step to live in and embrace the experience of the broader community.

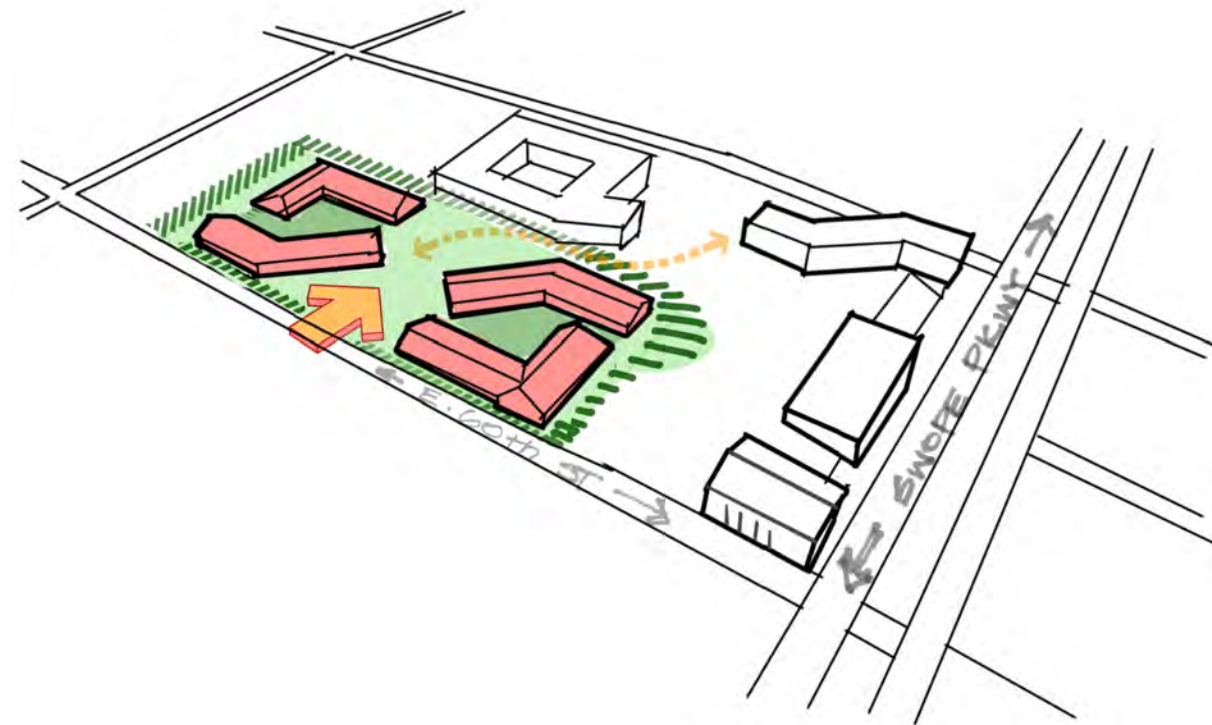

Behavioral Health set in a Tranquil, Celebrated Setting

Informed by the topography and meaning of the tree grove, the Behavioral Health program is embraced and protected for healing and growth.

SITE: Proposed Plan

- | | | | |
|----|---------------------------|----|----------------------------|
| 1 | 59th St Plaza Entrance | 11 | Water Feature |
| 2 | Mid-Block Promenade | 12 | N. Parking (~80 stalls) |
| 3 | Playground | 13 | Walking Loop |
| 4 | Therapy Terrace | 14 | Amphitheater |
| 5 | Sport Court | 15 | Prairie Garden |
| 6 | S.E. Parking (~60 stalls) | 16 | Garden House |
| 7 | Central Plaza | 17 | Orchard / Vegetable Garden |
| 8 | Activity Lawn | 18 | Interior Courtyard |
| 9 | Pavilion / Gazebo | 19 | S.W. Parking (~35 stalls) |
| 10 | Terrace Plaza | 20 | Woodland Garden |

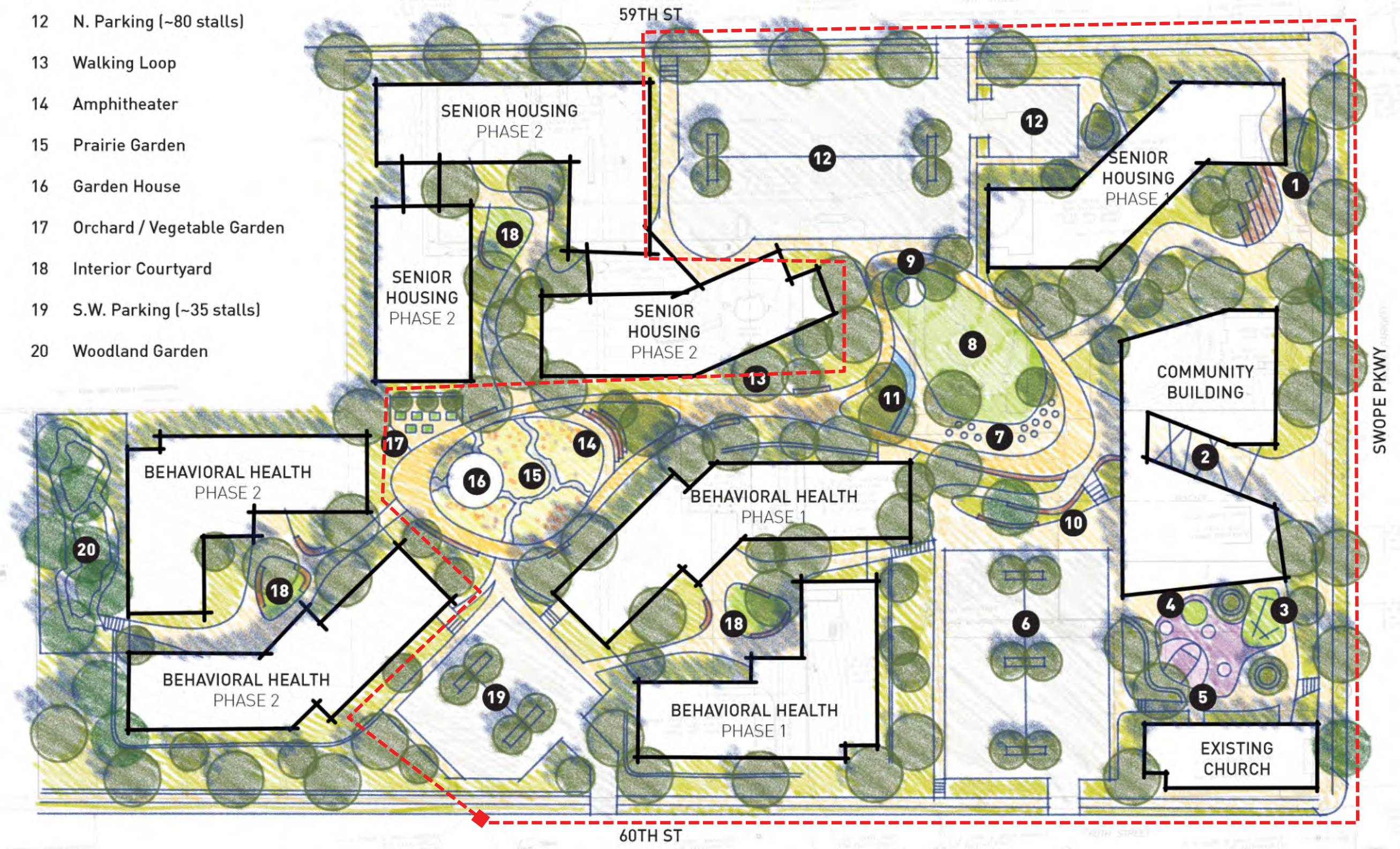



swopeHEALTH

swopeHEALTH

swopeHEALTH

A MASTER PLAN FOR SWOPE HEALTH VILLAGE

PERKINS EASTMAN HFG architecture MCLV

swopeHEALTH

SWOPE PRESENCE: Stitching Community Edges



The edge is welcoming and activated, with defining moments of access and connection. These areas, in turn, will be secure through having eye on the pathways.



Diversity of program will be the most important consideration. As our research around jobs suggests as one example, we want to create opportunity and access for all.

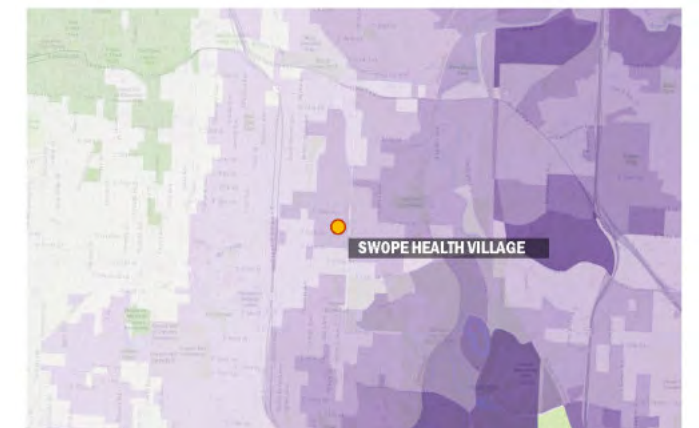

SWOPE PRESENCE: Stitching Community Edges

The community building is an ever-present backdrop that will represent the core of Swope's commitment to the community.

Though iconic, the entries are also scaled. There is an opportunity for the landscape and ground to blend with the way people will enjoy the space.

SWOPE PRESENCE: Stitching Community Edges



Our approach to the multi-purpose building is to cultivate meaningful relationships between Swope and its community partners through inspiring design and presence.

The library will be a simple adaptive reuse to honor the structure and introduce a community driven program.



An interesting aspect of Kansas City's architecture is in the details, where historical styles question the setting and prompt a new way of thinking of place. We aim to create a language rooted in the neighborhood that can also be something different, akin to many celebrated places from the past.



SITE APPROACH: Open Spaces

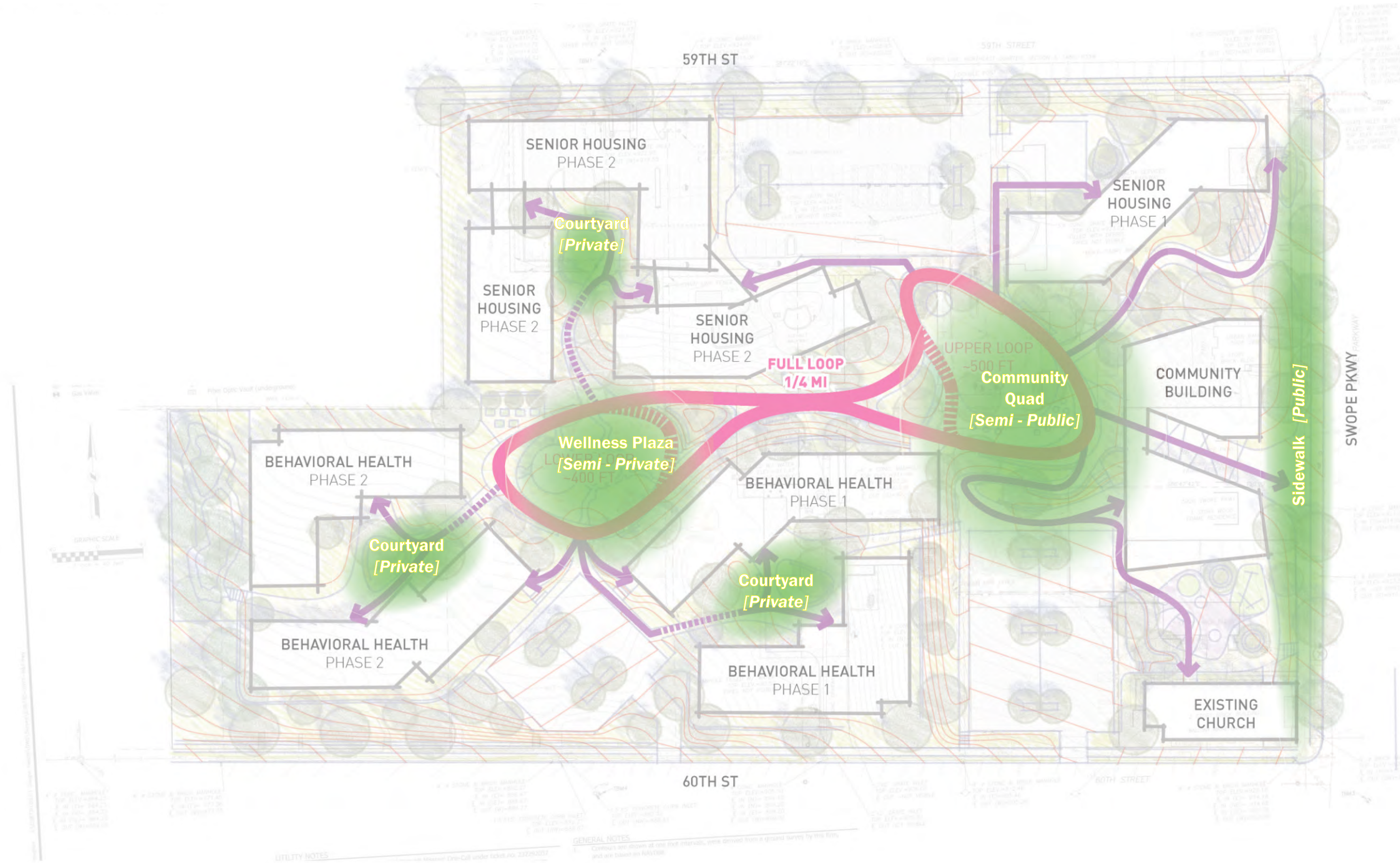

LANDSCAPE DESIGN: Planting Character

Planting Character

The planting character outlined here is reminiscent of the native landscape found in Swope Park and the Kansas-City region, which includes a mix of deciduous and coniferous trees, shrubs, grasses, herbaceous perennials, and groundcovers. The planting design will use swaths of planting mixes for ease of maintenance and visual clarity. Selected plants will emphasize warm-tones, seasonal change, and sensory interest such as textural bark or short grasses that make noise in the wind.

Trees & Shrubs

- Native trees with high ecological value such as species in the Quercus, Salix, and Prunus genera
- Provide shade without encumbering sightlines
- Prioritize preservation of mature existing trees

Understory

- Prioritize species that attract butterflies, birds, and nesting habitat for wildlife
- Locate plants where resident interaction is encouraged
- Minimize complexity of species mixes for ease of maintenance
- Select shorter species to maintain campus sightlines
- Promote water and air quality through the use of BMP's
- Orchard and vegetable garden will provide direct access to food for residents



Native planting design character with clear sightlines and warm tones.

Planting design swaths for maintenance feasibility.



Planting design that conveys openness and uses trees to define space.



June 13, 2024

To surrounding neighbors,

A proposed project located on several lots between the intersections of 59th and Swope and 60th and Swope. The exact addresses are 3427 E 59th Street, 5900, 5924, 5926, and 5930 Swope Parkway. This project requires a public engagement meeting. The property will be replatted into four lots as part of the project. The project requires rezoning of area from R1.5 to MPD to allow for the construction of behavioral health buildings, senior housing and a community center.

We have enclosed the preliminary development plan which includes the preliminary site layout, preliminary building renderings, preliminary plat, preliminary landscape plan, and preliminary grading plan. The purpose of the meeting will be to discuss any concerns about the overall project.

A public engagement meeting will be held in person at the:

Southeast Community Center
3400 E 63rd St, Kansas City, MO 64130
on
June 26th, 2024, at 6:00 pm.

Sincerely,

A handwritten signature in blue ink that reads 'Matthew Gibbs'.

Matthew Gibbs, PE
Senior Project Engineer
BHC
7101 College Blvd, Suite 400
Overland Park, KS 66210



913.663.1900



ibhc.com



7101 College Blvd., Ste. 400



Swope Village Campus MPD and Area Plan Neighborhood Meeting Summary

June 26th, 2024, 6:00 PM to 7:00 PM, Southeast Community Center

Attendees: Matthew Gibbs (BHC); Bret Gross (Copaken Brooks), Larry Crane (HFG Architecture), Jeron Ravin (Swope Health), Mark Miller (Swope Health), Josette Mitchell (Swope Health)

Neighbors: Sherrita Richardson (3413 E 60th Street), Harvey Hubert (3417 E 60th Street), Jesse and Shirley Frazier (3416 E 60th Street), David Zachery (3614 E 59th Street), Covenant Presbyterian Church KC – Marlene Reed (5931 Swope Parkway – 4635 Chelsea Ave)

Meeting started at 6:00 p.m.

The master planned development was talked about at length by Mr. Ravin. The conversation shifted to the overall development of the proposed Swope Village Campus development and how it impacts the area. The neighbors were concerned about the safety, lighting, security and stormwater runoff of the project. Swope has private security that revolves around their sites. The site will be well lit in the parking lots and moderately lit along the paths chosen by the design team at a future date. The site will also be monitored by the residents themselves as there will be activities for the residents and public going on during the days. The stormwater will be managed via underground detention system(s) along the south side of the site. The neighbors were agreeable to the project and wanted to know the approximate project timeline. Mr. Ravin stated the approximate timeline for the project completion was in 2029. The meeting then wrapped up and adjourned.

Meeting adjourned at 7:00 p.m.

If you have further questions about anything that was discussed at the neighborhood meeting, please contact me at matt.gibbs@ibhc.com or 913-663-1900.

Respectfully,

Matthew Gibbs, PE
Senior Project Engineer
BHC
7101 College Blvd, Suite 400
Overland Park, KS 66210