



- Executed Contract File
- Contractor
- Finance
- City Clerk
- Surety
- Granting Agency
- Project Manager
- CM/Inspector
- Design Professional
- _____

**City of Kansas City, Missouri
Water Services Department
Kenneth Morgan P.E., Director**

Project Manual

FOR

**PROJECT/CONTRACT NO. 60XX0028/9835-1
WD ASPHALT AND CONCRETE, CITY WIDE
RENEWAL No. 1**

BIDDER/ADDRESS

Company	Superior Bowen Asphalt Co.
Contact	Mathew Bowen
Address	520 W. Pennway, Suite 300 Kansas City, MO. 64108
Phone	816-921-8100
Fax	816-912-3224
Email	matt@superiorbowen.com

Project Manager: Todd Rohr
Telephone: 816-513-0323
Email: todd.rohr@kcmo.org



CERTIFICATION PAGE

Project Number 60XX0028

Project Title WD Asphalt and Concrete

I am responsible for the following specifications and drawings:

Drawings:

None

Specifications:

Division 2:

02202,02250,02575,02608

02618,02641,02930,02931

Division 3:

03000,03001,03100,03200

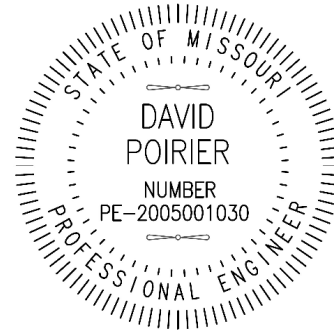

(SEAL)

I am responsible for the following specifications and drawings:

Drawings:

Specifications:

(SEAL)

I am responsible for the following specifications and drawings:

Drawings:

Specifications:

(SEAL)

EACH PROFESSIONAL WHOSE SIGNATURE AND PERSONAL SEAL APPEARS ABOVE ASSUMES RESPONSIBILITY IN THESE BIDDING DOCUMENTS ONLY FOR WHAT IS LISTED ABOVE AND DISCLAIMS (PURSUANT TO SECTION 327.411 RSMO) ANY RESPONSIBILITY FOR ALL OTHER PLANS, SPECIFICATIONS, ESTIMATES, REPORTS, OR OTHER DOCUMENTS OR INSTRUMENTS NOT SEALED BY THE SIGNED PROFESSIONAL RELATING TO OR INTENDED TO BE USED FOR ANY PART OR PARTS OF THE PROJECT.



BID FORM/CONTRACT

Project /Contract Numbers: 608XX0028/9835-1

Project Title: WD Asphalt and Concrete, City Wide

1. Bidder, having examined the Bidding Documents, related documents and the Site of the Work, and being familiar with all the conditions affecting the construction of the proposed Work, including Laws and Regulations and the availability of materials and supplies, agrees, if this Bid is selected by CITY, this Bid Form/Contract will become the Contract between Bidder and CITY for Bidder to furnish all labor and materials, equipment and services necessary for the proper completion of the Work in accordance with the Contract Documents, including general construction work at the price(s) stated below, which stated sums include fees and all other charges applicable to materials, appliances, labor and all things subject to and upon which other charges may be levied.
2. Bidder agrees the Contract Documents will comprise the entire agreement between CITY and Bidder. The Contract Documents are identified in the General Conditions and are incorporated into and made part hereof this Bid Form/Contract by reference.
3. Bidder agrees that if this Bid Form/Contract is executed by CITY, Bidder's offer is accepted and this Bid Form/Contract that incorporates all other Contract Documents shall constitute the Contract between the parties. Bidder authorizes the CITY to fill in the Contract Price on this Bid Form/Contract in accordance with Bidder's Bid. Bidder agrees that this Bid Form/Contract may be executed in one or more counterparts, each of which will be deemed an original copy of this Bid Form/Contract and all of which, when taken together, will be deemed to constitute one and the same Bid Form/Contract. This Bid Form/Contract shall be effective upon the execution of counterparts by both parties, notwithstanding that both parties may not sign the same counterpart. The parties' signatures transmitted by facsimile or by other electronic means shall be proof of the execution of this Bid Form/Contract and shall be acceptable in a court of law. A copy of this Bid Form/Contract shall constitute an original and shall be acceptable in a court of law.
4. The maximum obligation of the CITY for the Work is \$7,500,000.00, including Unit Prices. The sum of the extensions of the Unit Prices form is \$ _____, and shall be considered in determining the lowest and best bid. The actual number of units worked and paid for under this Contract may be more or less than the estimated quantity given or may be none.
5. The bidder agrees that this is the final renewal to this Contract if so requested by the CITY. The determination to renew the Contract will be at the sole discretion of the CITY where such renewal would be in the best interest of the CITY and subjected to the availability and appropriation of funds. An increase in a unit price, if any, will be determined solely by the CITY, and if needed, will not exceed the change in the Consumer Price Index for the period since the Contract was signed.
6. The undersigned Bidder has given CITY'S Project Manager written notice of all conflicts, errors or discrepancies that it has discovered in the Contract Documents and the written resolution thereof by the Project Manager or by the DESIGN PROFESSIONAL is acceptable to Bidder.
7. The undersigned Bidder agrees that this Bid shall remain subject to selection by CITY, and may not be withdrawn for ninety (90) days after the day Bids are opened.
8. The undersigned Bidder certifies that this Bid contains no modifications, deviations, riders or qualifications.
9. Form(s) 00412 Unit Prices, contain prices included in the Base Bid, and are incorporated into this Bid. Form(s) must be completed and returned with this Bid.

- a. The Contract Price will be subject to adjustment according to final measured, used, or delivered quantities, and the adjustment unit prices in the Bid will apply to such final quantities

10. The undersigned Bidder acknowledges receipt of the following addenda listed by number and date appearing on each addendum:

Addendum Number	Dated	Addendum Number	Dated
(N/A_____)	(_____)	(_____)	(_____)
(_____)	(_____)	(_____)	(_____)
(_____)	(_____)	(_____)	(_____)

11. By submitting its bid, Bidder is agreeing to meet or exceed the minimum employment goals of 10% minority and 2% women during the term of its contract with the City, or request a waiver of the goals. If a waiver is requested, Bidder must establish good faith efforts towards meeting the goals as set forth in the CREO-KC Instructions for Construction Contracts and the City’s Workforce Ordinance. Should Bidder fail to meet or exceed the minimum employment goals or otherwise establish that Bidder is entitled to a waiver under circumstances in which Bidder has previously failed to meet or exceed the goals on one or more occasions with the twenty-four month period immediately preceding the completion of the Work under this Bid Form/Contract, Bidder may be suspended from participating, either as a contractor or subcontractor, on any future contract with the City for a period ranging from thirty days to six months as further specified in the Contract Documents.

12. By submitting its bid, Bidder warrants that if its bid should exceed \$300,000.00 and Bidder employs fifty (50) or more people, Bidder has an affirmative action program in place and will maintain the affirmative action program in place for the duration of its contract with the City. Bidder further warrants that it will comply with the affirmative action requirements contained in the General Conditions as incorporated by reference into this Bid Form/Contract.

13. Section 14 through Section 17 constitutes the Affidavit of Intended Utilization required to be submitted by Bidders.

14. By submitting its bid, Bidder is agreeing to the following: (1) Bidder has made by bid opening a good faith effort to meet the MBE/WBE/DBE goals established for the project; or Bidder will continue to make during the 48 hours after bid opening a good faith effort to meet the MBE/WBE/DBE goals established for the project; and (2) Bidder will timely submit its **00450 CREO-KC 08 Contractor Utilization Plan/Request for Waiver** and **00450.01 Letter of Intent to Subcontract** for each MBE/WBE listed on the 00450 CREO-KC 08 Construction Contractor Utilization Plan/Request for Waiver;; and (3) Bidder will submit documentation of its good faith efforts to meet the MBE/WBE/DBE goals when requested by the City. Failure to meet these requirements in good faith will result in Bidder forfeiting its bid bond.

PROJECT GOALS: 6 % MBE 6 % WBE _____ % DBE

BIDDER PARTICIPATION: 6 % MBE 6 % WBE _____ % DBE

15. To the best of Bidder’s knowledge, the following are names of certified MBEs and/or WBEs with whom Bidder, or Bidder’s subcontractors, presently intend to contract with if awarded the Contract on the above project: **(All firms must currently be certified by Kansas City, Missouri Civil Rights and Equal Opportunity Department)**

Bidder: Superior Bowen Asphalt Co.

- A. Name of M/WBE Firm _____
Address _____
Telephone No. _____
I.R.S. No. _____
Area/Scope of work _____
Subcontract amount _____

- B. Name of M/WBE Firm _____
Address _____
Telephone No. _____
I.R.S. No. _____
Area/Scope of work _____
Subcontract amount _____

- C. Name of M/WBE Firm _____
Address _____
Telephone No. _____
I.R.S. No. _____
Area/Scope of work _____
Subcontract amount _____

- D. Name of M/WBE Firm _____
Address _____
Telephone No. _____
I.R.S. No. _____
Area/Scope of work _____
Subcontract amount _____

- E. Name of M/WBE Firm _____
Address _____
Telephone No. _____
I.R.S. No. _____
Area/Scope of work _____
Subcontract amount _____

- F. Name of M/WBE Firm _____
Address _____
Telephone No. _____
I.R.S. No. _____
Area/Scope of work _____
Subcontract amount _____

(List additional MBE/WBEs, if any, on additional pages and attach to this form)

- 16. By submitting its bid, Bidder is agreeing it will identify and timely submit within 48 Hours after Bid opening those MBE/WBE subcontractors with dollar amounts and scopes of work, which apply to or exceed the MBE/WBE goals for the Project on the **00450 CREO-KC 08 Contractor Utilization Plan/Request for Waiver**.

- 17. Bidder agrees that failure to meet or exceed the MBE/WBE Goals for the above project will require the Director of Human Relations to recommend disapproval of the bid unless the Director of Civil Rights and Equal Opportunity finds the Bidder established good faith efforts towards meeting the goals as set forth in the CREO-KC Forms and Instructions for Construction Projects and the City's MBE/WBE Ordinance.

Bidder: Superior Bowen Asphalt Co.

Business Entity Type:

- Missouri Corporation
- Foreign Corporation
- Fictitious Name Registration
- Sole Proprietor
- Limited Liability Company
- Partnership
- Joint Venture
- Other: (Specify) _____

BIDDER

Legal name & address of Bidder, person firm, partnership, corporation, or association submitting Bid:

Phone No: _____

Cell No: _____

Facsimile No: _____

Bidder's E-Mail: _____

Federal ID. No. _____

I hereby certify that I have authority to execute this document on behalf of Bidder, person, firm, partnership, corporation or association submitting Bid.

By: _____
(Signature)

(Print Name)

Title: _____

Date: _____

(Attach corporate seal if applicable)

NOTARY

Subscribed and sworn to before me this _____ day of _____, 20__.

My Commission Expires: _____

Bidder: Superior Bowen Asphalt Co.

ACCEPTANCE OF BID

CITY, by executing this Bid Form/Contract, hereby accepts Bidder's Bid and this Bid Form/Contract that incorporates all other Contract Documents shall constitute the Contract between the Parties.

CITY shall pay CONTRACTOR for completion of the Work in accordance with the Contract Documents a maximum amount of Seven Million Five Hundred Thousand Dollars, (\$ 7,500,000.00). The Contract Price includes:

00412 Unit Prices, included in the Bid, a copy of which is attached

By executing this Bid Form/Contract, CITY accepts Bidder's offer for the Contract Price stated above and this Bid Form/Contract that incorporates all other Contract Documents shall constitute the Contract between the parties

City of Kansas City, Missouri (OWNER or City)

Approved as to form:

Assistant City Attorney

I hereby certify that there is a balance, otherwise unencumbered, to the credit of the appropriation to which the foregoing expenditure is to be charged, and a cash balance, otherwise unencumbered, in the treasury, to the credit of the fund from which payment is to be made, each sufficient to meet the obligation hereby incurred.

Director of Finance (Date)



Unit Prices

Contract Number: 60XX0028/9835

Project Title: WD Asphalt and Concrete, City-Wide

NOTE: IN THE EVENT OF DISCREPANCY, UNIT PRICE SHALL GOVERN.

Item No.	Unit	Est Quantity	Item Description:	Unit	Extension
1	EACH	400	Small Asphalt In-Place 1: <200 SQ FT		
2	SQ-FT	200,000	Asphalt Surface In-Place 2: 200 - 1,700 SQ FT		
3	TON	6,300	Asphalt Surface In-Place 3: >1,700 SQ FT		
4	SQ-FT	425,000	2" mill and Asphalt Engineering for Water Main Replacements		
5	N/A	N/A	Not Used		
6	CU-YD	3,600	Concrete Base In-Place		
7	SQ-FT	720,000	Two (2) Inch Depth Cold Milling >200 SQFT		
8	CU-YD	110	Flowable Fill, placed		
9	CU-YD	240	Untreated Compacted Aggregate Backfill, placed		
10	EACH	35	Water Valve Adjustment		
11	EACH	5	Sewer Manhole Adjustment Ring		
12	EACH	5	Adjustable Sewer Manhole Ring and Cover		
13	N/A	N/A	Not Used		
14	LIN-FT	6,300	Portland Cement Concrete Curb		
15	EACH	TBD	Rapid Response priority work order		
16	SQ-FT	360	Concrete Steps		
17	SQ-FT	450	Brick/Stone Walk or Border		
18	SQ-FT	29,000	Four (4) Inch PCC Sidewalk (Non-Reinforced)		
19	SQ-FT	1,250	Six (6) Inch PCC Sidewalk (Non-Reinforced)		
20	SQ-FT	3,100	10" Concrete Street		
21	SQ-FT	36,000	Six (6) Inch PCC Driveway (Non-Reinforced)		
22	SQ-FT	2,600	Eight (8) Inch PCC Driveway (Non-Reinforced)		
23	SQ-FT	2,300	ADA Accessible Ramps With Detectable Warning		
24	SQ-FT	1,500	Four (4) Inch PCC Sidewalk (Reinforced)		
25	SQ-FT	1,250	Six (6) Inch PCC Sidewalk (Reinforced)		
26	EACH	TBD	Other Special Construction		
27	SQ-FT	1,800	Six (6) Inch PCC Driveway (Reinforced)		
28	SQ-FT	1,300	Eight (8) Inch PCC Driveway (Reinforced)		
29	SQ-FT	450	Concrete Stamping and/or Coloring Markup		
30	CU-YD	1,100	Fill Dirt, placed		
31	SF	450,000	Seeding		
32	SF	4,500	Sodding		
33	SF-INCH	720,000	Top Soil in-place per inch depth (2" minimum depth)		
34	EACH	TBD	Planting		
35	EACH	TBD	Fencing		
36	EACH	TBD	Special Traffic Control Signage		
37	LF	26,000	Pavement Markings		
38	EACH	TBD	Walls		
39	N/A	N/A	Not Used		
40	EACH	400	Small Cold Milling <200 SQFT		
41	EACH	50	Flush embedment of City-Provided Steel Plate(s)		
42	EACH	12	Monthly Administration Charge		
43	EACH		Monthly Performance Add/Subtract		
44	EACH	TBD	Unnecessary Trip Charge by Contractor Crew		
45	EACH	TBD	Unnecessary Trip Charge by City Inspector (deduct)		
			TOTAL BID ITEMS #1 THROUGH #45		

**CREO KC INSTRUCTIONS
FOR CONSTRUCTION CONTRACTS**

PART A. ECONOMIC EQUITY & INCLUSION GOALS--MBE/WBE PROGRAM

I. City's Economic Equity & Inclusion Goals--MBE/WBE Program.

- A. The City has adopted an Economic Equity & Inclusion Goals--Minority/Women Business Enterprise ("MBE/WBE") Program (Sections 3-421 through 3-469, Code of Ordinances) (the "Program") to implement the City's policy of supporting the fullest possible participation in City contracts and change orders of firms owned and controlled by minorities and women. Each construction contract may have an MBE and/or WBE goal for participation. An MBE or WBE goal is a numerical objective the City has set for the contract that may be awarded pursuant to these bid specifications. Goals are stated as a percentage of contract dollars. For example, if an MBE goal for a contract is 10% and a Bidder submits a bid of \$100,000, the goal for MBE participation would equal \$10,000. The specific MBE/WBE goals on this contract are set forth elsewhere in the bid specifications.
- B. These Civil Rights & Equal Opportunity Department ("CREO KC") Forms & Instructions are part of the BIDDING DOCUMENTS and CONTRACT DOCUMENTS as defined in the General Conditions. By submitting a Bid, the Bidder agrees, as a material term of the contract, to carry out the City's MBE/WBE Program by making good faith efforts to include certified MBE/WBEs in the contract work to the extent of the goals listed for the contract and to the fullest extent consistent with submitting the lowest and best bid to the City. Bidder agrees that the Program is incorporated into this document and agrees to follow the Program. Although it is not a requirement that a Bidder in fact meet or exceed both the MBE and WBE Goals, it is a requirement for approval of the Bid that a Bidder objectively demonstrate to the City that good faith efforts have been made to meet the Goals. Bidders must attempt to meet both the MBE and WBE goals and request a waiver if either is not met.
- C. The following CREO KC Forms are attached and must be used for MBE/WBE submittals:
1. Contractor Utilization Plan/Request for Waiver (CREO KC Form 8); and
 2. Letter of Intent to Subcontract (CREO KC Form 00450.01); and
 3. Timetable for MBE/WBE Utilization (CREO KC Form 10); and
 4. Request for Modification or Substitution (CREO KC Form 11); and
 5. Contractor Affidavit for Final Payment (Form 01290.14); and
 6. Subcontractor Affidavit for Final Payment (Form 01290.15).

Warning: The City only gives MBE/WBE credit for a Bidder's use of City certified MBE/WBEs. A certified MBE/WBE firm is a firm that has been certified by the City's Civil Rights & Equal Opportunity Department as such. An MBE/WBE firm must be certified before the date on which the contractor utilization plan is due. Certified MBEs and WBEs are listed in the M/W/DBE Kansas City Mo. Online Directory, which is available on the City's website at www.kcmo.org. Before a Bidder submits a bid, Bidder



should contact CREO KC and consult the directory to make sure any firm proposed for use for MBE/WBE participation has been certified.

II. Required Submissions Following Bid Opening.

A. Bidder must submit the following documents within forty-eight (48) hours of bid opening:

1. **Contractor Utilization Plan/Request for Waiver (CREO KC Form 8).** This form states a Bidder's plan to use specific certified MBE/WBEs in the performance of the contract and includes the following:
 - a. The work to be performed by each MBE/WBE and the amounts each is to be paid for the work; and
 - b. The name, address, race or ethnic origin, gender and employer identification number or social security number of each MBE/WBE that will perform the work.
 - c. An automatic request for waiver in the event Bidder has not met or exceeded the MBE and/or WBE goals for the contract but believes that it has made good faith efforts to meet or exceed the goals and desires a waiver of the goals. If a waiver is requested, CREO KC will examine the Bidder's documentation of good faith efforts and make a recommendation to grant or deny the waiver. CREO KC will recommend a waiver be granted only if the Bidder has made good faith efforts to obtain MBE/WBE participation.
2. **Letter(s) of Intent to Subcontract (CREO KC Form 00450.01).** A letter must be provided from each MBE/WBE listed on the Contractor Utilization Plan. These letters verify that the MBE/WBE has agreed to execute a formal agreement for the work and indicate the scope of work to be performed and the price agreed upon for the work.

III. Required Submission when Requested by City.

A. Bidder must submit the following documents when requested by City:

1. **Timetable for MBE/WBE Utilization (CREO KC Form 10).**
2. **Documentation of good faith efforts.**

IV. Required Monthly Submissions during term of Contract.

A. Bidder must submit the following report on a monthly basis if awarded the contract:

1. **M/WBE Monthly Utilization Report.** This report must be submitted to the Director by the 15th of each month. Failure to submit timely reports may result in delays in processing of current and future contract approvals and payment applications. The method of submission of this report is through the B2GNow Diversity Management System (B2GNow).

V. Required Submittals for Final Contract Payment.

A. Contractor must submit the following documents with its request for final payment under

the contract:

1. **Contractor Affidavit for Final Payment (Form 01290.14)**
2. **Subcontractor Affidavit(s) for Final Payment (Form 01290.15)**
3. **Final B2GNow Monthly Contract Audit Report with all payment audits confirmed.**

VI. Additional Submittals.

- A. Contractor may be required to make additional submittals during the term of the Contract, including **Request for Modification or Substitution (CREO KC Form 11)**. Refer to Section IX, Modification of the Contractor Utilization Plan or Substitution of an MBE/WBE, for additional instructions on when this form must be submitted.

VII. MBE/WBE Participation Credit.

- A. The following shall be credited towards achieving the goals:
1. The total contract dollar amount that a prime contractor has paid or is obligated to pay to a subcontractor that is a certified MBE or WBE, except as otherwise expressly provided for herein.
 2. The total contract dollar amount that a prime contractor that is a certified MBE or WBE performed itself.
 3. Sixty percent (60%) of the total dollar amount paid or to be paid by a prime contractor to obtain supplies or goods from a supplier who is a certified MBE or WBE.
 4. Ten percent (10%) of the total dollar amount paid or to be paid by a prime contractor to obtain supplies or goods from a supply broker who is a certified MBE or WBE.
 5. One hundred percent (100%) of the total dollar amount paid or to be paid by a prime contractor to a manufacturer of construction supplies who is a certified MBE or WBE.
 6. Subcontractor participation with a lower tier MBE/WBE subcontractor using one of the above methods of participation.
- B. **NO CREDIT**, however, will be given for the following:
1. Participation in a contract by a MBE or WBE that does not perform a commercially useful function as defined by the Program; and
 2. Any portion of the value of the contract that an MBE or WBE subcontractor subcontracts back to the prime contractor or any other contractor who is not a qualified MBE/WBE; and
 3. Materials and supplies used on the contract unless the MBE/WBE is responsible for negotiating the price, determining quality and quantity, ordering the materials and installing (where applicable) and paying for material itself; and
 4. Work performed by an MBE or WBE in a scope of work other than that in which the MBE or WBE is currently certified.



VIII. Methods for Securing Participation of MBE/WBEs and Good Faith Efforts.

- A. A bidder is required to make good faith efforts to achieve the MBE/WBE goals. Good faith efforts are efforts that, given all relevant circumstances, a Bidder actively and aggressively seeking to meet the goals can reasonably be expected to make. Good faith efforts must be made before the Bidder submits a Contractor Utilization Plan, in other words, within 48 hours of bid opening. However, efforts made to increase participation of MBEs and WBEs following submission of the CUP can be considered as evidence of good faith efforts to meet the goals.
- B. In evaluating good faith efforts, the Director of CREO KC will consider whether the Bidder has performed the following, along with any other relevant factors:
1. Advertised for at least 15 calendar days prior to the bid or proposal due date opportunities to participate in the contract in general circulation media, trade and professional association publications, small and minority business media, and publications of minority and women's business organizations which are included in a list along with their current contact information identified on the directory as the list of publications available to publish such advertisements, which list shall be updated by CREO KC no less than every three (3) month.
 2. Sent written notices at least fifteen (15) calendar days prior to the bid or proposal due date containing the information required in section (9) below, by certified mail, e-mail, or facsimile, to at least 80% of MBEs and WBEs which are included in a list along with their contact information identified on the directory as the list of organizations available to receive such notices, which list shall be updated by CREO KC no less than every three (3) months.
 3. Sent written notices, containing the information required by section (9) below, by certified mail, e-mail or facsimile, to at least 80% of MBEs and WBEs listed on the directory certified in the applicable scopes of work for the particular bid soliciting their participation in the contract at least 15 calendar days prior to the bid or proposal due date.
 4. Attempted to identify portions of the work for qualified MBE and/or WBE participation in order to increase the likelihood of meeting the goals, including breaking down contracts into economically feasible units that take into consideration the capacity of available MBE/WBEs appearing on the CREO KC directory.
 5. At any time prior to submission of the CUP or submittal of a request for modification of a CUP, requested assistance in achieving the goals from the Director and acted on the Director's recommendations.
 6. Conferred with certified MBEs and WBEs which inquired about or responded to the bid solicitation and explained to such MBEs and WBEs the scope and requirements of the work for which their bids or proposals were solicited, and if not all certified MBEs and WBEs in the particular scopes listed on the directory have inquired about or responded to the bid solicitation for each scope of work, then contact by certified mail, e-mail or telephone the greater of ten (10) or 80% of additional certified MBEs and WBEs in the particular scopes of work listed on the directory and offer to confer with such MBEs and WBEs for such particular scope of work and request such MBEs



and WBEs to submit a proposal.

7. Attempted to negotiate in good faith with certified MBEs and WBEs which responded to the bid solicitation or those certified MBEs and WBEs that were conferred with as contemplated in section (6) above, and other qualified MBEs and WBEs, at the option of the bidder, proposer, or contractor, as applicable, to perform specific subcontracts, not rejecting them as unqualified without sound reasons based on a thorough investigation of their capabilities by the bidder, proposer, or contractor; in the event an MBE or WBE is the low bid, but rejected as unqualified, the bidder, proposer, or contractor and the director or board, as applicable, shall provide sound reasons for rejecting such MBE or WBE.
8. Attended pre-bid meeting when such meetings were indicated in the solicitation of bids or otherwise by the bidder, proposer, or contractor, as applicable or by the director provided the director provides written direction to the bidder, proposer, or contractor at the time the goals are recommended.
9. Written notices and advertisements to be provided pursuant to sections (1), (2) and (3) above shall include the following information:
 - a. The bid due date;
 - b. The name of the project;
 - c. The address or general location of the project;
 - d. The location of plans and specifications for viewing;
 - e. Contact information of the prime contractor;
 - f. A general description of the scopes of work that are the subject of the solicitation;
 - g. The goals established for the applicable contract, and if the goals are still subject to board approval, then a statement that the goals as stated are preliminary and are subject to board approval;
 - h. If the project or any portion of the project is subject to prevailing wage then a statement that all or a portion of the project will be subject to prevailing wage, as applicable; and if only a portion of the scopes are subject to prevailing wage, then identification of such scopes provided that such scopes are known as of the time of bid solicitation;
 - i. The date and time of any pre-bid meeting(s), if any, which have been scheduled by the bidder, proposer, contractor or developer as of the bid solicitation; and

Any other information deemed relevant by the bidder, proposer, contractor or developer, as applicable, or the director to the extent the director provides written direction to the bidder, proposer, contractor or developer of such additional information at the time the goals are recommended by the director. 8. Within five (5) working days after drawing the bid specifications, send certified letters, verifiable e-mails or proof of facsimiles to certified MBEs and WBEs listed in the M/W/DBE Kansas City Mo. Online Directory.

- C. A Bidder may be required to give the City documentation to prove that it made good faith efforts. The Bidder will be contacted by the City with further instructions about when this documentation must be submitted.

IX. Modification of the Contractor Utilization Plan or Substitution of an MBE/WBE.

- A. After bid opening, a Bidder or Contractor may need to substitute an MBE and/or WBE or request that the amount of MBE/WBE participation listed in its Contractor Utilization Plan be modified. Bidder or Contractor must file a **Request for Modification or Substitution (CREO KC Form 11) prior to actual substitution and within a reasonable time after learning that a modification or substitution is necessary.** The Director may approve substitutions or modifications and upon approval, the modifications and substitutions will become an amendment to the Contractor Utilization Plan. Modifications or substitutions may be approved when:
 - 1. The Director finds that the Bidder or Contractor made and provided evidence of good faith efforts to substitute the MBE/WBE listed on the Contractor Utilization Plan with other certified MBE/WBEs for the scope of work or any other scope of work in the contract; and
 - 2. The Bidder or Contractor has not attempted intentionally to evade the requirements of the program and it is in the best interests of the City to allow a modification or substitution; and
 - 3. The Director also finds one of the following:
 - a. The listed MBE/WBE is non-responsive or cannot perform; or
 - b. The listed MBE/WBE has increased its previously quoted price to the bidder, proposer or contractor without a corresponding change in the scope of the work; or
 - c. The listed MBE/WBE has committed a material default or breach of its contract with the contractor; or
 - d. Requirements of the scope of work of the contract have changed and render subcontracting not feasible or not feasible at the levels required by the goals established for the contract; or
 - e. The listed MBE/WBE is unacceptable to the contracting department; or
 - f. The listed MBE/WBE thereafter had its certification revoked; or
- B. A modification shall not be made unless the modification or substitution has first been requested and approved by the Director. Once a modification has been made, a Construction Contractor Employee Identification Report (CREO KC Form 0485.04) for the newly approved subcontractor must be submitted at least ten (10) days prior to the approved subcontractor commencing work on a City contract.

X. Appeals.

- A. In conformance with the Act, appeals may be made to the City Fairness in Construction Board or Fairness in Professional Services and Goods Board on the following:



1. The grant or denial of a Request for Waiver;
 2. Substitution for an MBE/WBE listed on a Contractor Utilization Plan;
 3. Modification of the percentage of MBE/WBE participation on a Contractor Utilization Plan;
 4. Liquidated Damages;
 5. The amount of MBE/WBE credit the Contractor may receive for MBE/WBE participation identified in the contractor utilization plan.
- B. Any appeal must be filed in writing with the Director within fifteen (15) calendar days of notice of the determination. Mailing, faxing, personal delivery or posting at CREO KC of determinations shall constitute notice. The appeal shall state with specificity why the Bidder or Contractor believes the determination is incorrect
- C. Failure to file a timely appeal shall constitute a waiver of a Bidder's or Contractor's right to appeal such determination and such person shall be estopped to deny the validity of any determination which could have been timely appealed.

XI. Access to Documents and Records.

- A. By submitting a Bid, each Bidder agrees to permit the City, its duly authorized agents or employees, access at all reasonable times to all books and business records of Bidder as may be necessary to ascertain compliance with the requirements of this document and the Act, within ten (10) calendar days of the date of the written request.
- B. All Bidders agree to cooperate with the contracting department and CREO KC in studies and surveys regarding the MBE/WBE program.

XII. Miscellaneous.

- A. A Bidder or Contractor shall bear the burden of proof with regard to all issues on appeal.
- B. In the event of any conflict between this document and the Program, the provisions of the Program shall control. The terms used in this document are defined in the Program.
- C. Oral representations are not binding on the City.
- D. The City Council may waive the requirements of this document and the Program and award the contract to the lowest and best bidder if the City Council determines a waiver is in the best interests of the City.
- E. The Director may grant extensions of time to Bidders to submit Letters of Intent to Subcontract (CREO KC Form 00450.01).

XIII. Liquidated Damages – Economic Equity & Inclusion Goals--MBE/WBE Program.

- A. If Contractor fails to achieve the MBE/WBE goals stated in its Contractor Utilization Plan, as amended, the City will sustain damages, the exact extent of which would be difficult or impossible to ascertain. Therefore, in order to liquidate those damages, the monetary difference between either (1) the amount of the MBE/WBE goals set forth in the Contractor Utilization Plan, as amended, or (2) the goals established (whichever is lower) and the amount actually paid to qualified MBEs and WBEs for performing a commercially useful function will be deducted from the Contractor's payments as

liquidated damages. In determining the amount actually paid to qualified MBEs and WBEs, no credit will be given for the portion of participation that was not approved by the Director, unless the Director determines that the Contractor acted in good faith. No deduction for liquidated damages will be made when, for reasons beyond the control of the Contractor, the MBE/WBE participation stated in the Contractor Utilization Plan, as amended and approved by the Director is not met.

PART B. CONSTRUCTION EMPLOYMENT PROGRAM REQUIREMENTS

IMPORTANT: This Part B is applicable to City construction contracts estimated by the City prior to solicitation as: (1) requiring more than 800 construction labor hours and (2) valued in excess of \$300,000.00. This program is distinguished from the M/WBE Program in that it is based on workforce hours of the Bidder and *all* its participating subcontractors rather than the actual contract value of work. The instructions herein detail the specifics related to this program. This program is in *addition* to the M/WBE program.

I. City's Construction Employment Program.

- A. The City has adopted a Construction Employment Program (Sections 3-501 through 3-525, Code of Ordinances) (the "Workforce Program" or "Program") to implement the City's policy of supporting the fullest possible utilization of minority and women workers in the construction industry.
- B. The minimum workforce goals are currently set by ordinance at 10% for minorities and 2% for women. These goals are separate from M/WBE goals. Public recognition may be provided if the bidder achieves at least twice the minimum participation.
- C. Construction contracts subject to the Workforce Program and the company-wide and project-specific workforce goals ("workforce goals") are those contracts to construct, reconstruct, improve, enlarge or alter any fixed work that is estimated by the City prior to solicitation to: (1) require more than 800 construction labor hours, (2) has estimated costs that exceed \$300,000.00, and (3) involve the expenditure of public funds.
- D. The successful bidder may meet company-wide goals by counting the bidder's utilization of minorities and women throughout the Kansas City metropolitan statistical area. In addition, the successful Bidder is responsible to ensure that it and its subcontractors cumulatively make good faith efforts to meet project-specific goals for utilization of minorities and women.
- E. These Civil Rights & Equal Opportunity Department ("CREO KC") Forms & Instructions are part of the BIDDING DOCUMENTS and CONTRACT DOCUMENTS as defined in the General Conditions. By submitting a Bid, the Bidder agrees, as a material term of the contract, to carry out the City's Construction Employment Program by making good faith efforts to utilize minority and women workers to the fullest extent consistent with submitting the lowest and best bid to the City. Bidder agrees that the Program is incorporated into this document and agrees to follow the Program. Although it is not a requirement that a Bidder in fact meet or exceed the construction employment goals to receive approval from CREO KC, a Bidder not doing so is required to



objectively demonstrate to CREO KC that good faith efforts have been made.

- F. The following reports are to be used for Construction Employment Program submittals:
1. Project Workforce Monthly Report
 2. Company-Wide Workforce Monthly Report

II. Required Submissions.

- A. Within forty-eight (48) hours after bid opening, the construction contractor shall submit the **Construction Employee Identification Report** (CREO KC Form 00485.04) and shall include: the name, home address, job title, sex and race/ethnicity of each person working for the Prime. The individuals to be listed on the form are those which the construction contractor *anticipates* will be performing construction labor hours creditable towards the minimum workforce goals applicable to the construction contractor individually.

The following circumstances also require the submission of a Construction Employee Identification Report:

- a. Prior to contract execution for those City construction contracts awarded pursuant to a request for proposals (RFP), the construction contractor shall submit a **Construction Employee Identification Report** (CREO KC Form 00485.04).
 - b. At least ten (10) days prior to the date upon which any subcontractor is to commence work under a City construction contract, the Prime shall submit a **Construction Employee Identification Report** (CREO KC Form 00485.04) for the subcontractor.
- B. The CREO KC Director has established the B2GNow Diversity Management System (“B2GNOW”) (an online reporting tool) as the preferred method for fulfilling reporting requirements of the Workforce Program. The CREO KC Director will allow paper submission in lieu of on-line submission if the on-line submission process presents a hardship to the contractor.
- C. Bidder must submit the following documents through B2GNow on a monthly basis if awarded the contract:
1. **Project Workforce Monthly Report.** This report is contract specific. This report must be submitted to the Director by the 15th of each month for the Contractor and each subcontractor. It will be utilized to report the Contractor’s own workforce compliance data with regard to the City’s construction contract. Failure to submit timely reports may result in delays in processing of current and future contract approvals and payment applications.
 2. **Company-Wide Workforce Monthly Report.** This report is not contract specific; it is used to report on the utilization of women and minorities, by trade, company-wide. This report must be submitted to the Director by the 15th of each month. It will be utilized to report the Contractor’s own workforce compliance data with regard to



every contract (both privately and publicly funded) that the Contractor has in progress throughout the Kansas City Metropolitan Statistical Area. Failure to submit timely reports may result in delays in processing of current and future contract approvals and payment applications.

III. Submittal Required for Final Contract Payment.

- A. The final Project Workforce Monthly Report(s) and Company-Wide Workforce Monthly Report must be submitted before final payment will be made and/or retainage released. Contractor shall note the submittal of the final reports by notation in the box entitled “Final Report”

IV. Methods for Securing Workforce Participation and Good Faith Efforts.

- A. A bidder is required to make good faith efforts to achieve the construction employment goals and ensure its subcontractors are making good faith efforts to achieve the construction employment goals. If a Bidder or its subcontractors will be unable to secure enough minority and female participation to meet or exceed the construction employment goals, a bidder must, within a reasonable time after so learning, request a waiver or modification of the goals by the Director of CREO KC. The Director will request evidence of the Bidder’s and its’ subcontractors’ good faith efforts to meet the goals. The Director will examine the Bidder’s request and the Bidder’s documentation of good faith efforts for itself and its subcontractors. The Director will examine the Bidder’s request and the Bidder’s documentation of good faith efforts and grant or deny a waiver or modification. The Director will grant a waiver or modification only if the Bidder has made good faith efforts to secure minority and female participation.

IMPORTANT: The Bidder’s subcontractors on a city construction contract must meet the workforce goals collectively. The bidder is responsible to ensure the subcontractors make good faith efforts to meet the workforce goals. Bidders are required to include language in its subcontracts that ensure the subcontractors make good faith efforts to meet or exceed the workforce goals.

- B. In evaluating good faith efforts, the Director will consider whether the Bidder and its subcontractors have performed the following:
 1. For those bidders that are not signatories to a collective bargaining agreement with organized labor:
 - a. Requested in writing the assistance of the Director with respect to efforts to promote the utilization of minorities and women in the workforce and acted upon the Director’s recommendations; and
 - b. Advertised in minority or women trade association newsletters and/or minority or women owned media at least 15 calendar days prior to the utilization of any construction services on the city construction contract and used terminology that sufficiently describes the work available, the pay scale, the application process, and anything else that one might reasonably be expected to be informed of relevant to the position being advertised; and
 - c. Maintained copies of each advertisement and a log identifying the publication and date of publication; and



- d. Conducted real and substantial recruitment efforts, both oral and written, targeting resident, minority and women community-based organization, schools with a significant minority student population, and training organizations serving the recruitment area; and
 - e. Established and maintained a current list of resident, minority and women recruitment sources, providing written notification to the recruitment sources of available employment opportunities, and maintained records of the notices submitted to the organizations and any responses thereto; and
 - f. Maintained a current file for the time period of the city construction contract with the name, address, and telephone number of each resident, minority and woman job applicant, the source of the referral, whether or not the person was hired, and in the event that the applicant was not hired, the reason therefore; and
 - g. Promoted the retention of minorities and women in its workforce with the goals of achieving sufficient annual hours for minorities and women to qualify for applicable benefits; and
 - h. Required by written contract that all subcontractors comply with the above efforts.
2. For those bidders that are signatories to collective bargaining agreements with organized labor:
- a. Requested in writing from each labor union representing crafts to be employed that:
 - i. the labor union make efforts to promote the utilization of residents of the City, minorities and women in the workforce; and
 - ii. the labor union identify any residents of the City, minorities and women in its membership eligible for employment; and
 - b. Collaborated with labor unions in promoting mentoring programs for journeypersons intended to assist minorities and women in increasing retention with the goals of achieving sufficient annual hours to qualify for applicable benefits; and
 - c. Maintained a current file with the name, address, and telephone number of each resident, minority and women worker identified by the labor union, whether or not the person was hired, and in the event the person was not hired, the reason therefore.
 - d. To the extent the good-faith efforts applicable to bidders that are signatories to collective bargaining agreements with organized labor conflict with the procedures implemented by the bidder in order to comply with the relevant bargaining agreement, the bidder shall substitute other procedures as may be approved by the Director in writing, in order to accomplish the purpose and intent of this section.

C. In the event workforce goals are not met or there is anticipation that goals will not be



met, a Bidder will be required to give the City documentation to prove that it and/or its subcontractors made good faith efforts. The Bidder will be contacted by the City with further instructions about when this documentation must be submitted.

V. Access to Documents and Records.

- A. By submitting a Bid, each Bidder agrees to permit the City, its duly authorized agents or employees, access at all reasonable times to all books and business records of Bidder as may be necessary to ascertain compliance with the requirements of this document and the Program, within ten (10) days of the date of the written request. Each bidder further agrees to require, if awarded the contract, that every subcontractor permit the City the same access to documents and records.
- B. All Bidders agree to cooperate with the contracting department and CREO KC in studies and surveys regarding the construction employment program.

VI. Appeals.

- A. In conformance with the Program, appeals may be made to the Construction Workforce Board on the following:
 - 1. Determinations by the Director that a contractor did not meet the construction employment goals and did not make a good faith effort to meet the goals;
 - 2. Recommendations by the Director to assess liquidated damages;
 - 3. Recommendation by the Director that a contractor be declared ineligible to receive any city construction contract for a period of time up to one year.
- B. Any appeal must be filed in writing with the Director within ten (10) working days of notice of the recommendation or determination. The appeal shall state with specificity why the Bidder or Contractor believes the recommendation or determination is incorrect.
- C. Failure to file a timely appeal shall constitute a waiver of a Bidder's or Contractor's right to appeal such determination or recommendation and such person shall be estopped to deny the validity of any order, determination, recommendation or action of CREO KC which could have been timely appealed.

VII. Miscellaneous.

- A. A Bidder or Contractor shall bear the burden of proof with regard to all issues on appeal.
- B. The successful bidder may be required to meet with the Director of CREO KC or the Director's designee for the purpose of discussing the construction employment program, the bidder's efforts to realize the goals, and any other problems and/or issues affecting the realization of the goals or the program in general.
- C. In the event of any conflict between this document and the Program, the provisions of the Program shall control. The terms used in this document are defined in the Program.
- D. Oral representations are not binding on the City.

VIII. Failure to Meet Workforce Goals

- A. If Contractor or its subcontractors fail to achieve the construction employment goals or make good faith efforts to achieve those goals without having previously obtained a

waiver or modification of those goals, the City will sustain damages, the exact extent of which would be difficult or impossible to ascertain. These damages are magnified if the failure to abide by the requirements of the Workforce Program is recurring. Therefore, if the directory finds that the contractor or subcontractor have not met, or made good faith efforts to meet, the construction employment goals for any quarter, the director may:

1. Assess liquidated damages against the construction contractor, as specified in the city construction contract;
2. Require the contractor to attend mandatory training, as specified in the construction contract;
3. Declare the contractor ineligible to receive any city construction contract or participate as a subcontractor under any city construction contract for a period of time up to six months, as specified in the construction contract.

IX. First Source Program

- A. The City has established a labor force recruiting program intended to assist contractors in identifying, interviewing and hiring qualified job applicants residing in Kansas City, Missouri. While the contractor awarded a City construction contract is not prohibited from hiring persons residing outside Kansas City, Missouri, the recruiting resource provided for herein (the “First Source Program”) must be utilized by the contractor subject to the construction employment goals as set forth in this **PART B, CONSTRUCTION EMPLOYMENT PROGRAM REQUIREMENTS**.
- B. The City utilizes the services of the Full Employment Council, Inc., to administer the First Source Program. The contractor shall contact the Full Employment Council within 48 hours of contract award, regardless of whether the contractor has any hiring needs at that time, and within 48 hours following any job vacancy which the contractor reasonably anticipates filling during the term of the City construction contract. The contractor shall comply with the First Source Program requirements as implemented by the Full Employment Council unless otherwise excused in writing by the Director of CREO KC for good cause shown. To ensure compliance with the First Source Program, the contractor shall contact those persons at the Full Employment Council responsible for administering the program, which may be identified by visiting their website at www.feckc.org and clicking on the link for KCMO First Source Hiring Program. The contractor shall not hire any individual to provide construction services on a City construction contract unless the contractor has met the requirements of the First Source Program.
- C. The contractor shall require that its subcontractors utilize the First Source Program to the same extent that the contractor is required to do so, and shall incorporate the requirements of this Section IX into every subcontract. Every subcontractor shall be required to contact the Full Employment Council within 48 hours of subcontract award, regardless of whether the subcontractor has any hiring needs at that time, and within 48 hours following any job vacancy which the subcontractor reasonably anticipates filling during the term of their subcontract on a City construction project.





CONTRACTOR UTILIZATION PLAN/REQUEST FOR WAIVER

Project Number 60XX0028/9835

Project Title WD Asphalt and Concrete, City Wide

(Department Project)

Department

Superior Bowen Asphalt Co, LLC

(Bidder/Proposer)

STATE OF Missouri)

COUNTY OF Jackson) ss

I, Michael Morrison, of lawful age and upon my oath state as follows:

1. This Affidavit is made for the purpose of complying with the provisions of the MBE/WBE submittal requirements on the above project and the MBE/WBE Program and is given on behalf of the Bidder/Proposer listed below. It sets out the Bidder/Proposer's plan to utilize MBE and/or WBE contractors on the project.

2. The project target goals are 10 % MBE and 10 % WBE.

3. Bidder/Proposer assures that it will utilize a minimum of the following percentages of MBE/WBE participation in the above project:

1 BIDDER/PROPOSER PARTICIPATION: 10 % MBE 10 % WBE

1 POST-BID/POST-RFP ESTIMATED BUDGET: \$ 7,400,267.00

4. The following are the M/WBE subcontractors whose utilization Bidder/Proposer warrants will meet or exceed the above-listed Bidder/Proposer Participation. Bidder/Proposer warrants that it will utilize the M/WBE subcontractors to provide the goods/services described in the applicable Letter(s) of Intent to Subcontract, copies of which shall collectively be deemed incorporated herein). (*All firms must currently be certified by Kansas City, Missouri*)

1 Name of M/WBE Firm Tenoch Construction, Inc

Address 912 Scott Ave, Kansas City, KS 66105

Telephone No. 913 671-7706

I.R.S. No. 14-1880826



Name of M/WBE Firm Streetwise, Inc
 Address 13501 Arrington Rd, Grandview, MO
 Telephone No. 816 331-2355
 I.R.S. No. 77-0676750

Name of M/WBE Firm _____
 Address _____
 Telephone No. _____
 I.R.S. No. _____

Name of M/WBE Firm _____
 Address _____
 Telephone No. _____
 I.R.S. No. _____

Name of M/WBE Firm _____
 Address _____
 Telephone No. _____
 I.R.S. No. _____

Name of M/WBE Firm _____
 Address _____
 Telephone No. _____
 I.R.S. No. _____

(List additional M/WBEs, if any, on additional page and attach to this form)

4. The following is a breakdown of the percentage of the total contract amount that Bidder/Proposer agrees to pay to each listed M/WBE:

MBE/WBE BREAKDOWN SHEET

MBE FIRMS:

Name of MBE Firm	Supplier/Broker/Contractor	Subcontract Amount*	Weighted Value**	% of Total Contract
Tenoch Construction	Contractor	\$ 740,027.00	\$ 740,027.00	10.00
_____	_____	_____	_____	_____
_____	_____	_____	_____	_____
_____	_____	_____	_____	_____
_____	_____	_____	_____	_____
_____	_____	_____	_____	_____
_____	_____	_____	_____	_____



TOTAL MBE \$ / TOTAL MBE %:	<u>\$ 740,027.00</u>	<u>10.00 %</u>
------------------------------------	----------------------	----------------

WBE FIRMS:

Name of WBE Firm	Supplier/Broker/Contractor	Subcontract Amount*	Weighted Value**	% of Total Contract
Tenoch Construction	Contractor	\$ 666,025.00	\$ 666,025.00	9.00
Streetwise	Contractor	\$ 74,003.00	\$ 74,003.00	1.00
TOTAL WBE \$ / TOTAL WBE %:		<u>\$ 740,028.00</u>		<u>10.00 %</u>

*“Subcontract Amount” refers to the dollar amount that Bidder/Proposer has agreed to pay each M/WBE subcontractor as of the date of contracting and is indicated here solely for the purpose of calculating the percentage that this sum represents in proportion to the total contract amount. Any contract amendments and/or change orders changing the total contract amount may alter the amount due an M/WBE under their subcontract for purposes of meeting or exceeding the Bidder/Proposer participation.

**“Weighted Value” means the portion of the subcontract amount that will be credited towards meeting the Bidder/Proposer participation. See CREO KC Forms and Instructions for allowable credit and special instructions for suppliers.

- Bidder/Proposer acknowledges that the monetary amount to be paid each listed M/WBE for their work, and which is approved herein, is an amount corresponding to the percentage of the total contract amount allocable to each listed M/WBE as calculated in the MBE/WBE Breakdown Sheet. Bidder/Proposer further acknowledges that this amount may be higher than the subcontract amount listed therein as change orders and/or amendments changing the total contract amount may correspondingly increase the amount of compensation due an M/WBE for purposes of meeting or exceeding the Bidder/Proposer participation



6. Bidder/Proposer acknowledges that it is responsible for considering the effect that any change orders and/or amendments changing the total contract amount may have on its ability to meet or exceed the Bidder/Proposer participation. Bidder/Proposer further acknowledges that it is responsible for submitting a Request for Modification or Substitution if it will be unable to meet or exceed the Bidder/Proposer participation set forth herein.
7. If Bidder/Proposer has not achieved both the M/WBE goal(s) set for this Project, Bidder/Proposer hereby requests a waiver of the MBE and/or WBE goal(s) that Bidder/Proposer has failed to achieve
8. Bidder/Proposer will present documentation of its good faith efforts, a narrative summary detailing its efforts and the reasons its efforts were unsuccessful when requested by the City.
9. I hereby certify that I am authorized to make this Affidavit on behalf of the Bidder/Proposer named below and who shall abide by the terms set forth herein:

Bidder/Proposer primary contact: Superior Bowen Asphalt Co, LLC
 Address: 520 W Pennway, Kansas City, MO 64108

 Phone Number: 816 921-8200
 Facsimile number: _____
 E-mail Address: mmorrison@superiorbowen.com

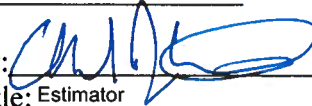
By: 
 Title: Estimator
 Date: 11/29/23
 (Attach corporate seal if applicable)

Subscribed and sworn to before me this 29 day of November, 2023.

My Commission Expires: 2/28/26 Callie Grace Starks
 Notary Public



Contractor Utilization Plan Approval Form

Prepared by: Leona Walton

e-Builder users: Approval Form must be completed and attached in PDF format where indicated. CUP/LOIs must be attached where indicated, or as supporting documents.

Date: 11/30/23

Contract/Project Number: 9835 / 60XX0028	Project Name: WD Asphalt and Concrete, City Wide
Developer/Prime: Superior Bowen Asphalt Co., LLC	Contact Name: Mike Morrison
Address: 520 W. Pennway, KCMO 64108	Email: mmorrison@superiorbowen.com

Full Contract Value: \$ 7,500,000.00

Funding: City State Federal CO-OP Grant: Other:

Project Requirements: M/WBE DBE Section 3 N/A

Tax Incentive: LCRA TIF PIEA N/A Other:

Prevailing Wage: Yes No

Davis-Bacon: Yes No

Construction Employment Program: Yes: Workforce goals are 10% Minority & 2% Women. There are over 800 Workforce hours and project cost is \$300,000 or more.
 NO: Workforce hours are less than 800 and project cost is less than \$300,000.

Contract Goals:	Contractor Utilization Plan Achievement:
Self-Perform: <u> yes </u> %	Self-Perform: <u> yes </u> %
MBE: <u> 10 </u> %	MBE: <u> 11 </u> %
WBE: <u> 10 </u> %	WBE: <u> 11 </u> %
Non-certified firms: <u> yes </u> %	Non-certified firms: <u> yes </u> %

Contract Type (select one): Construction Design-Build Design Professional Professional Services
 General Services Facilities Maintenance/Repair/Renovation Concessions Co-operative
 Revenue Sharing Non-Municipal Agency Other Goods & Services Other _____

Project Manager: Todd Rohr Email: Todd.Rohr@kcmo.org
 Additional Information:

This document is submitted with all available facts. Intentionally falsifying this document or omitting pertinent facts is grounds for disciplinary action pursuant to KCMO Human Resources Rules & Policy Manual (eff. August 4, 2014).

FOR CIVIL RIGHTS & EQUAL OPPORTUNITY DEPARTMENT (CREO) USE ONLY:

The Contractor Utilization Plan is:

Approved Disapproved

 10 % MBE 10 % WBE % DBE

The Request for Good Faith Efforts Waiver is:

Approved Disapproved Not Applicable

Appeal Sent to FICB or Incentive Agency? Yes FICB Incentive Agency No

CREO Signature: Mark Runge Date: 12/12/2023

Comments:



**Civil Rights & Equal Opportunity Department
Economic Equity & Inclusion
Nondiscrimination & Equal Opportunity Review Form**

Date: 11/30/2023
Form Prepared By: Leona Walton

Contract/Project Number: 9835 / 60XX0028	Project Name: WD Asphalt and Concrete, City Wide
Developer/Prime: Superior Bowen Asphalt Co., LLC	Contact Information: Mike Morrison/morrison@superiorbowen.com/816-921-8200
Final Contract Value: \$ 7,500,000.00	Project Manager: Todd Rohr/Todd.Rohr@kcmo.org/816-513-0323

Funding: City State Federal CO-OP Grant: Other:

Project Requirements: M/WBE DBE Section 3 N/A

Tax Incentive: LCRA TIF PIEA Ch. 100 Other: N/A

Prevailing Wage: Yes No

Davis-Bacon: Yes No

Construction Employment Program: Yes: Workforce goals are 10% Minority & 2% Women. There are over 800 Workforce hours and project cost is \$300,000 or more.
 No: Workforce hours are less than 800 and project cost is less than \$300,000.

Contracts & Leases	Nondiscrimination
Ch. 3 Article IV: <u>yes</u>	Ch. 38: <u>yes</u>
RSMo 213: <u>yes</u>	Title VI: <u>yes</u>
MWDBE: <u>yes</u>	Prevailing Wage and Labor Standards: <u>yes</u>
SLBE: <u>n/a</u>	RSMo 34 Anti-Discrimination Against Israel: <u>yes</u>

Contract Type:

Construction Design-Build Design Professional Professional Services

General Service Concession Other Goods & Services Non-Municipal Agency

Co-Operative Revenue Sharing Facilities Maintenance/Repair/Renovation

Other:

Additional Information:

This document is submitted with all available facts. Intentionally falsifying this document or omitting pertinent facts is grounds for disciplinary action pursuant to KCMO Human Resources Rules & Policy Manual (eff. August 4, 2014).

FOR CIVIL RIGHTS & EQUAL OPPORTUNITY DEPARTMENT (CREO) USE ONLY:

The Document is:

Approved Disapproved

Changes Needed:

Federal Provisions Included:

Approved Disapproved Not Applicable

CREO Signature: Mark Runge Date: 12/12/2023

DocuSigned by: 6AFEC964B0364TA...

Comments: CREO Assurances to be attached to contract.



Civil Rights and Equal Opportunity Department Civil Rights and Wage Assurances

Non-discrimination in Employment. Contractor shall not discriminate against any employee or candidate for employment on the basis of an individual's race, hair texture or hair style associated with an individual's race, color, sex, religion, national origin, or ancestry, disability, sexual orientation, gender identity, age, or in any other manner prohibited by Chapter 38 of the City Code. Contractor shall not engage in any discrimination as prohibited by Chapter 3 of the City Code.

Ban the Box in Hiring and Promotion.

(a) Pursuant to Section 38-104, City Code Ordinances, Contractor shall not base a hiring or promotional decision on an applicant's criminal history or sentence related thereto, unless the employer can demonstrate that the employment-related decision was based on all information available including consideration of the frequency, recentness and severity of a criminal record and that the record was reasonably related to the duties and responsibilities of the position.

(b) Notwithstanding subsection (a), Contractor may inquire about an applicant's criminal history after it has been determined that the individual is otherwise qualified for the position, and only after the applicant has been interviewed for the position. Any such inquiry may be made of all applicants who are within the final selection pool of candidates from which a job will be filled.

(c) This provision shall not apply to positions where employers are required to exclude applicants with certain criminal convictions from employment due to local, state or federal law or regulation.

Title VI of the Civil Rights Act of 1964. Title VI of the Civil Rights Act of 1964 requires that no person in the United States shall, on the grounds of race, color, or national or origin (including limited English proficient individuals), be excluded from participation in, be denied the benefits of, or be subjected to discrimination under any program or activity receiving federal financial assistance. The City of Kansas City, Missouri requires compliance with the requirements of Title VI in all of its programs and activities regardless of the funding source.

Contractor shall not discriminate on the grounds of race, color, or national or origin (including limited English proficient individuals).

Quality Services Assurance Act. If this Contract exceeds \$160,000.00, Contractor certifies Contractor will pay all employees who will work on this Contract in the city limits of Kansas City, Missouri at least \$15.00 per hour in compliance with the City's Quality Services Assurance Act,



Civil Rights and Equal Opportunity Department Civil Rights and Wage Assurances

Section 3-66, Code of Ordinances or City has granted Contractor an exemption pursuant to the Quality Services Assurance Act.

Anti-Discrimination Against Israel. If this Contract exceeds \$100,000.00 and Contractor employs at least ten employees, pursuant to Section 34.600, RSMo., by executing this Contract, Contractor certifies it is not currently engaged in and shall not, for the duration of this contract, engage in a boycott of goods or services from the State of Israel; companies doing business in or with Israel or authorized by, licensed by, or organized under the laws of the State of Israel; or persons or entities doing business in the State of Israel.

Affirmative Action. If this Contract exceeds \$300,000.00 and Contractor employs fifty (50) or more people, Contractor shall comply with City's Affirmative Action requirements in accordance with the provisions of Chapter 3 of City's Code, the rules and regulations relating to those sections, and any additions or amendments thereto; in executing any Contract subject to said provisions, Contractor warrants that it has an affirmative action program in place and will maintain the affirmative action program in place for the duration of the Contract. Contractor shall not discriminate against any employee or applicant for employment because of race, color, sex, religion, national origin or ancestry, disability, sexual orientation, gender identity or age in a manner prohibited by Chapter 3 of City's Code. Contractor shall:

- (a) Execute and submit the City of Kansas City, Missouri CREO Affirmative Action Program Affidavit warranting that the Contractor has an affirmative action program in place and will maintain the affirmative action program in place for the duration of the Contract.
- (b) Submit, in print or electronic format, a copy of Contractor's current certificate of compliance to the City's Civil Rights and Equal Opportunity Department (CREO) prior to receiving the first payment under the Contract, unless a copy has already been submitted to CREO at any point within the previous two (2) calendar years. If, and only if, Contractor does not possess a current certification of compliance, Contractor shall submit, in print or electronic format, a copy of its affirmative action program to CREO prior to receiving the first payment under the Contract, unless a copy has already been submitted to CREO at any point within the previous two (2) calendar years.
- (c) Require any Subcontractor awarded a subcontract exceeding \$300,000.00 to affirm that Subcontractor has an affirmative action program in place and will maintain the affirmative action program in place for the duration of the subcontract.
- (d) Obtain from any Subcontractor awarded a subcontract exceeding \$300,000.00 a copy of the Subcontractor's current certificate of compliance and tender a copy of the same, in print or



Civil Rights and Equal Opportunity Department Civil Rights and Wage Assurances

electronic format, to CREO within thirty (30) days from the date the subcontract is executed. If, and only if, Subcontractor does not possess a current certificate of compliance, Contractor shall obtain a copy of the Subcontractor's affirmative action program and tender a copy of the same, in print or electronic format, to CREO within thirty (30) days from the date the subcontract is executed.

City has the right to take action as directed by City's Civil Rights and Equal Opportunity Department to enforce this provision. If Contractor fails, refuses or neglects to comply with the provisions of Chapter 3 of City's Code, then such failure shall be deemed a total breach of this Contract and this Contract may be terminated, cancelled or suspended, in whole or in part, and Contractor may be declared ineligible for any further contracts funded by City for a period of one (1) year. This is a material term of this Contract.

Compliance with Laws. Contractor shall comply with all federal, state and local laws, ordinances and regulations applicable to the work and this Agreement. Contractor shall maintain in effect all the licenses, permissions, authorizations, consents and permits that it needs to carry out its obligations under this Agreement.

Prevailing Wage. If the Agreement exceeds \$75,000.00 and any of the Services performed by Contractor includes construction, reconstruction, improvement, enlargement, alteration, painting and decorating, or major repair, that is subject to the Missouri Prevailing Wage Law (Section 290.210, RSMo – 290.340, RSMo), Contractor shall immediately notify the City prior to performing Services so the parties can execute an agreement that incorporates, the appropriate Wage Order. Contractor shall comply with all requirements of Section 290.210, RSMo – 290.340, RSMo even if Contractor fails to notify the City.



LETTER OF INTENT TO SUBCONTRACT

Check one:	
Original LOI:	<input checked="" type="checkbox"/>
Updated LOI:	<input type="checkbox"/>

Project Name/Title WD Asphalt & Concrete, City Wide

Project Location/Number 60XX0028/9835

PART I: Prime Contractor Superior Bowen Asphalt Co, LLC agrees to enter into a contractual agreement with M/W/DBE Subcontractor Tenoch Construction, Inc who will provide the following goods/services in connection with the above-reference contract: [Insert a brief narrative describing goods/services to be provided. Broad Categorizations (e.g., "electrical," "plumbing," etc.) or the listing of NAICS Codes in which M/W/DBE Subcontractor is certified are insufficient and may result in denial of this Letter of Intent to Subcontract.]
Concrete base and sidewalk

for an estimated amount of \$ 666,025 (or 9 % of the total estimated contract value.)

- M/WBE Vendor type:
- Subcontractor/manufacturer (counts as 100% of contract value towards goals)
 - Supplier (counts as 60% of the total dollar amount paid or to be paid by a prime contractor for supplies or goods towards goals)
 - Broker (counts as 10% of the total dollar amount paid or to be paid by a prime contractor for supplies or goods towards goals)

M/W/DBE Subcontractor is, to the best of Prime Contractor's knowledge, currently certified with the City of Kansas City's Civil Rights & Equal Opportunity Department to perform in the capacities indicated herein. Prime Contractor agrees to utilize M/W/DBE Subcontractor in the capacities indicated herein, and M/W/DBE Subcontractor agrees to work on the above-referenced contract in the capacities indicated herein, contingent upon award of the contract to Prime Contractor.

PART 2: This section is to be completed by the M/W/DBE subcontractor listed above. Please attach additional sheets as needed for more than one intended sub-tier contract. **IMPORTANT: Falsification of this document will result in denial and other remedies available under City Code.**

- Select one:
- The M/W/DBE Subcontractor listed above **IS NOT** subcontracting any portions of the above-stated scope of work(s). (Continue to Part 3.)
 - The M/W/DBE Subcontractor listed above **IS** subcontracting certain portions of the above stated scope of work(s) to:

(1) Company name: _____

Full address: _____

Street number and name

City, State and Zip Code

Primary contact: _____

Name

Phone

a) This subcontractor is (select one): MBE WBE DBE N/A

i: If this subcontractor is an M/W/DBE certified with the City of Kansas City, Missouri, a separate Letter of Intent must be attached to this document.

ii. If this subcontractor is NOT a certified M/W/DBE certified with the City of Kansas City, Missouri, the firm must still be listed for reporting purposes but a Letter of Intent is not required.

b) Scope of work to be performed: _____

c) The dollar value of this agreement is: _____

PART 3:

**NOTE: SIGNATURES AND NOTARIZATIONS REQUIRED FOR NEW LETTERS OF INTENT (LOI);
SIGNATURES ONLY FOR UPDATED LOI (ADDING VALUE TO EXISTING CONTRACT).**

PRIME CONTRACTOR BUSINESS NAME: Superior Bowen Asphalt Co, LLC

Michael Morrison
Signature: Prime Contractor
Estimator
Title

Michael Morrison
Print Name
11/29/2023
Date

State of Missouri)
County of Jackson)

I, Michael Morrison, state that the above and foregoing is based on my best knowledge and belief.

Subscribed and sworn to before me, a notary public, on this 29th day of November, 2023

My Commission Expires: 2/28/26 *Callie Grace Starks*
Notary Public

STAMP:

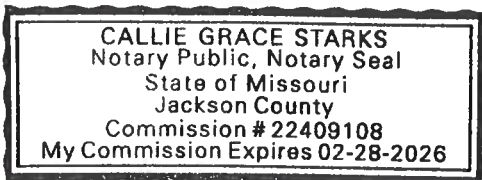

Tenoch Construction, Inc.
912 Scott Avenue
Kansas City, KS 66105

MWDBE SUBCONTRACTOR BUSINESS NAME: _____

Sonya Segura Ilich
Signature: Subcontractor
President
Title

Sonya Segura Ilich
Print Name
11/29/23
Date

State of Kansas)
County of Wyandotte)

I, Kurt D. Bowers, state that the above and foregoing is based on my best knowledge and belief.

Subscribed and sworn to before me, a notary public, on this 29th day of Nov, 2023

My Commission Expires: 08/24/2024 *K D Bowers*
Notary Public

STAMP:

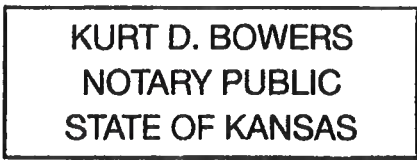



LETTER OF INTENT TO SUBCONTRACT

Check one:	
Original LOI:	<input checked="" type="checkbox"/>
Updated LOI:	<input type="checkbox"/>

Project Name/Title WD Asphalt & Concrete, City Wide

Project Location/Number 60XX0028/9835

PART 1: Prime Contractor Superior Bowen Asphalt Co, LLC agrees to enter into a contractual agreement with M/W/DBE Subcontractor Streetwise, Inc who will provide the following goods/services in connection with the above-reference contract: [Insert a brief narrative describing goods/services to be provided. Broad Categorizations (e.g., "electrical," "plumbing," etc.) or the listing of NAICS Codes in which M/W/DBE Subcontractor is certified are insufficient and may result in denial of this Letter of Intent to Subcontract.]
Traffic control and pavement marking

for an estimated amount of \$ 74,003 (or 1 % of the total estimated contract value.)

- M/WBE Vendor type:
- Subcontractor/manufacturer (counts as 100% of contract value towards goals)
 - Supplier (counts as 60% of the total dollar amount paid or to be paid by a prime contractor for supplies or goods towards goals)
 - Broker (counts as 10% of the total dollar amount paid or to be paid by a prime contractor for supplies or goods towards goals)

M/W/DBE Subcontractor is, to the best of Prime Contractor's knowledge, currently certified with the City of Kansas City's Civil Rights & Equal Opportunity Department to perform in the capacities indicated herein. Prime Contractor agrees to utilize M/W/DBE Subcontractor in the capacities indicated herein, and M/W/DBE Subcontractor agrees to work on the above-referenced contract in the capacities indicated herein, contingent upon award of the contract to Prime Contractor.

PART 2: This section is to be completed by the M/W/DBE subcontractor listed above. Please attach additional sheets as needed for more than one intended sub-tier contract. **IMPORTANT: Falsification of this document will result in denial and other remedies available under City Code.**

- Select one:
- The M/W/DBE Subcontractor listed above **IS NOT** subcontracting any portions of the above-stated scope of work(s). (Continue to Part 3.)
 - The M/W/DBE Subcontractor listed above **IS** subcontracting certain portions of the above stated scope of work(s) to:

(1) Company name: _____

Full address: _____
Street number and name City, State and Zip Code

Primary contact: _____
Name Phone

a) This subcontractor is (select one): MBE WBE DBE N/A

i: If this subcontractor is an M/W/DBE certified with the City of Kansas City, Missouri, a separate Letter of Intent must be attached to this document.

ii. If this subcontractor is NOT a certified M/W/DBE certified with the City of Kansas City, Missouri, the firm must still be listed for reporting purposes but a Letter of Intent is not required.

b) Scope of work to be performed: _____

c) The dollar value of this agreement is: _____



PART 3:

**NOTE: SIGNATURES AND NOTARIZATIONS REQUIRED FOR NEW LETTERS OF INTENT (LOI);
SIGNATURES ONLY FOR UPDATED LOI (ADDING VALUE TO EXISTING CONTRACT).**

PRIME CONTRACTOR BUSINESS NAME: Superior Bowen Asphalt Co, LLC

[Signature]
Signature: Prime Contractor
Estimator
Title

Michael Morrison
Print Name
11/29/2023
Date

State of Missouri)
County of Jackson)

I, Michael Morrison, state that the above and foregoing is based on my best knowledge and belief.

Subscribed and sworn to before me, a notary public, on this 29 day of Nov, 20 23

My Commission Expires: 2/28/26 Callie Grace Starks
Notary Public

STAMP:

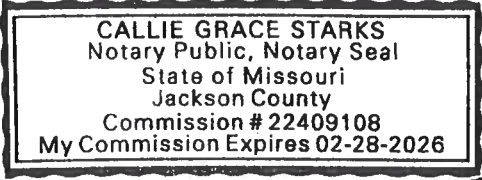

MWDBE SUBCONTRACTOR BUSINESS NAME: Streetwise, Inc.

[Signature]
Signature: Subcontractor
Vice President
Title

Ryan Lee
Print Name
11/29/2023
Date

State of Missouri)
County of Jackson)

I, Courtney Bratkov, state that the above and foregoing is based on my best knowledge and belief.

Subscribed and sworn to before me, a notary public, on this day of 29th, 20 23

My Commission Expires: 2/17/2024 [Signature]
Notary Public

STAMP:

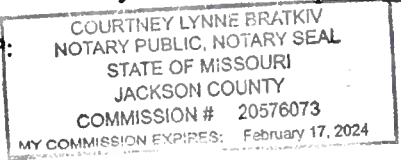



LETTER OF INTENT TO SUBCONTRACT

Check one:	
Original LOI:	<input checked="" type="checkbox"/>
Updated LOI:	<input type="checkbox"/>

Project Name/Title WD Asphalt & Concrete, City Wide

Project Location/Number 60XX0028/9835

PART 1: Prime Contractor Superior Bowen Asphalt Co, LLC agrees to enter into a contractual agreement with M/W/DBE Subcontractor Tenoch Construction, Inc who will provide the following goods/services in connection with the above-reference contract: [Insert a brief narrative describing goods/services to be provided. Broad Categorizations (e.g., "electrical," "plumbing," etc.) or the listing of NAICS Codes in which M/W/DBE Subcontractor is certified are insufficient and may result in denial of this Letter of Intent to Subcontract.]
Curb and driveway approaches

for an estimated amount of \$ 740,027 (or 10 % of the total estimated contract value.)

- M/WBE Vendor type:
- Subcontractor/manufacturer (counts as 100% of contract value towards goals)
 - Supplier (counts as 60% of the total dollar amount paid or to be paid by a prime contractor for supplies or goods towards goals)
 - Broker (counts as 10% of the total dollar amount paid or to be paid by a prime contractor for supplies or goods towards goals)

M/W/DBE Subcontractor is, to the best of Prime Contractor's knowledge, currently certified with the City of Kansas City's Civil Rights & Equal Opportunity Department to perform in the capacities indicated herein. Prime Contractor agrees to utilize M/W/DBE Subcontractor in the capacities indicated herein, and M/W/DBE Subcontractor agrees to work on the above-referenced contract in the capacities indicated herein, contingent upon award of the contract to Prime Contractor.

PART 2: This section is to be completed by the M/W/DBE subcontractor listed above. Please attach additional sheets as needed for more than one intended sub-tier contract. **IMPORTANT: Falsification of this document will result in denial and other remedies available under City Code.**

- Select one:
- The M/W/DBE Subcontractor listed above **IS NOT** subcontracting any portions of the above-stated scope of work(s). (Continue to Part 3.)
 - The M/W/DBE Subcontractor listed above **IS** subcontracting certain portions of the above stated scope of work(s) to:

(1) Company name: _____

Full address: _____

Street number and name City, State and Zip Code

Primary contact: _____

Name Phone

a) This subcontractor is (select one): MBE WBE DBE N/A

i: If this subcontractor is an M/W/DBE certified with the City of Kansas City, Missouri, a separate Letter of Intent must be attached to this document.

ii. If this subcontractor is NOT a certified M/W/DBE certified with the City of Kansas City, Missouri, the firm must still be listed for reporting purposes but a Letter of Intent is not required.

b) Scope of work to be performed: _____

c) The dollar value of this agreement is: _____

PART 3:

**NOTE: SIGNATURES AND NOTARIZATIONS REQUIRED FOR NEW LETTERS OF INTENT (LOI);
SIGNATURES ONLY FOR UPDATED LOI (ADDING VALUE TO EXISTING CONTRACT).**

PRIME CONTRACTOR BUSINESS NAME: Superior Bowen Asphalt Co, LLC

[Signature]
Signature: Prime Contractor
Estimator
Title

Michael Morrison
Print Name
11/29/2023
Date

State of Missouri)

County of Jackson)

I, Michael Morrison, state that the above and foregoing is based on my best knowledge and belief.

Subscribed and sworn to before me, a notary public, on this 29th day of November, 2023

My Commission Expires: 2/28/26 Callie Grace Starks
Notary Public

STAMP:

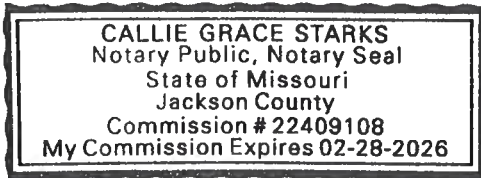

Tenoch Construction, Inc.
912 Scott Avenue
Kansas City, KS 66105

MWDBE SUBCONTRACTOR BUSINESS NAME: _____

Sonya Segura Ulrich
Signature: Subcontractor
President
Title

Sonya Segura Ulrich
Print Name
11/29/23
Date

State of Kansas)

County of Wyandotte)

I, Kurt D. Bowers, state that the above and foregoing is based on my best knowledge and belief.

Subscribed and sworn to before me, a notary public, on this 29th day of Nov, 2023

My Commission Expires: 08/24/2024 Kurt D Bowers
Notary Public

STAMP:

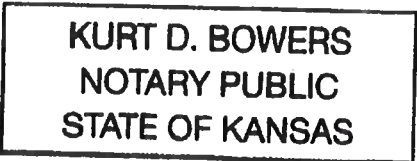

TIMETABLE FOR MBE/WBE UTILIZATION

(This form should be submitted to the City after contract award.)

I, _____, acting in my capacity as _____
(Name) (Position with Firm)
of _____, with the submittal of this Timetable, certify that
(Name of Firm)
the following timetable for MBE/WBE utilization in the fulfillment of this contract is correct and true to the best of my knowledge.

ALLOTTED TIME FOR THE COMPLETION OF THIS CONTRACT

(Check one only)

15 days	___	75 days	___	135 days	___
30 days	___	90 days	___	150 days	___
45 days	___	105 days	___	165 days	___
60 days	___	120 days	___	180 days	___
Other	_____ (Specify)				

Throughout _____ Beginning 1/3 _____
Middle 1/3 _____ Final 1/3 _____
Beginning 1/3 _____% Middle 1/3 _____% Final 1/3 _____%

PLEASE NOTE: Any changes in this timetable require approval of the Civil Rights & Equal Opportunity Department in advance of the change.

If you have any questions regarding the completion of this form, please contact the Civil Rights & Equal Opportunity Department at: (816) 513-1836.

Michael J. Morrison

(Signature)

(Position with Firm)

(Date)



Contractor Utilization Plan Approval Form

Prepared by: Leona Walton

e-Builder users: Approval Form must be completed and attached in PDF format where indicated. CUP/LOIs must be attached where indicated, or as supporting documents.

Date: 11/30/23

Contract/Project Number: 9835 / 60XX0028	Project Name: WD Asphalt and Concrete, City Wide
Developer/Prime: Superior Bowen Asphalt Co., LLC	Contact Name: Mike Morrison
Address: 520 W. Pennway, KCMO 64108	Email: mmorrison@superiorbowen.com

Full Contract Value: \$ 7,500,000.00

Funding: City State Federal CO-OP Grant: Other:

Project Requirements: M/WBE DBE Section 3 N/A

Tax Incentive: LCRA TIF PIEA N/A Other:

Prevailing Wage: Yes No

Davis-Bacon: Yes No

Construction Employment Program: Yes: Workforce goals are 10% Minority & 2% Women. There are over 800 Workforce hours and project cost is \$300,000 or more.
 NO: Workforce hours are less than 800 and project cost is less than \$300,000.

Contract Goals:	Contractor Utilization Plan Achievement:
Self-Perform: <u> yes </u> %	Self-Perform: <u> yes </u> %
MBE: <u> 10 </u> %	MBE: <u> 11 </u> %
WBE: <u> 10 </u> %	WBE: <u> 11 </u> %
Non-certified firms: <u> yes </u> %	Non-certified firms: <u> yes </u> %

Contract Type (select one): Construction Design-Build Design Professional Professional Services
 General Services Facilities Maintenance/Repair/Renovation Concessions Co-operative
 Revenue Sharing Non-Municipal Agency Other Goods & Services Other _____

Project Manager: Todd Rohr Email: Todd.Rohr@kcmo.org
 Additional Information:

This document is submitted with all available facts. Intentionally falsifying this document or omitting pertinent facts is grounds for disciplinary action pursuant to KCMO Human Resources Rules & Policy Manual (eff. August 4, 2014).

FOR CIVIL RIGHTS & EQUAL OPPORTUNITY DEPARTMENT (CREO) USE ONLY:

The Contractor Utilization Plan is:

Approved Disapproved

 10 % MBE 10 % WBE % DBE

The Request for Good Faith Efforts Waiver is:

Approved Disapproved Not Applicable

Appeal Sent to FICB or Incentive Agency? Yes FICB Incentive Agency No

CREO Signature: Mark Runge Date: 12/12/2023

Comments:



**Civil Rights & Equal Opportunity Department
Economic Equity & Inclusion
Nondiscrimination & Equal Opportunity Review Form**

Date: 11/30/2023
Form Prepared By: Leona Walton

Contract/Project Number: 9835 / 60XX0028	Project Name: WD Asphalt and Concrete, City Wide
Developer/Prime: Superior Bowen Asphalt Co., LLC	Contact Information: Mike Morrison/morrison@superiorbowen.com/816-921-8200
Final Contract Value: \$ 7,500,000.00	Project Manager: Todd Rohr/Todd.Rohr@kcmo.org/816-513-0323

Funding: City State Federal CO-OP Grant: Other:

Project Requirements: M/WBE DBE Section 3 N/A

Tax Incentive: LCRA TIF PIEA Ch. 100 Other: N/A

Prevailing Wage: Yes No

Davis-Bacon: Yes No

Construction Employment Program: Yes: Workforce goals are 10% Minority & 2% Women. There are over 800 Workforce hours and project cost is \$300,000 or more.
 No: Workforce hours are less than 800 and project cost is less than \$300,000.

Contracts & Leases	Nondiscrimination
Ch. 3 Article IV: <u>yes</u>	Ch. 38: <u>yes</u>
RSMo 213: <u>yes</u>	Title VI: <u>yes</u>
MWDBE: <u>yes</u>	Prevailing Wage and Labor Standards: <u>yes</u>
SLBE: <u>n/a</u>	RSMo 34 Anti-Discrimination Against Israel: <u>yes</u>

Contract Type:

Construction Design-Build Design Professional Professional Services

General Service Concession Other Goods & Services Non-Municipal Agency

Co-Operative Revenue Sharing Facilities Maintenance/Repair/Renovation

Other:

Additional Information:

This document is submitted with all available facts. Intentionally falsifying this document or omitting pertinent facts is grounds for disciplinary action pursuant to KCMO Human Resources Rules & Policy Manual (eff. August 4, 2014).

FOR CIVIL RIGHTS & EQUAL OPPORTUNITY DEPARTMENT (CREO) USE ONLY:

The Document is:

Approved Disapproved

Changes Needed:

Federal Provisions Included:

Approved Disapproved Not Applicable

CREO Signature: Mark Runge Date: 12/12/2023

DocuSigned by: 6AFEC964B0364TA...

Comments: CREO Assurances to be attached to contract.



Civil Rights and Equal Opportunity Department Civil Rights and Wage Assurances

Non-discrimination in Employment. Contractor shall not discriminate against any employee or candidate for employment on the basis of an individual's race, hair texture or hair style associated with an individual's race, color, sex, religion, national origin, or ancestry, disability, sexual orientation, gender identity, age, or in any other manner prohibited by Chapter 38 of the City Code. Contractor shall not engage in any discrimination as prohibited by Chapter 3 of the City Code.

Ban the Box in Hiring and Promotion.

(a) Pursuant to Section 38-104, City Code Ordinances, Contractor shall not base a hiring or promotional decision on an applicant's criminal history or sentence related thereto, unless the employer can demonstrate that the employment-related decision was based on all information available including consideration of the frequency, recentness and severity of a criminal record and that the record was reasonably related to the duties and responsibilities of the position.

(b) Notwithstanding subsection (a), Contractor may inquire about an applicant's criminal history after it has been determined that the individual is otherwise qualified for the position, and only after the applicant has been interviewed for the position. Any such inquiry may be made of all applicants who are within the final selection pool of candidates from which a job will be filled.

(c) This provision shall not apply to positions where employers are required to exclude applicants with certain criminal convictions from employment due to local, state or federal law or regulation.

Title VI of the Civil Rights Act of 1964. Title VI of the Civil Rights Act of 1964 requires that no person in the United States shall, on the grounds of race, color, or national or origin (including limited English proficient individuals), be excluded from participation in, be denied the benefits of, or be subjected to discrimination under any program or activity receiving federal financial assistance. The City of Kansas City, Missouri requires compliance with the requirements of Title VI in all of its programs and activities regardless of the funding source.

Contractor shall not discriminate on the grounds of race, color, or national or origin (including limited English proficient individuals).

Quality Services Assurance Act. If this Contract exceeds \$160,000.00, Contractor certifies Contractor will pay all employees who will work on this Contract in the city limits of Kansas City, Missouri at least \$15.00 per hour in compliance with the City's Quality Services Assurance Act,



Civil Rights and Equal Opportunity Department Civil Rights and Wage Assurances

Section 3-66, Code of Ordinances or City has granted Contractor an exemption pursuant to the Quality Services Assurance Act.

Anti-Discrimination Against Israel. If this Contract exceeds \$100,000.00 and Contractor employs at least ten employees, pursuant to Section 34.600, RSMo., by executing this Contract, Contractor certifies it is not currently engaged in and shall not, for the duration of this contract, engage in a boycott of goods or services from the State of Israel; companies doing business in or with Israel or authorized by, licensed by, or organized under the laws of the State of Israel; or persons or entities doing business in the State of Israel.

Affirmative Action. If this Contract exceeds \$300,000.00 and Contractor employs fifty (50) or more people, Contractor shall comply with City's Affirmative Action requirements in accordance with the provisions of Chapter 3 of City's Code, the rules and regulations relating to those sections, and any additions or amendments thereto; in executing any Contract subject to said provisions, Contractor warrants that it has an affirmative action program in place and will maintain the affirmative action program in place for the duration of the Contract. Contractor shall not discriminate against any employee or applicant for employment because of race, color, sex, religion, national origin or ancestry, disability, sexual orientation, gender identity or age in a manner prohibited by Chapter 3 of City's Code. Contractor shall:

- (a) Execute and submit the City of Kansas City, Missouri CREO Affirmative Action Program Affidavit warranting that the Contractor has an affirmative action program in place and will maintain the affirmative action program in place for the duration of the Contract.
- (b) Submit, in print or electronic format, a copy of Contractor's current certificate of compliance to the City's Civil Rights and Equal Opportunity Department (CREO) prior to receiving the first payment under the Contract, unless a copy has already been submitted to CREO at any point within the previous two (2) calendar years. If, and only if, Contractor does not possess a current certification of compliance, Contractor shall submit, in print or electronic format, a copy of its affirmative action program to CREO prior to receiving the first payment under the Contract, unless a copy has already been submitted to CREO at any point within the previous two (2) calendar years.
- (c) Require any Subcontractor awarded a subcontract exceeding \$300,000.00 to affirm that Subcontractor has an affirmative action program in place and will maintain the affirmative action program in place for the duration of the subcontract.
- (d) Obtain from any Subcontractor awarded a subcontract exceeding \$300,000.00 a copy of the Subcontractor's current certificate of compliance and tender a copy of the same, in print or

Civil Rights and Equal Opportunity Department Civil Rights and Wage Assurances

electronic format, to CREO within thirty (30) days from the date the subcontract is executed. If, and only if, Subcontractor does not possess a current certificate of compliance, Contractor shall obtain a copy of the Subcontractor's affirmative action program and tender a copy of the same, in print or electronic format, to CREO within thirty (30) days from the date the subcontract is executed.

City has the right to take action as directed by City's Civil Rights and Equal Opportunity Department to enforce this provision. If Contractor fails, refuses or neglects to comply with the provisions of Chapter 3 of City's Code, then such failure shall be deemed a total breach of this Contract and this Contract may be terminated, cancelled or suspended, in whole or in part, and Contractor may be declared ineligible for any further contracts funded by City for a period of one (1) year. This is a material term of this Contract.

Compliance with Laws. Contractor shall comply with all federal, state and local laws, ordinances and regulations applicable to the work and this Agreement. Contractor shall maintain in effect all the licenses, permissions, authorizations, consents and permits that it needs to carry out its obligations under this Agreement.

Prevailing Wage. If the Agreement exceeds \$75,000.00 and any of the Services performed by Contractor includes construction, reconstruction, improvement, enlargement, alteration, painting and decorating, or major repair, that is subject to the Missouri Prevailing Wage Law (Section 290.210, RSMo – 290.340, RSMo), Contractor shall immediately notify the City prior to performing Services so the parties can execute an agreement that incorporates, the appropriate Wage Order. Contractor shall comply with all requirements of Section 290.210, RSMo – 290.340, RSMo even if Contractor fails to notify the City.

Civil Rights & Equal Opportunity Department
Economic Equity & Inclusion
Request for Modification/Substitution Approval Form

Date: 10/8/2024
 Form Prepared By: Matt Bowen

Contract/Project Number: 60XX00028/9835	Project Name: WD Asphalt and Concrete
---	---------------------------------------

Owning Department: KCWater	Project Manager: Todd Rohr
----------------------------	----------------------------

Funding: City State Federal CO-OP Grant: Other:
 Project Requirements: M/WBE DBE Section 3 N/A
 Tax Incentive: LCRA TIF PIEA N/A Other:

Developer/Prime: Superior Bowen Asphalt CO	Address: 520 W Pennway St
Contact: Matt Bowen	Phone: 8169184445
Contact Email: matt@superiorbowen.com	Fax: N/A

Contract Type:

Construction Design-Build Design Professional Professional Services
 General Service Concession Other Goods & Services Non-Municipal Agency
 Co-Operative Revenue Sharing Facilities Maintenance/Repair/Renovation
 Other:

Reason for Modification/Substitution Request:
 The scope of work for this project consists of on-call repairs to infrastructure that is damaged during water main breaks. Therefore, the types of work that are going to be needed are unknown until the water main breaks occur. Through the first half of this contract, the work that has been needed has not leant itself as much to the M/WBE contractors in our utilization plan. In order to make a good faith effort to meet the goals, we have added two additional M/WBE subcontractors to our utilization plan. Due to the emergency nature of this contract and the

CONTRACT SUMMARY*	
Original Contract Maximum Obligation:	\$ 7,500,000.00
Amendment/Change Order No. 1:	\$
Amendment/Change Order No. 2:	\$
Amendment/Change Order No. 3:	\$
Amendment/Change Order No. 4:	\$
Amendment/Change Order No. 5:	\$
Current Maximum Obligation:	\$
Proposed Amendment/Change Order No.	\$
Proposed Revised Contract Maximum Obligation:	\$ 7,500,000.00

This document is submitted with all available facts. Intentionally falsifying this document or omitting pertinent facts is grounds for disciplinary action pursuant to KCMO Human Resources Rules & Policy Manual (eff. August 4, 2014).

FOR CIVIL RIGHTS & EQUAL OPPORTUNITY DEPARTMENT (CREO) USE ONLY:		
The Request for Modification/Substitution is:		
<input checked="" type="checkbox"/> Approved	<input type="checkbox"/> Disapproved	
<u>6</u> % MBE	<u>6</u> % WBE	<u> </u> % DBE
The Request for Good Faith Efforts Waiver is:		
<input type="checkbox"/> Approved	<input type="checkbox"/> Disapproved	<input checked="" type="checkbox"/> Not Applicable
RFM/S Affidavit Attached?	<input checked="" type="checkbox"/> Yes	<input type="checkbox"/> No

DocuSigned by:
 CREO Signature: Rebecca Amerzawa-Hogan Date: 10/23/2024
 1C5032A12EB3471...

*The CONTRACT SUMMARY information should match information and calculations gathered and computed on the Contract Amendment or Change Order Preparation Checklist. The Checklist forms are found on Contract Central.



TIMETABLE FOR MBE/WBE UTILIZATION

(This form should be submitted to the City after contract award.)

I, _____, acting in my capacity as _____
 (Name) (Position with Firm)
 of _____, with the submittal of this Timetable, certify that
 (Name of Firm)
 the following timetable for MBE/WBE utilization in the fulfillment of this contract is correct and true to the best of my knowledge.

ALLOTTED TIME FOR THE COMPLETION OF THIS CONTRACT

(Check one only)

15 days	_____	75 days	_____	135 days	_____
30 days	_____	90 days	_____	150 days	_____
45 days	_____	105 days	_____	165 days	_____
60 days	_____	120 days	_____	180 days	_____
Other	_____ (Specify)				

Throughout	_____	Beginning 1/3	_____
Middle 1/3	_____	Final 1/3	_____
Beginning 1/3	_____ %	Middle 1/3	_____ %
		Final 1/3	_____ %

PLEASE NOTE: Any changes in this timetable require approval of the Civil Rights & Equal Opportunity Department in advance of the change.

If you have any questions regarding the completion of this form, please contact the Civil Rights & Equal Opportunity Department at: (816) 513-1836.

Michael J. Morrison

(Signature)

 (Position with Firm)

 (Date)





REQUEST FOR MODIFICATION OR SUBSTITUTION

(This Form must be submitted to CREO KC to request substitutions for an MBE/WBE listed in the Contractor Utilization Plan or for modification of the amount of MBE/WBE participation listed in the Contractor Utilization Plan. This Form shall be an amendment to the Contractor Utilization Plan.)

BIDDER/PROPOSER/CONTRACTOR: Superior Rowan Asphalt Co.
ADDRESS: 520 W. Pennway St. Suite 300 Kansas 64108
PROJECT NUMBER OR TITLE: 60xx0028/9835 Asphalt & Concrete Restoration
AMENDMENT/CHANGE ORDER NO: (if applicable) _____

Project Goals: 10 original goal % MBE 10 % WBE
Contractor Utilization Plan: 10 % MBE 10 % WBE

1. I am the duly authorized representative of the above Bidder/Contractor/Proposer and am authorized to request this substitution or modification on behalf of the Bidder/Contractor/Proposer.

2. I hereby request that the Director of CREO KC recommend or approve: (check appropriate space(s))

a. A substitution of the certified MBE/WBE firm _____, (Name of new firm)
to perform _____, (Scope of work to be performed by new firm)
for the MBE/WBE firm _____ which is currently (Name of old firm)
listed on the Bidder's/Contractor's/Proposer's Contractor Utilization Plan to
perform the following scope of work: _____ (Scope of work of old firm)

b. A modification of the amount of MBE/WBE participation currently listed on the Bidder's/Contractor's/Proposer's Contractor Utilization Plan from
10 % MBE 10 % WBE (Fill in % of MBE/WBE Participation currently listed on Contractor Utilization Plan)

TO

6 % MBE 6 % WBE (Fill in New % of MBE/WBE Participation requested for Contractor Utilization Plan)

- c. Attach 00450.01 Letter of Intent to Subcontract letter for each new MBE/WBE to be added.
- d. Attach a copy of the most recent 00485.01 or on-line M/WBE Monthly Utilization Report

3. Bidder/Contractor/Proposer states that a substitution or modification is necessary because: (check applicable reason(s))



- The MBE/WBE listed on the Contractor Utilization Plan is non-responsive or cannot perform.
- The MBE/WBE listed on the Contractor Utilization Plan has increased its previously quoted price without a corresponding change in the scope of work.
- The MBE/WBE listed on the Contractor Utilization Plan has committed a material default or breach of its contract.
- Requirements of the scope of work of the contract have changed and make subcontracting not feasible or not feasible at the levels required by the goals established for the contract.
- The MBE/WBE listed on the Contractor Utilization Plan is unacceptable to the City contracting department.
- Bidder/Contractor/Proposer has not attempted intentionally to evade the requirements of the Act and it is in the best interests of the City to allow a modification or substitution.

4. The following is a narrative summary of the Bidder's/Contractor's/Proposer's good faith efforts exhausted in attempts to substitute the MBE/WBE firm named above which is currently listed on the Contractor Utilization Plan with other qualified, certified MBE/WBE firms for the listed scope of work or any other scope of work in the project:

See attached

5. Bidder/Proposer/Contractor will present documentation when requested by the City to evidence its good faith efforts.

Dated: 7/23/2024

Superior-Bowen Asphalt
(Bidder/Proposer/Contractor)

[Signature]
By: (Authorized Representative)



4. The scope of work for this project consists of on-call repairs to infrastructure that is damaged during water main breaks. Therefore, the types of work that are going to be needed are unknown until the water main breaks occur. Through the first half of this contract, the work that has been needed has not leant itself as much to the M/WBE contractors in our utilization plan. In order to make a good faith effort to meet the goals, we have added two additional M/WBE subcontractors to our utilization plan. Due to the emergency nature of this contract and the timeliness with which it is required to make repairs, it is not a good fit for very many subcontractors, and therefore the options for utilizing other subcontractors is very limited. We will continue to look for additional opportunities to add M/WBE subcontractors to our plan, as well us additional utilization for our current subcontractors.

Compliance Audit: June 2024

[Contract Main](#)
[View Contract](#)
[Subcontractors](#)
[Compliance Audit List](#)
[Compliance Audit Summary](#)
[Messages](#)
[Comments](#)
[Reports](#)
[Workforce Audit List](#)

Workforce Audit Summary

City of Kansas City
 WSD9835 / 60XX0028: WD Asphalt and Concrete, City Wide
 Prime: Superior Bowen Asphalt Co

Status: Open
 11/30/2023 - 11/30/2025
 Current Value: \$7,500,000

Listed are subcontractors assigned to this contract. Click the links to the right of the vendor's name to submit or edit a response. You must submit data on each subcontractor to complete the audit.

Compliance Audit Information

COMPLIANCE AUDIT STATUS	Complete
COMPLIANCE AUDIT PERIOD	June 2024
PAYMENT TO PRIME	Payment to prime not reported yet
MARKED AS FINAL AUDIT?	No (mark audit as final)

Compliance Audit Summary - Total Contract Through TODAY (7/18/2024)

	Award	Award Percent	Payments	Payments Percent	Difference (Payments - Award)
Prime Contract	\$7,500,000.00		\$0.00		
For Credit	\$1,500,000.00	20.000%	\$248,292.40	0.000%	
Goal Types					
For Credit to MBE Goal	\$750,000.00	10.000%	\$158,082.20	0.000%	
For Credit to WBE Goal	\$750,000.00	10.000%	\$90,210.20	0.000%	
Contract Progress				0%	
For Credit Progress				17%	

Award values may not match due to differences between overall contract goal and subcontractor assignments.

Mark Remaining Subcontractors as Zero

Mark Audit as Final

Report Error

Subcontractor Payments for June 2024

Subcontractor	Certified	Type	Inc. In Goal	Actions	Paid Amount In June 2024	Confirmed by Sub	Total To June 2024	Contract Goal	Actual Percent
1 <u>Martin T. Rucker Development LLC</u> Martin Rucker mrucker@mruckerdevelopment.com P 816-294-6821, F 816-238-7692		Truck/Haul 100%	MBE	View Edit	\$6,880.30		\$48,356.24	1.333%	0.000%
1 <u>Streetwise, Inc.</u> Shawna Hettinger shettinger@streetwise-inc.com P 816-331-2355, F 816-331-1355		Sub 100%	WBE	View Edit	\$975.00		\$14,349.80	1.000%	0.000%
1 <u>Tenoch Construction, Inc.</u> Sonya Segura-Ulrich sonya@tenochconstruction.com P 913-671-7706, F 913-671-7307		Sub 100%	MBE	View Edit	\$34,765.77		\$109,725.96	10.000%	0.000%
1 <u>Tenoch Construction, Inc.</u> Sonya Segura-Ulrich sonya@tenochconstruction.com P 913-671-7706, F 913-671-7307		Sub 100%	WBE	View Edit	\$13,028.94		\$75,860.40	9.000%	0.000%

Click subcontractor name to view payment history for this contract. Click contact person's name to send them a message.

[Return to Audit Notice](#)

[Customer Support](#)

Copyright © 2024 B2Gnow. All rights reserved.

[Home](#) | [Print This Page](#) | [Print To PDF](#) | [Translate](#)

Powered by B2Gnow

CREO KC MONTHLY REPORTING INSTRUCTIONS

M/WBE Monthly Utilization Report Instructions

1. MBE/WBE Reporting applies to Contracts that have approved MBE/WBE goals assigned.
2. The City will utilize a web-based MBE/WBE Reporting System in the administration of this Contract. This web-based application database is a collaboration tool selected and provided by the City, which will allow Contractors and Consultants/Subcontractors and Subconsultants to enter data and report on compliance.

Prevailing Wage Certified Payroll Report Instructions

1. Prevailing Wage Certified Payroll Report applies to Contracts that include Prevailing Wage or Davis Bacon Provisions.
2. This web-based application database is provided by the City for reporting certified payrolls and other related prevailing wage data.
3. Computer Requirements: Minimum Intel Pentium® 4 Processor 2.4 GHz or equivalent processor with 512MB of RAM; recommended Centrino Duo® Processors 1.6 GHz or equivalent with 2GB of RAM, or higher.
 - a. Computer Operation System: Windows XP, Windows Vista, or Windows 7
 - b. Web Browser: Google Chrome
 - c. Connection Speed/Minimum Bandwidth: DSL, ADSL or T1 Line for transferring a minimum of 3 Mbps Downstream and 512 Kbps Upstream
4. City will assist Contractor in providing training of personnel and Subcontractor's personnel.
5. Contractor and Subcontractors shall have the responsibility for visiting the web site and entering data in on timely basis, and as necessary to be in compliance with Prevailing Wage Requirements included in their contracts.

Workforce Monthly Report Instructions

1. Workforce Monthly Reporting only applies to Construction Contracts greater than \$300,000 and greater than 800 projected labor hours.
2. The City will utilize a web-based Reporting System in the administration of this Contract. This web-based application database is a collaboration tool selected and provided by the City, which will allow Contractors and Subcontractors to enter data and report on Workforce compliance.



M/WBE Monthly Compliance Audit Online Reporting Instructions

PRIME INSTRUCTIONS:

The Prime's responsibility is to report payments made to subcontractors for the prior month.

1. Log into B2GNow Diversity Management System (B2GNow)
2. On the Dashboard, click Contract Audits.
3. Select the specific audit that needs to be completed. Any and all money that changed hands during the month of the audit must be reported to the specific audit month.
4. To complete audit select Report 1 Subcontractor Payment. Under the actions column, select Submit Response for the specific subcontractor that needs reporting or select the Submit ALL Incomplete Records button to go to all the subcontractors to report amounts. Under the audit information answer the following questions:

The screenshot shows a form titled "Audit Information" with a blue header. Below the header, there is a text input field for "Amount PAID for June 2020" with a dollar sign icon and a red asterisk. A red note below it says "Do NOT enter invoice amount." There is also a "Payment Date" field with a red note: "Enter payment date if you made a payment for June 2020" and "If multiple payments were made, enter the date of the first payment." The "Payment Detail" section has a text area with instructions: "Enter details of PAID check numbers (or ACH references) and amounts for June 2020. This information is optional but will speed up the confirmation process. Payment details are displayed to Dan's Contracting Test."

Once information has been entered, select review and save. Complete same steps for all subcontractors. If there were subcontractors that did not receive a payment for the specific audit month, click the Mark Remaining Subcontractors as Zero button to mark remaining subcontractors as 0.

SUBCONTRACTOR INSTRUCTIONS:

The responsibility of the Subcontractor is to confirm payment received for specific audit month.

1. Log in to B2GNow Diversity Management System (B2GNow)
2. On the Dashboard, select Contract Audits.
3. Select the specific audit that needs to be completed.
4. To complete audit, select Confirm Payment Received. There will be two options: correct or incorrect. Select correct if payment was in fact received OR if payment was not received or amount was different select incorrect. Answer all questions and select save to complete.

The screenshot shows a form titled "Compliance Audit Information" with a grey header. It contains several sections: "Amount Reported by the prime contractor for November 2021 as PAID to You" with a value of "\$500.00"; "Confirm Reported Amount?" with radio buttons for "Correct - the amount reported by the prime contractor as PAID to us is correct (\$500.00)." and "Incorrect - the amount reported by the prime contractor as PAID to us is not correct."; "Final Payment?" with radio buttons for "No - our work on this contract continues." (selected), "Yes - this is our last payment for this contract.", and "N/A - we have not begun work on this project or we have not been paid yet for our work."; and "Is Prime Withholding Retainage?" with radio buttons for "No" and "Yes".

NOTE: Complete one M/WBE report per project.

An email notice will be sent from our organization monthly to notify Prime & Subcontractor users of incomplete audits.



Project-Specific Workforce Monthly Report

Human Relations Department - City of Kansas City Missouri

Report Date:	Reporting Period:	Project Description:	
Project Name:	Contractor:	Contract Awarded Date:	
City Project Number:	Contractor Address:	City Contract Number:	
Project Address:		City Vendor ID:	
	Contact Person/Phone:	Contractor Report <input type="checkbox"/>	Subcontractor Report <input type="checkbox"/>
E-mail Address:		Final Cumulative Report:	<input type="checkbox"/> Yes <input type="checkbox"/> No

Report the total monthly hours of work performed by all workers on the City Construction Contract. Enter the total hours on all lines and in all columns. Reported workforce hours should be based on payroll records.

JOB CATEGORIES	OVERALL TOTAL (Sum of all Columns, A thru F Male & Female)	A Total Hours White Employees		B Total Hours Black Employees		C Total Hours Hispanic Employees		D Total Hours Asian/Pacific Islander		E Total Hours Native American Employee		F Total Hours Other/Unknown Race Employee		G KCMO Resident Hours
		M	F	M	F	M	F	M	F	M	F	M	F	Total #
		Foreman/Supervisor												
Asbestos Worker Journeyman														
Asbestos Worker Apprentice														
Boilermaker Journeyman														
Boilermaker Apprentice														
Bricklayer Journeyman														
Bricklayer Apprentice														
Carpenter Journeyman														
Carpenter Apprentice														
Cement Mason Journeyman														
Cement Mason Apprentice														
Electrician Journeyman														
Electrician Apprentice														
Elevator Constructor Journeyman														
Elevator Constructor Apprentice														
Glazier Journeyman														
Glazier Apprentice														
Iron Worker Journeyman														
Iron Worker Apprentice														
Laborer Journeyman														
Laborer Apprentice														
Operating Engineer Journeyman														
Operating Engineer Apprentice														
Painter Journeyman														
Painter Apprentice														
Pipe Fitter/Plumber Journeyman														
Pipe Fitter/Plumber Apprentice														
Plasterer Journeyman														
Plasterer Apprentice														
Roofer Journeyman														
Roofer Apprentice														
Sheet Metal Journeyman														
Sheet Metal Apprentice														
Sprinkler Fitter														
Sprinkler Fitter Apprentice														
Truck Driver Journeyman														
Truck Driver Apprentice														
Welder Journeyman														
Welder Apprentice														
Other														
Monthly Total Hours														-
Total % of Monthly Hrs.														

Contractor shall submit report by the 15th of each month.		Report Submitted By:
Phillip Yelder, Director Human Relations Department		
414 E. 12th Street, 4th Floor	Kansas City, MO 64106	
Phone: 816-513-1836	Email: HRDcontractcompliance@kcmo.org	Date:

Workforce Monthly Report Forms only apply to Construction Contracts greater than \$300,000.00 with greater than 800 projected labor hours.

Workforce Monthly Report Instructions

(Instructions for online reporting)

Completing a Workforce Audit:

To report your workforce hours:

1. Log into B2GNow Diversity Management System (B2GNow)
2. Click on the red underlined number of 'Incomplete audits' under Workforce Audits
3. Click View for the incomplete audit that needs to be completed.
4. Click Fill in Audit
5. Complete the form including the Payroll Number. Select Add to Audit to report hours worked for specific Craft/Trade.

* required entry

Summary Information	
CONTRACTOR	KCMO Test Vendor Sample
PAYROLL START DATE	11/1/2021
PAYROLL END DATE	11/30/2021
PAYROLL NUMBER	<input style="width: 100%;" type="text"/>
SPECIAL STATUS	<input type="checkbox"/> No Work (all fields will be filled with zeros) <input type="checkbox"/> Suspended <input type="checkbox"/> Final

Enter values below as hours worked. There is no need to fill in zeros; all blank fields will be saved as zero.

Craft/Trade List														
Craft/Trade	Caucasian		Black/African American		Hispanic/Latino		Asian		Native American		Other/Unknown Ethnicity		Local Resident	Comments
	Male	Female	Male	Female	Male	Female	Male	Female	Male	Female	Male	Female		
Foreman/Supervisor														Not included in audit Add to Audit
Asbestos Worker (Journeyman)														Not included in audit Add to Audit

6. Scroll down and select review once hours have been reported.
7. Save and Certify to submit OR Save but Certify Later (to save a draft of your audit response). Audit must be certified for the workforce audit to be submitted for review. If there is an audit where no work was performed, and have 0 hours to report, select the Mark as No Work Audit button on step 4 to report 0 hours for all your employees. Select Certify & Release to Organization to complete. Mark Final for Special Status if the audit being completed is the last month of work, this will notify the system to stop generating monthly audits.

NOTE: If subcontractor has completed Workforce Audit, Prime MUST either accept audit and release to the organization or reject audit back to Subcontractor for correction.

An email notice will be sent from our organization monthly to notify Prime & Subcontractor users of incomplete audits.



Company-Wide Workforce Monthly Report

Human Relations Department - City of Kansas City, Missouri

Report Date:	Reporting Period:	Contract Awarded Date:	
Contractor:		City Vendor ID:	
Contact Person/Phone:	Contractor Address:	Contractor Report <input type="checkbox"/>	Subcontractor Report <input type="checkbox"/>
E-mail Address:	Have you hired any new construction workers this month?	<input type="checkbox"/> Yes <input type="checkbox"/> No	Final Cumulative Report: <input type="checkbox"/> Yes <input type="checkbox"/> No

Report total of all hours of work performed company-wide on all projects in the KCMO Metropolitan Statistical Area (MSA). Enter the total hours on all lines and in all columns. Workforce hours should be based on payroll records.

JOB CATEGORIES	OVERALL TOTAL (Sum of all Columns, A thru F Male & Female)	A Total Hours White Employees		B Total Hours Black Employees		C Total Hours Hispanic Employees		D Total Hours Asian/Pacific Islander		E Total Hours Native American Employee		F Total Hours Other/Unknown Race Employee		G KCMO Resident Hours Total #
		M	F	M	F	M	F	M	F	M	F	M	F	
Foreman/Supervisor														
Asbestos Worker Journeyman														
Asbestos Worker Apprentice														
Boilermaker Journeyman														
Boilermaker Apprentice														
Bricklayer Journeyman														
Bricklayer Apprentice														
Carpenter Journeyman														
Carpenter Apprentice														
Cement Mason Journeyman														
Cement Mason Apprentice														
Electrician Journeyman														
Electrician Apprentice														
Elevator Constructor Journeyman														
Elevator Constructor Apprentice														
Glazier Journeyman														
Glazier Apprentice														
Iron Worker Journeyman														
Iron Worker Apprentice														
Laborer Journeyman														
Laborer Apprentice														
Operating Engineer Journeyman														
Operating Engineer Apprentice														
Painter Journeyman														
Painter Apprentice														
Pipe Fitter/Plumber Journeyman														
Pipe Fitter/Plumber Apprentice														
Plasterer Journeyman														
Plasterer Apprentice														
Roofer Journeyman														
Roofer Apprentice														
Sheet Metal Journeyman														
Sheet Metal Apprentice														
Sprinkler Fitter														
Sprinkler Fitter Apprentice														
Truck Driver Journeyman														
Truck Driver Apprentice														
Welder Journeyman														
Welder Apprentice														
Other														
Total Monthly Hours														
Total % of Hours														

Contractor shall submit report by the 15th of each month.

Phillip Yelder, Director Human Relations Department 414 E. 12th Street, 4th Floor, Kansas City, MO 64106 Phone: 816-513-1836 Email: HRDcontractcompliance@kcmo.org	Report Submitted By: _____ Date: _____
--	---

**Civil Rights & Equal Opportunity Department
Economic Equity & Inclusion
Contract Closeout Approval Form**

Date:
Form Prepared By:

Contract/Project Number:	Project Name:
--------------------------	---------------

Owning Department:	Project Manager:
--------------------	------------------

Funding:	<input type="checkbox"/> City	<input type="checkbox"/> State	<input type="checkbox"/> Federal	<input type="checkbox"/> CO-OP	<input type="checkbox"/> Grant:	Other:
Project Requirements:	<input type="checkbox"/> M/WBE	<input type="checkbox"/> DBE	<input type="checkbox"/> SLBE	<input type="checkbox"/> Section 3	<input type="checkbox"/> N/A	
Tax Incentive:	<input type="checkbox"/> LCRA	<input type="checkbox"/> TIF	<input type="checkbox"/> PIEA	<input type="checkbox"/> N/A	<input type="checkbox"/> Other:	
Prevailing Wage:	<input type="checkbox"/> Yes	<input type="checkbox"/> No				
Davis-Bacon:	<input type="checkbox"/> Yes	<input type="checkbox"/> No				
Construction Employment Program:	<input type="checkbox"/> Yes: Workforce goals are 10% Minority & 2% Women. There are over 800 Workforce hours and project cost is \$300,000 or more.					
	<input type="checkbox"/> NO: Workforce hours are less than 800 and project cost is less than \$300,000.					

Developer/Prime:	Address:
------------------	----------

Contract Type:			
<input type="checkbox"/> Construction	<input type="checkbox"/> Design-Build	<input type="checkbox"/> Design Professional	<input type="checkbox"/> Professional Services
<input type="checkbox"/> General Service	<input type="checkbox"/> Concession	<input type="checkbox"/> Other Goods & Services	<input type="checkbox"/> Non-Municipal Agency
<input type="checkbox"/> Co-Operative	<input type="checkbox"/> Revenue Sharing	<input type="checkbox"/> Facilities Maintenance/Repair/Renovation	
<input type="checkbox"/> Other:			

This document is submitted with all available facts. Intentionally falsifying this document or omitting pertinent facts is grounds for disciplinary action pursuant to KCMO Human Resources Rules & Policy Manual (eff. August 4, 2014).

FOR CIVIL RIGHTS & EQUAL OPPORTUNITY DEPARTMENT (CREO) USE ONLY:

Economic Equity & Inclusion Goals:		
<input type="checkbox"/> Approved	<input type="checkbox"/> LD's/Penalties Assessed \$	<input type="checkbox"/> Not Applicable
Electronic Record?	<input type="checkbox"/> Yes	<input type="checkbox"/> No

Economic Equity & Inclusion Division Signature: _____ Date: _____

Prevailing Wage:		
<input type="checkbox"/> Approved	<input type="checkbox"/> LD's/Penalties Assessed \$	<input type="checkbox"/> Not Applicable
Electronic Record?	<input type="checkbox"/> Yes	<input type="checkbox"/> No

Contract & Labor Standards Division Signature: _____ Date: _____

Workforce Program:		
<input type="checkbox"/> Approved	<input type="checkbox"/> LD's/Penalties Assessed \$	<input type="checkbox"/> Not Applicable
Electronic Record?	<input type="checkbox"/> Yes	<input type="checkbox"/> No
Public Commendation Recommended:	<input type="checkbox"/> Yes	<input type="checkbox"/> No

Contract & Labor Standards Division Signature: _____ Date: _____

Additional Comments:





CONTRACT REQUIRED SUBMISSIONS

Project/Contract Numbers 60XX0028/9835

Project/Contract Title/Description WD Asphalt and Concrete, City Wide

These instructions are to assist Contractor in providing all necessary documents to enter into a contract with the City.

MISSOURI SECRETARY OF STATE BUSINESS ENTITY REGISTRATION

- For a corporation, current Certificate of Good Standing from the Missouri Secretary of State ((816) 889-2925 or (816) 889-2926 or a web site print-out, dated no more than ninety (90) days before the date furnished to the City – One Copy.
- For a business that is not a corporation and not doing business in the exact name of the proprietor, a copy from the Secretary of State, ((816) 889-2925 or (816) 889-2926 of the filed Registration of Fictitious Name dated no more than ninety (90) days before the date furnished to the City – One Copy.

EMPLOYEE ELIGIBILITY VERIFICATION AFFIDAVIT [Required if the contract exceeds \$5,000.00]

- 00515.01 Employee Eligibility Verification Affidavit – One Executed Affidavit
- First and last pages of the E-Verify Program Memorandum of Understanding that your company has received from the U.S. Department of Homeland Security verifying enrollment in the program. For assistance, contact E-Verify Operations at 888-464-4218 – One Copy.

SUBCONTRACTORS LISTING [Applicable form provided]

- Non-Construction Subcontractors List – One Copy
- 01290.09 Subcontractors & Major Material Suppliers List – One Copy

PAYMENT BONDS (If applicable)

- Each copy of the Payment bond must be signed and properly dated by the following, as applicable:

Corporation - A corporate officer authorized to sign on behalf of the corporation and the signature must be attested by a witness to the signature; OR

Limited Liability Company - A member of the limited liability company authorized to sign on behalf of the company and a witness to the signature must attest the signature; OR

Partnership - A partner authorized to sign on behalf of the partnership and the signature must be attested by a witness to the signature; OR

Sole Proprietor - By the proprietor and the signature must be attested by a witness to the signature; OR

Joint Venture - The parties to the Joint Venture authorized to sign on behalf of each party to the Joint Venture, or a person authorized by each party to the Joint Venture to sign on behalf of all parties to the Joint Venture; AND

Surety - A person authorized by the Surety to sign on behalf of the Surety. A power of attorney issued by the Surety Company authorizing its representative to sign the Agreement must be attached to the Agreement and each copy.

PERFORMANCE AND MAINTENANCE BOND (If applicable)

- As applicable, each copy of the Performance and Maintenance bond must be signed and properly dated by:

Corporation - A corporate officer authorized to sign on behalf of the corporation and the signature must be attested by a witness to the signature; OR

Limited Liability Company - A member of the limited liability company authorized to sign on behalf of the company and a witness to the signature must attest the signature; OR

Partnership - A partner authorized to sign on behalf of the partnership and the signature must be attested by a witness to the signature; OR

Sole Proprietor - By the proprietor and the signature must be attested by a witness to the signature; OR

Joint Venture - The parties to the Joint Venture authorized to sign on behalf of each party to the Joint Venture, or a person authorized by each party to the Joint Venture to sign on behalf of all parties to the Joint Venture; AND

Surety - A person authorized by the Surety to sign on behalf of the Surety. A power of attorney issued by the Surety Company authorizing its representative to sign the Agreement must be attached to the Agreement and each copy.

CERTIFICATES OF INSURANCE [Sample form provided] - If you have any questions regarding requirements for insurance certificates, please contact the City's Risk Management Office, 816 513-1299.

- Provide a certificate of insurance for all insurance that may be required in the contract such as:
 - Commercial General Liability
 - Workers' Compensation and Employers' Liability
 - Commercial Automobile Liability
 - Railroad Protective Liability
 - Environmental Liability
 - Asbestos Liability
 - Longshoremen's Insurance
 - Property Insurance
- List the NAIC Number (National Association of Insurance Commissioners) or A.M. Best Number for each Insurer listed on the Certificate of Insurance.
- Certificate "Kansas City, Missouri" must be named as an Additional Insured.
- Check the insurance requirements of the Contract. If Contract Documents require that other entities be included as additional insureds, each entity shall be listed on the certificate(s).
- Description of Operations must include Project/Contract Number and Project/Contract Title/Description as contained in the Contract Documents. The Certificate Holder and address block shall be completed as follows:

**Kansas City, Missouri
Water Services Department
Todd Rohr, Project Manager
4800 E. 63rd Street
Kansas City, Missouri 64130**
- If your insurance agent prepares an ACORD form, the automobile insurance must be "any auto" or better for acceptance by the City.

AFFIRMATIVE ACTION REQUIREMENTS

- Proposed Affirmative Action Program or a copy of a Certificate of Affirmative Action Compliance – One copy.

PRE-CONTRACT BIDDER'S CERTIFICATION (Prevailing Wage Contracts; Form provided)

- Submit form 00490 - Bidder's Pre-Contract Certification (provided).

HEALTH AND SAFETY PLAN (If applicable)

- Bidder's Health and Safety Plan – One copy or one CD Rom.

EMPLOYEE ELIGIBILITY VERIFICATION AFFIDAVIT

(Required for any contract with the City of Kansas City, Missouri in excess of \$5,000.00)

STATE OF _____)
) ss
COUNTY OF _____)

On this _____ day of _____, 20____, before me appeared _____, personally known by me or otherwise proven to be the person whose name is subscribed on this affidavit and who, being duly sworn, stated as follows:

I am of sound mind, capable of making this affidavit, and personally swear or affirm that the statements made herein are truthful to the best of my knowledge. I am the _____ (title) of _____ (business entity) and I am duly authorized, directed or empowered to act with full authority on behalf of the business entity in making this affidavit.

I hereby swear or affirm that the business entity does not knowingly employ any person in connection with the contracted services who does not have the legal right or authorization under federal law to work in the United States as defined in 8 U.S.C. § 1324a(h)(3).

I hereby additionally swear or affirm that the business entity is enrolled in an electronic verification of work program operated by the United States Department of Homeland Security (E-Verify) or an equivalent federal work authorization program operated by the United States Department of Homeland Security to verify information of newly hired employees, under the Immigration Reform and Control Act of 1986, and that the business entity will participate in said program with respect to any person hired by the business entity to perform any work in connection with the contracted services. I have attached hereto documentation sufficient to establish the business entity’s enrollment and participation in the required electronic verification of work program.

I am aware and recognize that unless certain contractual requirements are satisfied and affidavits obtained as provided in Section 285.530, RSMo, the business entity may face liability for violations committed by its subcontractors, notwithstanding the fact that the business entity may itself be compliant.

I acknowledge that I am signing this affidavit as the free act and deed of the business entity and that I am not doing so under duress.

Affiant's signature

Subscribed and sworn to before me this _____ day of _____, 20____.

Notary Public

My Commission expires:



Missouri Department of Revenue
Project Exemption Certificate

This form is to be completed and given to your contractor.

Exempt Entity and Project Information	Name of Exempt Entity Issuing the Certificate		Missouri Tax Exemption Number			
	Address		City		State	ZIP Code
	E-mail Address					
	Project Number	Project Begin Date (MM/DD/YYYY) ____/____/____		Estimated Project End Date (MM/DD/YYYY) ____/____/____		
	Description of Project					
	Project Location			Certificate Expiration Date (MM/DD/YYYY) ____/____/____		
	Provide a signed copy of this certificate, along with a copy of the exempt entity's Missouri Sales and Use Tax Exemption Letter to each contractor or subcontractor who will be purchasing tangible personal property for use in this project. It is the responsibility of the exempt entity to ensure the validity of the information on the certificate. The exempt entity must issue a new certificate if any of the information changes.					
Signature of Authorized Exempt Entity		Printed Name of Authorized Exempt Entity		Date (MM/DD/YYYY) ____/____/____		

Contractor	The Missouri exempt entity named above hereby authorizes the purchase, without sales tax, of tangible personal property to be incorporated or consumed in the construction project identified herein and no other, pursuant to Section 144.062, RSMo . Under penalties of perjury, I declare that the above information and any attached supplement is true, complete, and correct.					
	Name of Purchasing Contractor		Signature of Contractor		Date (MM/DD/YYYY) ____/____/____	
	Address		City		State	ZIP Code

Subcontractor	Contractors - Present this to your supplier in order to purchase the necessary materials tax exempt. Complete the Subcontractor portion if extending the certificate to your subcontractor. The contractor must sign the form in the space provided below.					
	Name of Purchasing Subcontractor					
	Address		City		State	ZIP Code
	Signature of Contractor		Contractor's Printed Name		Date (MM/DD/YYYY) ____/____/____	

Form 5060 (Revised 08-2015)

Taxation Division
P.O Box 358
Jefferson City, MO 65105-0358

Phone: (573) 751-2836
Fax: (573) 522-1271
E-mail: salestaxexemptions@dor.mo.gov

Visit <http://dor.mo.gov/business/sales/sales-use-exemptions.php> for additional information.



State of Missouri

EXEMPTION FROM MISSOURI SALES AND USE TAX ON PURCHASES

Issued to:

CITY OF KANSAS CITY
414 E 12TH ST 3RD FLOOR
KANSAS CITY MO 64106

Missouri Tax ID
Number: 12490466

Effective Date:
07/11/2002

Your application for sales/use tax exempt status has been approved pursuant to Section 144.030.1, RSMo. This letter is issued as documentation of your exempt status.

Purchases by your Agency are not subject to sales or use tax if within the conduct of your Agency's exempt functions and activities. When purchasing with this exemption, furnish all sellers or vendors a copy of this letter. This exemption may not be used by individuals making personal purchases.

A contractor may purchase and pay for construction materials exempt from sales tax when fulfilling a contract with your Agency only if your Agency issues a project exemption certificate and the contractor makes purchases in compliance with the provisions of Section 144.062, RSMo.

Sales by your Agency are subject to all applicable state and local sales taxes. If you engage in the business of selling tangible personal property or taxable services at retail, you must obtain a Missouri Retail Sales Tax License and collect and remit sales tax.

This is a continuing exemption subject to legislative changes and review by the Director of Revenue. If your Agency ceases to qualify as an exempt entity, this exemption will cease to be valid. This exemption is not assignable or transferable. It is an exemption from sales and use taxes only and is not an exemption from real or personal property tax.

Any alteration to this exemption letter renders it invalid.

If you have any questions regarding the use of this letter, please contact the Division of Taxation and Collection, P.O. Box 3300, Jefferson City, MO 65105-3300, phone 573-751-2836.



PERFORMANCE AND MAINTENANCE BOND

Project/Contract Numbers 60XX0028/9835

Project Title WD Asphalt and Concrete, City Wide

KNOW ALL MEN BY THESE PRESENTS: That _____, as PRINCIPAL (CONTRACTOR), and _____, (SURETY), licensed to do business as such in the State of Missouri, hereby bind themselves and their respective heirs, executors, administrators, successors, and assigns unto Kansas City, Missouri, a constitutionally chartered municipal corporation, (OWNER), as obligee, in the penal sum of _____ Dollars (\$ _____) for the payment whereof CONTRACTOR and SURETY bind themselves, their heirs, executors, administrators, successors and assigns, jointly and severally, firmly by these presents.

WHEREAS,

CONTRACTOR has entered into a Contract with OWNER for **Project/Contract Nos. 60XX0028/9835, WD Asphalt and Concrete, City Wide**, which Contract, including any present or future amendment thereto, is incorporated herein by reference and is hereinafter referred to as the Contract.

NOW, THEREFORE, THE CONDITION OF THIS OBLIGATION is such that, if CONTRACTOR shall promptly and faithfully perform said Contract including all duly authorized changes thereto, and including any maintenance requirements contained therein, according to all the terms thereof, including those under which CONTRACTOR agrees to pay legally required wage rates including the prevailing hourly rate of wages in the locality, as determined by the Department of Labor and Industrial Relations or by final judicial determination, for each craft or type of workman required to execute the Contract and, further, shall defend, indemnify, and hold harmless OWNER from all damages, including but not limited to, liquidated damages, loss and expense occasioned by any failure whatsoever of said CONTRACTOR and SURETY to fully comply with and carry out each and every requirement of the Contract, then this obligation shall be void; otherwise, it shall remain in full force and effect.

WAIVER. That SURETY, for value received, hereby expressly agrees that no change, extension of time, alteration or addition to the terms of the Contract or to the Work to be performed thereunder, shall in any way affect the obligations of this Bond; and it does hereby waive notice of any such change, extension of time, or alteration or addition to the terms of the Contract or the Work to be performed thereunder.

IN WITNESS WHEREOF, the above parties have executed this instrument the ____ day of _____, 20__.

CONTRACTOR

Name, address and facsimile number of Contractor

I hereby certify that I have authority to execute this document on behalf of Contractor.

By: _____
Title: _____

(Attach corporate seal if applicable)

SURETY

Name, address and facsimile number of Surety:

I hereby certify that (1) I have authority to execute this document on behalf of Surety; (2) Surety has an A.M. Best rating of A-, V, or better; (3) Surety is named in the current list of "Companies Holding Certificates of Authority as Acceptable Reinsuring Companies: as published in Circular 570 (most current revision) by the Financial Management Service, Surety Bond Branch, U.S. Department of the Treasury; and (4) Surety is duly licensed to issue bonds in the State of Missouri and in the jurisdiction in which the Project is located.

By: _____
Title: _____
Date: _____

(Attach seal and Power of Attorney)



PAYMENT BOND

Project/Contract Numbers 60XX0028/9835-1

Project Title WD Asphalt and Concrete, City Wide Renewal No. 1

KNOW ALL MEN BY THESE PRESENTS: That Superior and Bowen Asphalt Company, as PRINCIPAL (CONTRACTOR), and _____, (SURETY), licensed to do business as such in the State of Missouri, hereby bind themselves and their respective heirs, executors, administrators, successors, and assigns unto Kansas City, Missouri, a constitutionally chartered municipal corporation, (OWNER), as obligee, in the penal sum of _____ Dollars (\$_____) for the payment whereof CONTRACTOR and SURETY bind themselves, their heirs, executors, administrators, successors and assigns, jointly and severally, firmly by these presents.

WHEREAS,

CONTRACTOR has entered into a contract with OWNER for **Project/Contract Nos. 60XX0028/9835-1, WSD Asphalt and Concrete, City Wide Renewal No. 1**, which Contract, including any present or future amendment thereto, is incorporated herein by reference and is hereinafter referred to as the Contract.

NOW, THEREFORE, THE CONDITION OF THIS OBLIGATION is such that, if in connection with the Contract, including all duly authorized modifications thereto, prompt payment shall be made to all laborers, subcontractors, teamsters, truck drivers, owners or other suppliers or for equipment employed on the job, and other claimants, for all labor performed in such work whether done for CONTRACTOR, a subcontractor, SURETY, a completion contractor or otherwise (at the full wage rates required by any law of the United States or of the State of Missouri, where applicable), for services furnished and consumed, for repairs on machinery, for equipment, tools, materials, lubricants, oil, gasoline, water, gas, power, light, heat, oil, telephone service, grain, hay, feed, coal, coke, groceries and foodstuffs, either consumed, rented, used or reasonably required for use in connection with the construction of the work or in the performance of the Contract and all insurance premiums, both for compensation and for all other kinds of insurance on the work, for sales taxes and for royalties in connection with, or incidental to, the completion of the Contract, in all instances whether the claim be directly against CONTRACTOR, against SURETY or its completion contractor, through a subcontractor or otherwise, and, further, if CONTRACTOR shall defend, indemnify and hold harmless OWNER from all such claims, demands or suits by any such person or entity, then this obligation shall be void; otherwise, it shall remain in full force and effect.

Any conditions legally required to be included in a Payment Bond on this Contract, including but not limited to those set out in §107.170 RSMo. are included herein by reference.

SURETY agrees that, in the event that CONTRACTOR fails to make payment of the obligations covered by this Bond, it will do so and, further, that within forty-five (45) days of receiving, at the address given below, a claim hereunder stating the amount claimed and the basis for the claim in reasonable detail, it (a) will send an answer to the claimant, with a copy to OWNER stating the amounts that are undisputed and the basis for challenging any amounts that are disputed, and (b) will pay any amounts that are undisputed. The amount of this Bond shall be reduced by and to the extent of any payment or payments made in good faith hereunder.

While this Bond is in force, it may be sued on at the instance of any party to whom any such payment is due, in the name of OWNER to the use for such party. OWNER shall not be liable for the payment of any costs or expenses of any such suit.

No suit shall be commenced or pursued hereunder other than in a state court of competent jurisdiction in Jackson, Clay or Platte County, Missouri, or in the United States District Court for the Western District of Missouri.

WAIVER. That SURETY, for value received, hereby expressly agrees that no change, extension of time, alteration or addition to the terms of the Contract or to the Work to be performed thereunder, shall in any way affect the obligations of this Bond; and it does hereby waive notice of any such change, extension of time, or alteration or addition to the terms of the Contract or the Work to be performed thereunder.

IN WITNESS WHEREOF, the above parties have executed this instrument the _____ day of _____, 20_____.

CONTRACTOR

Name, address and facsimile number of Contractor

I hereby certify that I have authority to execute this document on behalf of Contractor.

By: _____
Title: _____

(Attach corporate seal if applicable)

SURETY

Name, address and facsimile number of Surety:

I hereby certify that (1) I have authority to execute this document on behalf of Surety; (2) Surety has an A.M. Best rating of A- or better; (3) Surety is named in the current list of "Companies Holding Certificates of Authority as Acceptable Sureties on Federal Bonds and as Acceptable Reinsuring Companies" as published in Circular 570 (most current revision) by the Financial Management Service, Surety Bond Branch, U.S. Department of the Treasury; and(4) Surety is duly licensed to issue bonds in the State of Missouri and in the jurisdiction in which the Project is located.

By: _____
Title: _____
Date: _____

(Attach seal and Power of Attorney)



CERTIFICATE OF LIABILITY INSURANCE

DATE (MM/DD/YYYY)

THIS CERTIFICATE IS ISSUED AS A MATTER OF INFORMATION ONLY AND CONFERS NO RIGHTS UPON THE CERTIFICATE HOLDER. THIS CERTIFICATE DOES NOT AFFIRMATIVELY OR NEGATIVELY AMEND, EXTEND OR ALTER THE COVERAGE AFFORDED BY THE POLICIES BELOW. THIS CERTIFICATE OF INSURANCE DOES NOT CONSTITUTE A CONTRACT BETWEEN THE ISSUING INSURER(S), AUTHORIZED REPRESENTATIVE OR PRODUCER, AND THE CERTIFICATE HOLDER.

IMPORTANT: If the certificate holder is an ADDITIONAL INSURED, the policy(ies) must be endorsed. If SUBROGATION IS WAIVED, subject to the terms and conditions of the policy, certain policies may require an endorsement. A statement on this certificate does not confer rights to the certificate holder in lieu of such endorsement(s).

PRODUCER AGENT NAME AND ADDRESS	CONTACT NAME:	
	PHONE (A/C, No, Ext):	FAX (A/C, No):
INSURED CONTRACTOR NAME AND ADDRESS	E-MAIL ADDRESS:	
	INSURER(S) AFFORDING COVERAGE	
	INSURER A : ABC INSURANCE COMPANY	
	INSURER B :	
	INSURER C :	
	INSURER D :	
INSURER E :		
INSURER F :		

COVERAGES **CERTIFICATE NUMBER:** **REVISION NUMBER:**

THIS IS TO CERTIFY THAT THE POLICIES OF INSURANCE LISTED BELOW HAVE BEEN ISSUED TO THE INSURED NAMED ABOVE FOR THE POLICY PERIOD INDICATED. NOTWITHSTANDING ANY REQUIREMENT, TERM OR CONDITION OF ANY CONTRACT OR OTHER DOCUMENT WITH RESPECT TO WHICH THIS CERTIFICATE MAY BE ISSUED OR MAY PERTAIN, THE INSURANCE AFFORDED BY THE POLICIES DESCRIBED HEREIN IS SUBJECT TO ALL THE TERMS, EXCLUSIONS AND CONDITIONS OF SUCH POLICIES. LIMITS SHOWN MAY HAVE BEEN REDUCED BY PAID CLAIMS.

INSR LTR	TYPE OF INSURANCE	ADDL INSR	SUBR WVD	POLICY NUMBER	POLICY EFF (MM/DD/YYYY)	POLICY EXP (MM/DD/YYYY)	LIMITS
A	GENERAL LIABILITY <input checked="" type="checkbox"/> COMMERCIAL GENERAL LIABILITY <input type="checkbox"/> CLAIMS-MADE <input checked="" type="checkbox"/> OCCUR GEN'L AGGREGATE LIMIT APPLIES PER: <input type="checkbox"/> POLICY <input checked="" type="checkbox"/> PROJECT <input type="checkbox"/> LOC	Y	Y	POLICY NUMBER	1/1/2011	Current	EACH OCCURRENCE \$ 1,000,000 DAMAGE TO RENTED PREMISES (Ea occurrence) \$ 50,000 MED EXP (Any one person) \$ 10,000 PERSONAL & ADV INJURY \$ 1,000,000 GENERAL AGGREGATE \$ 2,000,000 PRODUCTS - COMP/OP AGG \$ 2,000,000 \$
A	AUTOMOBILE LIABILITY <input checked="" type="checkbox"/> ANY AUTO ALL OWNED AUTOS <input checked="" type="checkbox"/> HIRED AUTOS <input type="checkbox"/> SCHEDULED AUTOS NON-OWNED AUTOS	Y	Y	POLICY NUMBER	1/1/2011	Current	COMBINED SINGLE LIMIT (Ea accident) \$ 1,000,000 BODILY INJURY (Per person) \$ BODILY INJURY (Per accident) \$ PROPERTY DAMAGE (Per accident) \$ \$
A	<input checked="" type="checkbox"/> UMBRELLA LIAB <input checked="" type="checkbox"/> EXCESS LIAB <input checked="" type="checkbox"/> RETENTION \$ 10,000 <input type="checkbox"/> OCCUR CLAIMS-MADE	Y	Y	POLICY NUMBER	1/1/2011	Current	EACH OCCURRENCE \$ 2,000,000 AGGREGATE \$ 2,000,000 \$
A	WORKERS COMPENSATION AND EMPLOYERS' LIABILITY ANY PROPRIETOR/PARTNER/EXECUTIVE OFFICER/MEMBER EXCLUDED? (Mandatory in NH) If yes, describe under DESCRIPTION OF OPERATIONS below Y/N <input checked="" type="checkbox"/> N	N/A	Y	POLICY NUMBER	1/1/2011	Current	<input checked="" type="checkbox"/> WC STATUTORY LIMITS <input type="checkbox"/> OTHER E.L. EACH ACCIDENT \$ 1,000,000 E.L. DISEASE - EA EMPLOYEE \$ 1,000,000 E.L. DISEASE - POLICY LIMIT \$ 1,000,000
A	Leased/Rented/Equip. Owned Equipment Builders Risk/Installation Floater	N/A	Y	POLICY NUMBER	1/1/2011	Current	Limit; Deductible Limit; Deductible Limit; Deductible

DESCRIPTION OF OPERATIONS / LOCATIONS / VEHICLES (Attach ACORD 101, Additional Remarks Schedule, if more space is required)

Project No. _____ [Title]. Certholder (City) and _____ (Design Professional) and any other entities named in 00800 SCs are named as primary, noncontributing Additional Insureds including products and completed operations, excluding workers compensation, employers liability and professional liability. Waiver of subrogation applies as allowed by law. [The policies required above shall contain no exclusions for work expressly within the subcontractors scope of work.]

CERTIFICATE HOLDER City of Kansas City, Missouri _____ [Department] _____ [Address] Kansas City, MO _____ [Zip]	CANCELLATION SHOULD ANY OF THE ABOVE DESCRIBED POLICIES BE CANCELLED BEFORE THE EXPIRATION DATE THEREOF, NOTICE WILL BE DELIVERED IN ACCORDANCE WITH THE POLICY PROVISIONS.
	AUTHORIZED REPRESENTATIVE



AUTHORIZATION TO RELEASE A REVENUE CLEARANCE LETTER

Revenue Division
414 East 12th Street, 2nd floor, Room 202 W
Kansas City, MO 64106 Phone (816) 513-1135 Fax (816) 513-1077 email: revenue@kcmo.org

I authorize the City of Kansas City, Missouri, Finance Department, Revenue Division, to release a Revenue Clearance Letter for:

Name of Taxpayer: _____ Tax I.D.# _____
(PRINT)

Address: _____

Check this box and the City will send the Clearance Letter to you or the contractor designated.

I authorize the City to provide a copy of the Taxpayer's Revenue Clearance Letter to the following:

NAME <i>(PRINT)</i>	BUSINESS NAME	TITLE
ADDRESS	CITY, STATE, ZIP CODE	
PHONE NUMBER	FAX NUMBER	E-MAIL ADDRESS

I authorize the City to provide the Taxpayer's Revenue Clearance Letter to all City Departments and to publish on the City's internet/intranet website that the Taxpayer is in compliance with the tax ordinances administered by the City's Commissioner of Revenue.

Please send my 1st Revenue Clearance Letter to: _____
(Print Name of City Department/Contact Person/E-mail/Fax Number)

This authorization shall expire one (1) year from the date of the signature.

The City, Commissioner of Revenue and the Revenue Division personnel (hereinafter "the City"), are hereby held harmless from any and all liability relating to unauthorized disclosure of confidential tax information resulting from release of information under all applicable confidentiality laws including federal, state, or local including any damages sustained by wrongful transmission of confidential tax information to any other person.

UNDER PENALTIES OF PERJURY, I DECLARE THAT I HAVE EXAMINED THIS AUTHORIZATION, AND TO THE BEST OF MY KNOWLEDGE AND BELIEF, IT IS TRUE, CORRECT AND COMPLETE.

I hereby certify that I am the Taxpayer named herein or that I have the authority to execute this authorization and hold harmless agreement on behalf of the Taxpayer.

NAME <i>(PRINT)</i>	TITLE <i>(IF APPLICABLE)</i>	
SIGNATURE	PHONE NUMBER	DATE

A FACSIMILE OF THIS DOCUMENT SHALL CONSTITUTE AN ORIGINAL



KANSAS CITY
MISSOURI

Finance Department

Revenue Division

414 E 12th St. 1st Floor
Kansas City, MO 64106-2786

**DO NOT MAIL
atL003**

Phone: (816) 513-1120

Fax: (816) 513-1264

Email: revenue@kcmo.org

Website: kcmo.gov/tax

Letter Id: L0000143555

Date: 07-Feb-2024

Taxpayer Id: 0000161779

EXAMPLE TAXPAYER
414 E 12TH ST
KANSAS CITY MO 64106-2702



TAX CLEARANCE STATUS: APPROVED

As of this date, this notice is to inform you that EXAMPLE TAXPAYER is current with all taxes and license fees with the City of Kansas City, Mo., Finance Department/ Revenue Division.

Please note this could change if we perform a full review of your accounts in the future. We will let you know if we need to review your accounts. You will need to pay any amounts that are found due at that time.

Eric Davison
Commissioner of Revenue

Visit kcmo.gov/quicktax to view the status of your account and for online filing.





GENERAL CONDITIONS TABLE OF CONTENTS

ARTICLE 1 DEFINITIONS AND TERMINOLOGY

- 1.01 Defined Terms
- 1.02 Terminology

ARTICLE 2 PRELIMINARY MATTERS

- 2.01 Delivery of Bonds
- 2.02 Evidence of Insurance
- 2.03 Copies of Documents
- 2.04 Commencement of Contract Times; Notice to Proceed
- 2.05 Starting the Work
- 2.06 Before Starting Construction
- 2.07 Initially Acceptable Schedules

ARTICLE 3 CONTRACT DOCUMENTS: INTENT, AMENDING, REUSE

- 3.01 Intent
- 3.02 Reference to Standards and Specifications of Technical Societies
- 3.03 Reporting and Resolving Discrepancies
- 3.04 Amending and Supplementing Contract Documents
- 3.05 Reuse of Documents

ARTICLE 4 AVAILABILITY OF LANDS; SUBSURFACE AND PHYSICAL CONDITIONS; REFERENCE POINTS

- 4.01 Availability of Lands
- 4.02 Subsurface and Physical Conditions
- 4.03 Differing Subsurface or Physical Conditions
- 4.04. Physical Conditions - Underground Facilities
- 4.05 Reference Points
- 4.06 Asbestos, Lead-Based Paint, PCBs, Petroleum, Hazardous Waste or Radioactive Material

ARTICLE 5 BONDS AND INSURANCE

- 5.01 Performance, Payment and Other Bonds
- 5.02 Licensed Sureties and Insurers
- 5.03 Certificates of Insurance
- 5.04 CONTRACTOR's Liability Insurance
- 5.05 CITY's Liability Insurance
- 5.06 Property Insurance
- 5.07 Waiver of Rights
- 5.08 Receipt and Application of Insurance Proceeds
- 5.09 Partial Utilization - Property Insurance

ARTICLE 6 CONTRACTOR'S RESPONSIBILITIES

- 6.01 Indemnification

- 6.02 Supervision and Superintendence
- 6.03 Services, Working Hours, Labor, Materials and Equipment
- 6.04 Progress Schedule
- 6.05 Recovery Schedules
- 6.06 Substitutes and "Or-Equal" Items
- 6.07 Concerning Subcontractors, Suppliers and Others
- 6.08 Patent Fees and Royalties
- 6.09 Permits
- 6.10 Laws or Regulations
- 6.11 Taxes
- 6.12 Use of Site and Other Areas
- 6.13 Record Documents
- 6.14 Safety and Protection
- 6.15 Safety Representative
- 6.16 Hazard Communication Programs
- 6.17 Emergencies
- 6.18 Shop Drawings and Samples
- 6.19 Continuing the Work
- 6.20 CONTRACTOR's General Warranty and Guarantee

ARTICLE 7 OTHER WORK

- 7.01 Related Work at Site
- 7.02 Coordination

ARTICLE 8 CITY's RESPONSIBILITIES

- 8.01 Communications to CONTRACTOR
- 8.02 Replacement of DESIGN PROFESSIONAL
- 8.03 Furnish Data and Prompt Payment
- 8.04 Lands and Easements; Reports and Tests
- 8.05 Insurance
- 8.06 Change Orders
- 8.07 Inspections, Tests and Approvals
- 8.08 Limitations on CITY's Responsibilities
- 8.09 Undisclosed Hazardous Environmental Condition
- 8.10 Evidence of Financial Arrangements
- 8.11 CITY's Representative
- 8.12 Visits to Site

ARTICLE 9 DESIGN PROFESSIONAL's STATUS DURING CONSTRUCTION

- 9.01 General Scope of DESIGN PROFESSIONAL's Duties
- 9.02 Resident Project Representative
- 9.03 Clarifications and Interpretations
- 9.04 Rejecting Defective Work
- 9.05 Shop Drawings, Change Orders and Payments
- 9.06 Determinations for Unit Prices
- 9.07 Decisions on Requirements of Contract Documents and Acceptability of Work
- 9.08 Limitations on DESIGN PROFESSIONAL's Authority and Responsibilities

ARTICLE 10 CHANGES IN THE WORK

- 10.01 Authorized Changes in the Work
- 10.02 Unauthorized Changes in the Work
- 10.03 Execution of Change Orders
- 10.04 Notification to Surety

ARTICLE 11 CHANGE OF CONTRACT PRICE

- 11.01 Change of Contract Price
- 11.02 Cost of the Work
- 11.03 Cash Allowances
- 11.04 Unit Price Work
- 11.05 Dispute Resolution

ARTICLE 12 CONTRACT TIMES

- 12.01 Time of the Essence
- 12.02 Change of Contract Times
- 12.03 Proof Required To Justify An Extension of Time For Excusable and Compensable Delays
- 12.04 Delays Within CONTRACTOR's Control
- 12.05 Delays Beyond the CITY's and CONTRACTOR's Control
- 12.06 Delay Damages
- 12.07 Dispute Resolution

ARTICLE 13 TESTS AND INSPECTIONS; CORRECTION, REMOVAL OR ACCEPTANCE OF DEFECTIVE WORK

- 13.01 Access to Work
- 13.02 Tests and Inspections
- 13.03 Notice of Defects
- 13.04 Uncovering Work
- 13.05 CITY May Stop the Work
- 13.06 Correction or Removal of Defective Work
- 13.07 Correction Period
- 13.08 Acceptance of Defective Work
- 13.09 CITY May Correct Defective Work

ARTICLE 14 PAYMENTS TO CONTRACTOR AND COMPLETION

- 14.01 Schedule of Values
- 14.02 Application for Progress Payments
- 14.03 Contractor's Warranty of Title
- 14.04 Substantial Completion
- 14.05 Partial Utilization
- 14.06 Final Inspection
- 14.07 Final Payment
- 14.08 Final Completion Delayed
- 14.09 Waiver of Claims
- 14.10 Completion of Work by City

ARTICLE 15 SUSPENSION OF WORK AND TERMINATION

- 15.01 CITY May Suspend Work
- 15.02 CITY May Terminate for Default
- 15.03 CITY May Terminate for Convenience

ARTICLE 16 CLAIMS AND DISPUTES

- 16.01 Definition
- 16.02 Written Notice and Burden of Proof
- 16.03 Time Limits on Claims
- 16.04 Continuing Contract Performance
- 16.05 Injury or Damage to Person or Property
- 16.06 Initial Resolution of Claims and Disputes

16.07 Final Resolution of Claims and Disputes

ARTICLE 17 MISCELLANEOUS

17.01 Giving Notice

17.02 Computation of Times

17.03 Cumulative Remedies

17.04 Survival of Obligations

17.05 Controlling Law

ARTICLE 1 DEFINITIONS AND TERMINOLOGY

1.01 Defined Terms

A. Wherever used in these General Conditions or in the other Contract Documents, the following terms have the meanings indicated which are applicable to both the singular and plural thereof:

1. Addenda - Written or graphic instruments issued prior to the opening of Bids that clarify, correct or change the Bidding Requirements or the Contract Documents.

2. Agreement—The written Contract between CITY and CONTRACTOR governing the Work to be performed; other Contract Documents are attached to the Agreement and made a part thereof as provided therein.

3. Application for Payment—The form accepted by CITY's Representative which is to be used by CONTRACTOR in requesting progress or final payments and which is to be accompanied by such supporting documentation as is required by the Contract Documents.

4. Asbestos - Any material that contains more than one percent (1%) Asbestos and is friable or is releasing Asbestos fibers into the air above current action levels established by the United States Occupational Safety and Health Administration.

5. Bid- The offer or proposal of the Bidder submitted on the Bid Form/Contract setting forth the prices for the Work to be performed. A Bidder's Bid becomes a Contract with CITY if the CITY executes the Bid Form/Contract submitted by Bidder. If the CITY executes the Bid Form/Contract submitted by Bidder, the term "Bidder" shall mean CONTRACTOR.

6. Bidder- One who submits a Bid directly to CITY, as distinct from a sub-bidder who submits a bid to a Bidder. If the CITY executes the Bid Form/Contract submitted by Bidder, the term "Bidder" shall mean CONTRACTOR in both the Bidding Documents and Contract Documents unless the context clearly indicates otherwise.

7. Bidding Documents- The advertisement or Invitation to Bid, Instructions to Bidders, the Bid Form/Contract, and the proposed Contract Documents (including all Addenda issued prior to receipt of Bids).

8. Bidding Requirements- The advertisement or invitation to bid, Instructions to Bidders, Bid security, and the Bid Form/Contract with any supplements.

9. Bonds- Payment Bond and Performance and Maintenance Bond and other instruments of security.

10. Calendar Day- Any day shown on the calendar, including Saturdays, Sundays, and holidays.

11. Change Order- A written document issued by CITY that authorizes an addition, deletion or revision in the Work, or an adjustment in the Contract Price or the Contract Times, issued on or after the Effective Date of the Contract.

12. CITY/OWNER- Kansas City, Missouri, a constitutionally chartered municipal corporation, with which CONTRACTOR has entered into the Contract and for whom the Work is to be provided.

13. CITY's Representative- Person or agency designated to act for the Director as provided in these Contract Documents.

14. Consultant- Person, firm or corporation having a contract with CITY or DESIGN PROFESSIONAL to furnish services as an independent professional associate or Consultant with respect to the Project and who's identified as such in the Supplementary Conditions.

The Consultant(s) is identified and their seals affixed on the Certification Page(s). The certifications describe the respective responsibilities for the Drawings and Specifications prepared by the Consultant(s) and are incorporated into this Contract.

15. Contract- The entire and integrated written agreement between CITY and CONTRACTOR concerning the Work that incorporates all Contract Documents. The Bid Form/Contract submitted by Bidder is the Contract between CITY and CONTRACTOR upon execution by CITY. The Contract supersedes prior negotiations, representations, or agreements, whether written or oral.

16. Contract Documents- The Contract Documents establish the rights and obligations of the parties and include the Contract, Addenda (which pertain to the Contract Documents), CONTRACTOR's Bid Form/Contract (including documentation accompanying the Bid and any post Bid documentation submitted prior to the Notice of Intent to Contract), the Construction Project Instructions, the Contractor's Utilization Plan/Request for Waiver, the Notice to Proceed, the Bonds, these General Conditions, the Supplementary Conditions, the Specifications and the Drawings as the same are more specifically identified in the Project Manual and the certification page(s) of the DESIGN PROFESSIONAL and Consultant(s), together with approved project baseline schedule and amendments thereto and all Written Amendments, Change Orders, Work Change Directives, and DESIGN PROFESSIONAL's written interpretations and clarifications issued on or after the Effective Date of the Contract, and approved Shop Drawings. Reports and drawings of subsurface and physical conditions are not Contract Documents. Only printed or hard copies of the items listed in this Paragraph are Contract Documents. Files in electronic media format of text, data, graphics, and the like that may be furnished by CITY to CONTRACTOR are not Contract Documents, except project schedules submitted by CONTRACTOR and approved by CITY.

17. Contract Price- The money payable by CITY to CONTRACTOR for completion of the Work in accordance with the Contract Documents as stated in the Agreement.

18. Contract Times- The number of days or the dates stated in the Supplementary Conditions: (a) to achieve Substantial Completion, and (b) to complete the Work so that it is ready for final payment as evidenced by CITY's Representative's written recommendation of final payment.

19. CONTRACTOR- The person, firm, partnership, company, corporation or association licensed or otherwise authorized by law to do business in Missouri, with whom CITY has entered into the Agreement.

20. Day- Shall constitute a Calendar Day.

21. DESIGN PROFESSIONAL- Architect, Engineer or other licensed professional who is either employed by or has contracted with CITY to serve in a design capacity and whose Consultants, members, partners, employees or agents have prepared and sealed the Drawings and Specifications.

The DESIGN PROFESSIONAL(s) is identified and their seals affixed on the Certification Page(s). The certifications describe the respective responsibilities for the Drawings and Specifications prepared by the DESIGN PROFESSIONAL and are incorporated into this Contract.

22. DESIGN PROFESSIONAL's Project Representative- The authorized representative of DESIGN PROFESSIONAL who may be assigned to the Site or any part thereof.

23. Director- The term Director shall mean the duly appointed executive officer of a department of City who is empowered by the City Charter or by the City Council to enter into a contract on behalf of City, or to grant a permit for improvements to land owned by City. A Director is authorized to delegate this authority to a City employee so designated in writing.

24. Drawings- The drawings which graphically show the scope, extent and character of the Work to be furnished and performed by CONTRACTOR and which have been prepared by DESIGN PROFESSIONAL and are included in the Contract Documents. Shop Drawings are not Drawings as so defined.

25. Effective Date of the Contract- The date indicated in the Contract on which it becomes effective, but if no such date is indicated it means the date on which the Contract is fully executed by CITY.

26. General Requirements- Sections of Division 1 of the Specifications. The General Requirements pertain to all sections of the Specifications.

27. Hazardous Environmental Condition- The presence at the Site of Asbestos, Lead-Based Paint, PCBs, Petroleum, Hazardous Waste, or Radioactive Material in such quantities or circumstances that may present a substantial danger to persons or property exposed thereto in connection with the Work.

28. Hazardous Waste- The term Hazardous Waste shall have the meaning provided in Section 1004 of the Solid Waste Disposal Act (42 USC Section 6903) as amended from time to time.

29. Laws or Regulations- Any and all applicable laws, rules, regulations, ordinances, codes and orders of any and all governmental bodies, agencies, authorities and courts having jurisdiction.

30. Lead-Based Paint- Any paint, varnish, stain, or other applied coating that has one (1) mg or more of lead per square centimeter. The terms "leaded paint" and "lead-containing paint" are synonymous with Lead-Based Paint.

31. Liens- Liens, charges, security interests or encumbrances upon real property or personal property.

32. Milestone- A principal event specified in the Contract Documents relating to an intermediate completion date or time prior to Substantial Completion of all the Work.

33. Notice of Intent to Contract- The written notice by CITY to the apparent successful Bidder stating that upon compliance by that apparent successful Bidder with the conditions in the Bid Documents enumerated, within the time specified, and upon enactment of an appropriate ordinance or resolution, CITY will sign and deliver the Contract.

34. Notice to Proceed- A written notice given by CITY to CONTRACTOR fixing the date on which the Contract Times will commence to run and on which CONTRACTOR shall start to perform CONTRACTOR's obligations under the Contract Documents.

35. Partial Utilization- Use by CITY of a substantially completed part of the Work for the purpose for which it is intended (or a related purpose) prior to Substantial Completion of all the Work.

36. PCBs- Polychlorinated biphenyls.

37. Petroleum- Petroleum, including crude oil or any fraction thereof which is liquid at standard conditions of temperature and pressure (60 degrees Fahrenheit and 14.7 pounds per square inch absolute), such as oil, petroleum, fuel oil, oil sludge, oil refuse, gasoline, kerosene, and oil mixed with other non-Hazardous Wastes and crude oils.

38. Project- The total construction of which the Work to be provided under the Contract Documents may be the whole, or a part as indicated elsewhere in the Contract Documents.

39. Project Manual- The documentary information prepared for bidding and constructing the Work. A listing of the contents of the Project Manual may be issued in one or more volumes and is contained in the table(s) of contents.

40. Radioactive Material- Source, special nuclear, or byproduct material as defined by the Atomic Energy Act of 1954 (42 USC Section 2011 et seq.) as amended from time to time.

41. Samples- Physical examples of materials, equipment, or workmanship that are representative of some portion of the Work and which establish the standards by which such portion of the Work will be judged.

42. Shop Drawings- All drawings, diagrams, illustrations, schedules and other data or information which are specifically prepared or assembled by or for CONTRACTOR and submitted by CONTRACTOR to illustrate some portion of the Work.

43. Site- Lands or areas indicated in the Contract Documents as being furnished by CITY upon which the Work is to be performed, including rights-of-way and easements for access thereto, and such other lands furnished by CITY which are designated for the use of CONTRACTOR.

44. Specifications- Those portions of the Contract Documents consisting of written technical descriptions of materials, equipment, construction systems, standards and workmanship as applied to the Work and certain administrative details applicable thereto.

45. Subcontractor- Any individual, firm, partnership, company, corporation or association licensed or otherwise authorized by law to do business in Missouri, to whom CONTRACTOR, with written notification to CITY, has entered into an agreement to perform a part of the Work.

46. Substantial Completion- When Work (or a specified part thereof) has progressed to the point where, in the opinion of DESIGN PROFESSIONAL as evidenced by DESIGN PROFESSIONAL's definitive certificate of Substantial Completion, it is sufficiently complete, in accordance with the Contract Documents, so that the Work (or specified part) can be utilized for the purposes for which it is intended. The terms "substantially complete" and "substantially completed" as applied to all or part of the Work refer to Substantial Completion thereof.

47. Supplementary Conditions- The part of the Contract Documents which amends and/or supplements these General Conditions.

48. Supplier- A manufacturer, fabricator, supplier, distributor, materialman or vendor having a direct contract with CONTRACTOR or with any Subcontractor to furnish materials or equipment to be incorporated into the Work by CONTRACTOR or any Subcontractor.

49. Underground Facilities- All pipelines, conduits, ducts, cables, wires, manholes, vaults, tanks, tunnels or other such facilities or attachments, and any encasements containing such facilities which have been installed underground to furnish any of the following services or materials: electricity, gases, steam, liquid petroleum products, telephone or other communications, cable television, water, wastewater, storm water, other liquids or chemicals, or traffic or other control systems.

50. Unit Price Work- Work to be paid for on the basis of unit prices.

51. Work- The entire completed construction or the various separately identifiable parts thereof required to be furnished under the Contract Documents. Work includes and is the result of performing or furnishing labor, and furnishing and incorporating material and equipment into the construction, and furnishing documents, all as required by the Contract Documents.

52. Work Change Directive- A written directive to CONTRACTOR, issued on or after the Effective Date of the Contract, signed by CITY and recommended by DESIGN PROFESSIONAL, ordering an addition, deletion or revision in the Work, or responding to differing or unforeseen subsurface or physical conditions under which the Work is to be performed, or to emergencies. A Work Change Directive will not change the Contract Price or the Contract Times, but is evidence that the parties expect that the change directed or

documented by a Work Change Directive will be incorporated in a subsequently issued Change Order following negotiations by the parties as to its effect, if any, on the Contract Price or Contract Times.

53. Work Day - Any day during which the CONTRACTOR is able to work a period of six (6) hours or more. Days that are not Work Days are days during which the CONTRACTOR is unable to work for a period of six (6) hours by reason of strikes, boycotts, labor disputes, embargoes, unusual delays in transportation or shortage of material, acts of God, acts of the public enemy, acts of superior governmental authority, weather conditions, riots, rebellion, sabotage, or any other circumstances for which CONTRACTOR is not responsible or which is not within its control. Saturdays, Sundays, and holidays on which the CONTRACTOR's forces engage in Work requiring the presence of an inspector, will be considered as Work Days.

54. Written Amendment- A written statement modifying the Contract Documents, signed by CITY and CONTRACTOR on or after the Effective Date of the Contract and normally dealing with the non-engineering or non-technical rather than strictly construction-related aspects of the Contract Documents.

1.02 Terminology

A. Intent of Certain Terms or Adjectives

1. Whenever in the Contract Documents the terms "as ordered," "as directed," "as required," "as allowed," "as approved," or terms of like effect or import are used, or the adjectives "reasonable," "suitable," "acceptable," "proper" or "satisfactory" or adjectives of like effect or import are used to describe a requirement, direction, review or judgment of DESIGN PROFESSIONAL as to the Work, it is intended that such requirement, direction, review or judgment will be solely to evaluate, in general, the completed Work for compliance with the requirements of and information in the Contract Documents and conformance with the design concept of the completed Project as a functioning whole as shown or indicated in the Contract Documents (unless there is a specific statement indicating otherwise). The use of any such term or adjective shall not be effective to assign to DESIGN PROFESSIONAL any duty or authority to supervise or direct the furnishing or performance of the Work or any duty or authority to undertake responsibility contrary to the provisions of Paragraph 9.08 or any other provision of the Contract Documents.

B. Defective

1. The word "defective," when modifying the word "Work," refers to Work that is unsatisfactory, faulty or deficient, in that it does not conform to the Contract Documents, or does not meet the requirements of any inspection, reference standard, test or approval referred to in the Contract Documents, or has been damaged prior to CITY 's Representative's recommendation of final payment (unless responsibility for the protection thereof has been assumed by CITY at Substantial Completion in accordance with Paragraph 14.04 or 14.05).

C. Furnish, Install, Perform, Provide

1. The word "furnish," when used in connection with services, materials, or equipment, shall mean to supply and deliver said services, materials, or equipment to the Site (or some other specified location) ready for use or installation and in usable or operable condition.

2. The word "install," when used in connection with services, materials, or equipment, shall mean to put into use or place in final position said services, materials, or equipment complete and ready for intended use.

3. The words "perform" or "provide," when used in connection with services, materials, or equipment, shall mean to furnish and install said services, materials, or equipment complete and ready for intended use.

4. When “furnish,” “install,” “perform,” or “provide” is not used in connection with services, materials, or equipment in a context clearly requiring an obligation of CONTRACTOR, “provide” is implied.

D. Unless stated otherwise in the Contract Documents, words and phrases which have a well-known technical or construction industry or trade meanings are used in the Contract Documents in accordance with such recognized meaning.

ARTICLE 2 PRELIMINARY MATTERS

2.01 Delivery of Bonds

A. CONTRACTOR shall deliver to CITY such Bonds as CONTRACTOR may be required to furnish.

2.02 Evidence of Insurance

A. CONTRACTOR shall deliver to CITY certificates of insurance or other evidence of insurance that CITY may request, which CONTRACTOR is required to purchase and maintain in accordance with Article 5 or any other applicable provision in the Contract Documents.

2.03 Copies of Documents

A. CITY shall furnish to CONTRACTOR one (1) copy of the Drawings and Specifications, including addenda.

2.04 Commencement of Contract Times; Notice to Proceed

A. The Contract Times will commence to run on the date indicated in the Notice to Proceed.

2.05 Starting the Work

A. CONTRACTOR shall start to perform the Work on the date when the Contract Times commence to run, but no Work shall be done at the Site prior to the date on which the Contract Times commence to run, unless otherwise indicated in the Notice to Proceed.

2.06 Before Starting Construction

A. CONTRACTOR's Review of Contract Documents: Before undertaking each part of the Work, CONTRACTOR shall carefully study and compare the Contract Documents and check and verify pertinent figures shown thereon and all applicable field measurements. CONTRACTOR shall promptly report in writing to DESIGN PROFESSIONAL any conflict, error, ambiguity or discrepancy which CONTRACTOR may discover and shall obtain a written interpretation or clarification from DESIGN PROFESSIONAL before proceeding with any Work affected thereby. CONTRACTOR shall not be liable to CITY or DESIGN PROFESSIONAL for failure to report any conflict, error, ambiguity or discrepancy in the Contract Documents, unless CONTRACTOR knew or reasonably should have known thereof.

B. Preliminary Schedules: Within ten (10) days after the Effective Date of the Contract, or on such later date as CITY's Representative shall provide in writing, CONTRACTOR shall submit to CITY's Representative for review:

1. Preliminary Project Schedule: CONTRACTOR shall submit a proposed project schedule for CITY's acceptance. The proposed project schedule shall include a detailed and comprehensive construction schedule utilizing a critical path method diagram network that (a) shows all major procurement and construction elements and phases of the Project; (b) breaks down each element or phase by trade; (c) shows early and late starts so that all float time will be accurately identified; (d) all other activities necessary for the timely completion of the Project in accordance with the scheduled dates for Substantial and Final Completion; and (e) highlights the project's critical path. CITY's acceptance is expressly limited to CITY's acknowledgement that, based upon CITY's limited review, the dates of Substantial

Completion and Milestone dates are acceptable. After final acceptance of the preliminary project schedule by the CITY, it shall be considered the project baseline schedule pursuant to Paragraph 2.07(B).

2. Preliminary schedule of Shop Drawings and Sample submittals which will list each required submittal and the times for submitting, reviewing and processing such submittal; and

3. Preliminary 01290.02 Schedule of Values for all of the Work which will include quantities and prices of items which when added together equals the Contract Price and will subdivide the Work into component parts in sufficient detail to serve as the basis for progress payments during performance of the Work. Such prices will include an appropriate amount of overhead and profit applicable to each item of Work.

C. Preconstruction Conference: Before any Work at the Site may be started, a conference attended by CONTRACTOR, DESIGN PROFESSIONAL and others, as appropriate, will be scheduled by CITY's Representative to establish a working understanding among the parties as to the Work and to discuss the schedules referred to in Paragraph 2.06 B, procedures for handling Shop Drawings and other submittals, processing Applications for Payment, maintaining required records, Claims process, dispute resolution or any other applicable provisions of the Contract Documents.

2.07 Acceptable Schedules

A. Acceptable schedule: The Contractor shall update and submit to the CITY for review the preliminary schedule within seven (7) Calendar Days after the Notice to Proceed.

1. The CITY shall review and make any necessary comments and/or adjustments to the updated preliminary schedule. The Contractor shall incorporate the CITY's comments and resubmit the updated preliminary schedule within seven (7) Calendar Days from receipt of the CITY's comments.

B. Project Baseline Schedule: The accepted updated preliminary schedule shall be considered the project baseline schedule and shall be used by the CONTRACTOR for planning, scheduling, managing, and executing the Work. The project baseline schedule shall not be changed without the written consent of CITY. The project baseline schedule may be further modified by the Supplemental Conditions.

C. CONTRACTOR's schedule of values will be acceptable to CITY's Representative as to form and substance if it provides a reasonable allocation of the Contract Price to component parts of the Work.

ARTICLE 3 CONTRACT DOCUMENTS : INTENT, AMENDING, REUSE

3.01 Intent

A. The Contract Documents comprise the entire Contract between CITY and CONTRACTOR concerning the Work.

B. It is the intent of the Contract Documents to describe a functionally complete Project (or part thereof) to be constructed in accordance with the Contract Documents. Any Work, materials or equipment that may reasonably be inferred from the Contract Documents or from prevailing custom or trade usage as being required to produce the intended result will be furnished and performed whether or not specifically called for at no additional cost to CITY. Clarifications and interpretations of the Contract Documents shall be issued by DESIGN PROFESSIONAL as provided in Paragraph 9.03.

C. Correlation and intent of documents: The Drawings and Specifications are intended to supplement each other. Any Work shown on the Drawings and not mentioned in the Specifications (or vice versa) shall be as binding and shall be completed the same as if mentioned or shown on both. In the event of conflicts or discrepancies among the Contract Documents, interpretations will be based on the following priorities:

1. Change Orders and Written Amendments
2. Project Baseline Schedule Requirements
3. Approved Shop Drawings
4. Addenda, with those of later date having precedence over those of earlier date
5. The Supplementary Conditions
6. The General Conditions
7. Drawings and Specifications

D. In the case of an inconsistency between Drawings and Specifications, the requirements of the Specifications shall govern. If Drawings are in conflict, larger scale details shall govern over smaller or no-scale Drawings. If Specification sections are in conflict with each other, the conflict shall be resolved by DESIGN PROFESSIONAL in accordance with reasonable interpretation of such documents.

E. The general character of the detailed Work is shown on the Drawings, but minor modifications may be made in the full size or scale details. Where the word "similar" occurs on the Drawings, it shall be used in its general sense and not as meaning identical, and all details shall be worked out in relation to their location and their connection to the other parts of the Work. Where on any Drawings a portion of the Work is drawn out and the remainder is indicated in outline, the parts drawn out shall apply also to all other like portions of the Work. Where ornaments or other details are indicated by starting only, such details shall be continued throughout the courses or parts in which they occur and shall also apply to all other similar parts in the Work, unless otherwise indicated.

3.02 Reference to Standards and Specifications of Technical Societies

A. Reference to standards, specifications, manuals or codes of any technical society, organization or association, or to Laws or Regulations, whether such reference be specific or by implication, shall mean the latest standard, specification, manual, code or Laws or Regulations in effect at the time of opening of Bids (or on the date of CONTRACTOR's proposal if there are no Bids), except as may be otherwise specifically stated in the Contract Documents.

1. No provision of any such standard, specification, manual, code or instruction of Supplier shall be effective to change the duties or responsibilities of CITY, CONTRACTOR or DESIGN PROFESSIONAL, or any of their Subcontractors, Consultants, agents, or employees from those set forth in the Contract Documents, nor shall it be effective to assign to CITY or DESIGN PROFESSIONAL or any of their Consultants, agents or employees any duty or authority to supervise or direct the furnishing or performance of the Work or any duty or authority to undertake responsibility inconsistent with the provisions of the Contract Documents.

3.03 Reporting and Resolving Discrepancies

A. Reporting Discrepancies: If, during the performance of the Work, CONTRACTOR discovers any conflict, error, ambiguity or discrepancy within the Contract Documents or between the Contract Documents and any provision of any Laws or Regulations applicable to the performance of the Work or of any standard, specification, manual, code or any instruction of any Supplier referred to in Paragraph 6.07, CONTRACTOR shall report it immediately to DESIGN PROFESSIONAL in writing. CONTRACTOR shall not proceed with the Work affected thereby (except in an emergency as authorized by Paragraph 6.17) until an amendment or supplement to the Contract Documents has been issued by one of the methods indicated in Paragraph 3.04; provided, however, that CONTRACTOR shall not be liable to CITY or DESIGN PROFESSIONAL for failure to report any such conflict, error, ambiguity or discrepancy unless CONTRACTOR knew or reasonably should have known thereof.

B. Resolving Discrepancies. The provisions of the Contract Documents shall take precedence in resolving any conflict, error, ambiguity or discrepancy between the provisions of the Contract Documents and:

1. the provisions of any standard, specification, manual, code or instruction (whether or not specifically incorporated by reference in the Contract Documents); or
2. the provisions of any Laws or Regulations applicable to the performance of the Work.

3.04 Amending and Supplementing Contract Documents

A. The Contract Documents may be amended to provide for additions, deletions and revisions in the Work or to modify the terms and conditions thereof in one or more of the following ways:

1. a Written Amendment or
2. a Change Order (pursuant to Article 10), whether pursuant to a Work Change Directive or otherwise.

B. The requirements of the Contract Documents may be supplemented and minor variations and deviations in the Work may be authorized, in one or more of the following ways

1. DESIGN PROFESSIONAL's approval of a Shop Drawing or Sample (pursuant to Paragraph 6.18), or
2. DESIGN PROFESSIONAL's written interpretation or clarification (pursuant to Paragraph 9.03).

3.05 Reuse of Documents

A. CONTRACTOR and any Subcontractor or Supplier or other person or organization performing or furnishing any of the Work under this Contract:

1. shall not have or acquire any title to or ownership rights in any of the Drawings, Specifications or other documents (or copies of any thereof) prepared by or bearing the seal of DESIGN PROFESSIONAL or Consultant, and
2. shall not reuse any of such Drawings, Specifications, other documents or copies thereof on extensions of the Project or any other project without written consent of CITY, and of DESIGN PROFESSIONAL or Consultant, as applicable, and specific written verification or adaptation by DESIGN PROFESSIONAL or Consultant.

This prohibition will survive final payment, completion, and acceptance of the Work, or termination or completion of the Contract. Nothing herein shall preclude CONTRACTOR from retaining copies of the Contract Documents for record purposes.

ARTICLE 4 AVAILABILITY OF LANDS; SUBSURFACE AND PHYSICAL CONDITIONS; REFERENCE POINTS

4.01 Availability of Lands

A. CITY shall furnish the Site. CITY shall identify any encumbrances or restrictions not of general application but specifically related to use of lands so furnished with which CONTRACTOR will have to comply in performing the Work. Easements for permanent structures or permanent changes in existing facilities will be obtained and paid for by CITY, unless otherwise provided in the Contract Documents. If CONTRACTOR and CITY are unable to agree on entitlement to or the amount or extent of any adjustments in the Contract Price or the Contract Times or both as a result of any delay in CITY's furnishing these lands, rights-of-way or easements, CONTRACTOR may make a Claim as provided in Article 16. CONTRACTOR shall provide for all additional lands and access thereto that may be required for temporary construction facilities or storage of materials and equipment.

4.02 Subsurface and Physical Conditions

A. Reports and Drawings: Reference is made to the Supplementary Conditions for identification of:

1. Subsurface Conditions: Those reports of explorations and tests of subsurface conditions at or contiguous to the Site that have been utilized by DESIGN PROFESSIONAL in preparing the Contract Documents; and
2. Physical Conditions: Those drawings of physical conditions in or relating to existing surface or subsurface structures at or contiguous to the Site (except Underground Facilities) that have been utilized by DESIGN PROFESSIONAL in preparing the Contract Documents.

B. Limited Reliance by CONTRACTOR on Technical Data Authorized: CONTRACTOR may rely upon the general accuracy of the technical data contained in reports and drawings of subsurface or physical conditions, but such reports and drawings are not Contract Documents. The technical data is identified in the Supplementary Conditions. Except for reliance on such technical data, CONTRACTOR may not rely upon or make any Claim against CITY, DESIGN PROFESSIONAL or any Consultant with respect to:

1. the completeness of such reports and drawings for CONTRACTOR's purposes, including, but not limited to, any aspects of the means, methods, techniques, sequences and procedures of construction to be employed by CONTRACTOR and safety precautions and programs incident thereto; or
2. other data, interpretations, opinions and information contained in such reports or shown or indicated in such drawings, or
3. any CONTRACTOR interpretation of or conclusion drawn from any technical data or any such other data, interpretations, opinions or information.

4.03 Differing Subsurface or Physical Conditions

A. Notice of Differing Subsurface or Physical Conditions. If CONTRACTOR believes that any subsurface or physical condition at or contiguous to the Site that is uncovered or revealed either:

1. is of such a nature as to establish that any technical data on which CONTRACTOR is entitled to rely as provided in Paragraphs 4.02 A and 4.02 B is materially inaccurate; or
2. is of such a nature as to require a change in the Contract Documents; or
3. differs materially from that shown or indicated in the Contract Documents; or
4. is of an unusual nature, and differs materially from conditions ordinarily encountered and generally recognized as inherent in work of the character provided for in the Contract Documents; then CONTRACTOR shall, promptly after becoming aware thereof and before further disturbing the subsurface or physical conditions or performing any Work in connection therewith (except in an emergency as required by Paragraph 6.17), notify CITY and DESIGN PROFESSIONAL in writing about such condition(s). CONTRACTOR shall not further disturb such conditions or perform any Work in connection therewith (except as aforesaid) until receipt of written order to do so.

B. DESIGN PROFESSIONAL's Review: After receipt of notice as required by Paragraph 4.03 A, DESIGN PROFESSIONAL will promptly review the pertinent conditions, determine the necessity for CITY to obtain additional exploration or tests with respect thereto and notify CITY in writing (with a copy to CONTRACTOR) of DESIGN PROFESSIONAL's findings and conclusions.

C. Possible Contract Documents Change: If CITY concludes that a change in the Contract Documents is required as a result of a condition that meets one or more of the categories in Paragraph 4.03 A, a Work Change Directive or a Change Order will be issued as provided in Article 10 to reflect and document the consequences of such change.

D. Possible Price or Times Adjustments: An equitable adjustment in the Contract Price or in the Contract Times, or both, will be allowed to the extent that the existence of a subsurface or physical condition causes an increase or decrease in CONTRACTOR's cost of, or time required for, performance of the Work; subject, however, to the following:

1. the condition must meet any one or more of the categories described in Paragraphs 4.03 A.1 through 4.03 A.4, inclusive;
2. a change in the Contract Documents pursuant to Paragraph 4.03 C will not be an automatic authorization of, nor a condition precedent to, entitlement to any such adjustments;
3. with respect to Work that is paid for on a unit price basis, any adjustment in Contract Price will be subject to the provisions of Paragraphs 9.06 and 11.04; and
4. CONTRACTOR shall not be entitled to any adjustment in the Contract Price or Contract Times if;
 - a. CONTRACTOR knew, or by the exercise of ordinary care could have known, of such conditions at the time CONTRACTOR made a final commitment to CITY with respect to Contract Price and Contract Times by the submission of a Bid; or
 - b. the existence of such condition could reasonably have been discovered or revealed as a result of any examination, investigation, exploration, test or study of the Site and contiguous areas required by the Bidding Requirements or Contract Documents to be conducted by or for CONTRACTOR prior to CONTRACTOR's making such final commitment; or
 - c. CONTRACTOR failed to give the written notice as required by Paragraph 4.03 A.

E. If CITY and CONTRACTOR are unable to agree on entitlement to, or magnitude of, an equitable adjustment in the Contract Price pursuant to Article 11 and/or Contract Times pursuant to Article 12, a Claim may be made therefore as provided in Article 16. However, CITY, DESIGN PROFESSIONAL and Consultants shall not be liable to CONTRACTOR for any costs, losses or damages (including but not limited to all fees and charges of engineers, architects, attorneys, and other professionals and all other dispute resolution costs) sustained by CONTRACTOR on or in connection with any other project or anticipated project.

4.04. Physical Conditions – Underground Facilities

A. Shown or Indicated: The information and data shown or indicated in the Contract Documents with respect to existing Underground Facilities at or contiguous to the Site is based on information and data furnished to CITY or DESIGN PROFESSIONAL by the owners of such Underground Facilities or by others.

1. CITY and DESIGN PROFESSIONAL shall not be responsible for the accuracy or completeness of any such information or data; and
2. The cost of all of the following will be included in the Contract Price and CONTRACTOR shall have full responsibility for:
 - a. reviewing and checking all such information and data,
 - b. locating all Underground Facilities shown or indicated in the Contract Documents,
 - c. coordination of the Work with the owners of such Underground Facilities during construction, and
 - d. the safety and protection of all such Underground Facilities as provided in Paragraph 6.14 and repairing any damage thereto resulting from the Work.

B. Not Shown or Indicated: If an Underground Facility is uncovered or revealed at or contiguous to the Site, and was not shown or indicated in the Contract Documents, or was

shown or indicated incorrectly in the Contract Documents, CONTRACTOR shall, promptly after becoming aware thereof and before further disturbing conditions affected thereby or performing any Work in connection therewith (except in an emergency as required by Paragraph 6.17), identify the owner of such Underground Facility and give written notice to that owner and to CITY and DESIGN PROFESSIONAL.

C. DESIGN PROFESSIONAL's Review: After receipt of notice as required by Paragraph 4.04 B, DESIGN PROFESSIONAL will promptly review the consequences of the existence of the Underground Facility and notify CITY in writing (with a copy to CONTRACTOR) of DESIGN PROFESSIONAL's findings and conclusions.

D. Possible Contract Documents Change: If CITY concludes that a change in the Contract Documents is required as a result of the existence of an Underground Facility that either was not shown, or was shown incorrectly, in the Contract Documents, a Work Change Directive or Change Order will be issued as provided in Article 10 to reflect and document the consequences of such change.

E. Possible Price or Times Adjustments: An equitable adjustment in the Contract Price or in the Contract Times, or both, will be allowed to the extent that the existence of the Underground Facility causes an increase or decrease in CONTRACTOR's cost of, or time required for, performance of the Work; subject, however, to the following:

1. a change in the Contract documents pursuant to Paragraph 4.04 D will not be an automatic authorization of, nor a condition precedent to, entitlement to any such adjustments;
2. with respect to Work that is paid for on a unit price basis, any adjustment in Contract Price will be subject to the provisions of Paragraphs 9.06 and 11.04; and
3. CONTRACTOR shall not be entitled to any adjustment in the Contract Price or Contract Times if;
 - a. CONTRACTOR knew, or by the exercise of ordinary care could have known, of the existence of the Underground Facility at the time CONTRACTOR made a final commitment to CITY with respect to Contract Price and Contract Times by the submission of a Bid; or
 - b. the existence of the Underground Facility could reasonably have been discovered or revealed as a result of any examination, investigation, exploration, test or study of the Site and contiguous areas required by the Bidding Requirements or Contract Documents to be conducted by or for CONTRACTOR prior to CONTRACTOR's making such final commitment; or
 - c. CONTRACTOR failed to give the written notice as required by Paragraph 4.04 B.

F. If CITY and CONTRACTOR are unable to agree on entitlement to, or magnitude of, an equitable adjustment in the Contract Price pursuant to Article 11 and/or Contract Times pursuant Article 12, a Claim may be made therefore as provided in Article 16. However, CITY, DESIGN PROFESSIONAL and Consultants shall not be liable to CONTRACTOR for any costs, losses or damages (including but not limited to all fees and charges of engineers, architects, attorneys, and other professionals and all other dispute resolution costs) sustained by CONTRACTOR on or in connection with any other project or anticipated project.

4.05 Reference Points

A. CITY shall provide engineering surveys to establish reference points for construction that in DESIGN PROFESSIONAL's judgment are necessary to enable CONTRACTOR to proceed with the Work. CONTRACTOR shall be responsible for laying out the Work, shall protect and preserve the established reference points and property monuments, and shall make no changes or relocations without the prior written approval of CITY. CONTRACTOR shall report to DESIGN PROFESSIONAL whenever any reference point or property monument is lost or destroyed or requires relocation because of necessary changes in grades or locations, and shall be

responsible for the accurate replacement or relocation of such reference points or property monuments by professionally qualified personnel.

4.06 Asbestos, Lead-Based Paint, PCBs, Petroleum, Hazardous Waste or Radioactive Material

A. Reports and Drawings: Reference is made to the Supplementary Conditions for the identification of those reports and drawings relating to a Hazardous Environmental Condition identified at the Site, if any, that have been utilized by the DESIGN PROFESSIONAL in the preparation of the Contract Documents.

B. Limited Reliance by CONTRACTOR on Technical Data Authorized: CONTRACTOR may rely upon the general accuracy of the technical data contained in reports and drawings relating to a Hazardous Environmental Condition at the Site, but such reports and drawings are not Contract Documents. Such technical data is identified in the Supplementary Conditions. Except for such reliance on such technical data, CONTRACTOR may not rely upon or make any Claim against CITY, DESIGN PROFESSIONAL or any Consultant with respect to:

1. the completeness of such reports and drawings for CONTRACTOR's purposes, including, but not limited to, any aspects of the means, methods, techniques, sequences and procedures of construction to be employed by CONTRACTOR and safety precautions and programs incident thereto; or
2. other data, interpretations, opinions and information contained in such reports or shown or indicated in such drawings; or
3. any CONTRACTOR interpretation of or conclusion drawn from any technical data or any such other data, interpretations, opinions or information.

C. CONTRACTOR shall not be responsible for any Hazardous Environmental Condition uncovered or revealed at the Site which was not shown or indicated in Drawings or Specifications or identified in the Contract Documents to be within the scope of the Work. CONTRACTOR shall be responsible for all Hazardous Environmental Conditions created with any materials brought to the Site by CONTRACTOR, Subcontractors, Suppliers, or anyone else for whom CONTRACTOR is responsible. CONTRACTOR shall not be entitled to an extension of the Contract Times or an increase in the Contract Price if CONTRACTOR, Subcontractor, Supplier or anyone for whom CONTRACTOR is responsible created any Hazardous Environmental Condition at the Site or in connection with the Work.

D. If CONTRACTOR encounters a Hazardous Environmental Condition at the Site or if CONTRACTOR or anyone for whom CONTRACTOR is responsible creates a Hazardous Environmental Condition at the Site, CONTRACTOR shall immediately:

1. secure or otherwise isolate such condition;
2. stop all Work in connection with such condition and in any area affected thereby (except in an emergency as required by Paragraph 6. 15); and
3. notify CITY and DESIGN PROFESSIONAL (and promptly thereafter confirm such notice in writing). CITY shall promptly consult with DESIGN PROFESSIONAL concerning the necessity for CITY to retain a qualified expert to evaluate such condition or take corrective action, if any.

E. CONTRACTOR shall neither resume Work nor be required to resume Work in connection with such condition or in any affected area until after CITY has obtained any required permits related thereto and delivered to CONTRACTOR written notice:

1. specifying that such condition and any affected area is or has been rendered safe for the resumption of Work; or
2. specifying any special conditions under which such Work may be resumed safely. If CITY and CONTRACTOR cannot agree as to entitlement to or on the amount or extent, if any, of any adjustment in Contract Price pursuant to Article 11 and/or Contract Times to

pursuant to Article 12 as a result of such Work stoppage or such special conditions under which Work is agreed to be resumed by CONTRACTOR, a Claim may be made therefore as provided in Article 16.

F. If after receipt of written notice as required in Paragraph 4.06 E, CONTRACTOR does not agree to resume Work based on a reasonable belief it is unsafe, or does not agree to resume such Work under special conditions specified in the notice, then CITY may order the portion of the Work that is in the area affected by such condition to be deleted from the Work. If CITY and CONTRACTOR cannot agree as to entitlement to or magnitude of an equitable adjustment in Contract Price pursuant to Article 11 and/or Contract Times pursuant to Article 12 as a result of deleting such portion of the Work, then a Claim may be made therefore as provided in Article 16. CITY may have such deleted portion of the Work performed by CITY's own forces or others in accordance with Article 7.

G. The provisions of Paragraphs 4.02, 4.03, and 4.04 are not intended to apply to a Hazardous Environmental Condition uncovered or revealed at the Site.

H. All materials used, whether new or salvaged, shall be asbestos-free materials. CONTRACTOR shall immediately call to the attention of the CITY's Representative any specified material or product which the CONTRACTOR knows or suspects to contain asbestos, whether new or salvaged.

ARTICLE 5 BONDS AND INSURANCE

5.01 Performance, Payment and Other Bonds

A. CONTRACTOR shall furnish Performance and Maintenance and Payment Bonds, each in an amount at least equal to the Contract Price, as set out in the Contract Documents, as security for the faithful performance and payment of all CONTRACTOR's obligations under the Contract Documents. These Bonds shall remain in effect at least until one (1) year after the date when final payment of the Contract becomes due, except as provided otherwise by Laws or Regulations or by the Contract Documents. CONTRACTOR shall also furnish such other Bonds as are required by the Supplementary Conditions.

B. All Bonds shall be in the form prescribed by the Contract Documents except as provided otherwise by Laws or Regulations. A certified copy of the agent's authority to act must accompany all Bonds signed by an agent.

C. If the surety on any Bond furnished by CONTRACTOR is declared bankrupt or becomes insolvent, or its right to do business is terminated in any state where any part of the Project is located or it ceases to meet the requirement of Paragraph 5.01 B, CONTRACTOR shall within twenty (20) days thereafter substitute another Bond and surety, both of which must be acceptable to CITY.

5.02 Licensed Sureties and Insurers

A. All Bonds and insurance required by the Contract Documents to be purchased and maintained by CITY or CONTRACTOR shall be obtained from surety or insurance companies that are duly licensed in the State of Missouri and in the jurisdiction in which the Project is located, if not in Missouri, to issue Bonds or insurance policies for the limits and coverages so required. All surety and insurance companies shall hold an A.M. Best rating of A-, V, or better.

5.03 Certificates of Insurance

A. CONTRACTOR shall deliver to CITY and DESIGN PROFESSIONAL, prior to the start of any Work at the Project Site, properly completed certificates of insurance or other evidence that the required insurance is in full force and effect, in a form acceptable to CITY. The receipt or acceptance of a certificate of insurance that does not incorporate the required terms and coverage shall not constitute a waiver by the City of the insurance requirements contained in the Contract Documents.

B. All policies of insurance (and the certificates or other evidence thereof) required to be purchased and maintained by CONTRACTOR in accordance with Paragraphs 5.04 and 5.06 will contain waiver provisions in accordance with Paragraph 5.07 A. The certificates of insurance will contain a provision stating that should any of the policies described in the certificate be cancelled before the expiration date thereof, notice will be delivered in accordance with the policy provisions.

C. If the coverage afforded is cancelled or changed or its renewal is refused, CONTRACTOR shall give at least thirty (30) days prior written notice to CITY and to each other additional insured to whom a certificate of insurance has been issued.

5.04 CONTRACTOR's Liability Insurance

A. CONTRACTOR shall purchase and maintain such liability and other insurance as is appropriate for the Work being performed and furnished, and will provide protection from claims set forth below which may arise out of or result from CONTRACTOR's performance and furnishing of the Work and CONTRACTOR's other obligations under the Contract Documents, whether it is to be performed or furnished by CONTRACTOR, any Subcontractor or Supplier, or by anyone directly or indirectly employed by any of them to perform or furnish any of the Work, or by anyone for whose acts any of them may be liable:

1. claims under workers' compensation, disability benefits and other similar employee benefit acts;
2. claims for damages because of bodily injury, occupational sickness or disease, or death of CONTRACTOR's employees;
3. claims for damages because of bodily injury, sickness or disease, or death of any person other than CONTRACTOR's employees;
4. claims for damages insured by customary personal injury liability coverage;
5. claims for damages, other than to the Work itself, because of injury to or destruction of tangible property wherever located, including loss of use resulting therefore; and
6. claims for damages because of bodily injury or death of any person or property damage arising out of the ownership, maintenance or use of any motor vehicle.

B. The policies of insurance so required by Paragraph 5.04 A, to be purchased and maintained shall:

1. with respect to insurance required by Paragraphs 5.04 A.3 through 5.04 A.5 inclusive, include as additional insureds (subject to any customary exclusion for professional liability) CITY, DESIGN PROFESSIONAL, Consultants and any other individuals or entities identified in the Supplementary Conditions to be listed as additional insureds, and include coverage for the respective officers, directors, partners, employees, agents, and other consultants and subcontractors of each and any of all such additional insureds, and the insurance afforded to these additional insureds shall provide primary coverage for all claims covered thereby;
2. include at least the specific coverages and be written for not less than the limits of liability provided in Paragraph 5.04 C or required by Laws or Regulations, whichever is greater;
3. include completed operations insurance;
4. include contractual liability insurance covering CONTRACTOR's indemnity obligations;
5. remain in effect at least until final payment and at all times thereafter when CONTRACTOR may be correcting, removing or replacing defective Work in accordance with Paragraphs 13.06 and 13.07;

6. with respect to completed operations insurance, and any insurance coverage written on a claims-made basis, remain in effect for at least two (2) years after final payment (and CONTRACTOR shall furnish CITY and each other additional insured identified in the Supplementary Conditions to whom a certificate of insurance has been issued evidence satisfactory to CITY and any such additional insured of continuation of such insurance);

7. contain a cross-liability or severability of interest clause or endorsement. Insurance covering the specified additional insureds shall be primary insurance, and all other insurance carried by the additional insureds shall be excess insurance;

8. with respect to commercial automobile liability, commercial general liability, and umbrella liability insurance, CONTRACTOR shall require its insurance carrier(s) to waive all rights of subrogation against CITY, and CITY's officers, directors, partners, employees and agents; and

9. contain a provision or endorsement that the costs of providing the insureds a defense and appeal, including attorneys' fees, as insureds, shall be supplementary and shall not be included as part of the policy limits but shall remain the insurer's responsibility.

C. Specific policies of insurance required by this Paragraph 5.04 shall include:

1. Workers' Compensation and Employers' Liability Insurance. This insurance shall protect CONTRACTOR against all claims under applicable state workers' compensation laws, including coverage as necessary for the benefits provided under the United States Longshoremen's and Harbor Workers' Act and the Jones Act. CONTRACTOR shall also be protected against claims for injury, disease, or death of employees which, for any reason, may not fall within the provisions of workers' compensation laws. This policy shall include an "all states" or "other states" endorsement. The liability limits shall be not less than:

Workers' Compensation: Statutory

Employers' liability: \$1,000,000 each occurrence

2. Commercial Automobile Liability Insurance. This insurance shall be occurrence type written in comprehensive form and shall protect CONTRACTOR, and CITY, DESIGN PROFESSIONAL and Consultants against all claims for injuries to members of the public and damage to property of others arising from the use of motor vehicles, either on or off the Project Site, whether they are owned, non-owned, or hired.

The liability limits shall be not less than: \$2,000,000

3. Commercial General Liability Insurance. This insurance shall be occurrence type written in comprehensive form acceptable to CITY. This insurance shall protect CONTRACTOR, and CITY, DESIGN PROFESSIONAL and Consultants as additional insureds, against claims arising from injuries, sickness, disease, or death of any person or damage to property arising out of performance of the Work. The policy shall also include coverage for personal injury liability; contractual liability; completed operations and products liability; and for blasting, explosion, and collapse of buildings; and damage to underground property. The liability limits for bodily injury and property damage shall be not less than:

\$2,000,000 combined single limit for each occurrence

\$2,000,000 general aggregate.

4. The insurer's costs of providing the insureds a defense and appeal as additional insureds, including attorney's fees, shall be supplementary and shall not be included as part of the policy limits but shall remain the insurer's separate responsibility.

5.05 CITY's Liability Insurance

A. In addition to the insurance required to be provided by CONTRACTOR under Paragraph 5.04, CITY, at CITY's option, may purchase and maintain at CITY's expense liability insurance

that will protect CITY against claims which may arise from operations under the Contract Documents.

5.06 Property Insurance

A. Unless otherwise provided in the Supplementary Conditions, CONTRACTOR shall purchase and maintain property insurance on the Work at the Site in the amount of the full replacement cost thereof (subject to such deductible amounts as may be provided in the Supplementary Conditions or required by Laws or Regulations). This insurance shall:

1. include the interests of CITY, CONTRACTOR, Subcontractors, and any other persons or entities identified in the Supplementary Conditions, each of whom is deemed to have an insurable interest and shall be listed as an insured or additional insured;
2. be written on a Builder's Risk "all-risk" or open peril or special causes of loss policy form that shall at least include insurance for physical loss or damage to the Work, temporary buildings, falsework and materials and equipment in transit, and shall insure against at least the following perils or causes of loss: fire, lightning, extended coverage, theft, vandalism and malicious mischief, earthquake, tornado, collapse, debris removal, demolition occasioned by enforcement of Laws or Regulations, water damage, damage caused by frost and freezing, and acts of God;
3. be maintained in effect until final payment is made unless otherwise agreed to in writing by CITY with thirty (30) days written notice to each other additional insured to whom a certificate of insurance has been issued.

B. CITY shall not be responsible for purchasing and maintaining any property insurance to protect the interests of CONTRACTOR, Subcontractors or others involved in the Work to the extent of any deductible amounts. The risk of loss within the deductible amounts will be borne by CONTRACTOR, Subcontractor or others suffering any such loss and if any of them wishes property insurance coverage within the limits of such amounts, each may purchase and maintain it at the purchaser's own expense.

5.07 Waiver of Rights

A. CITY and CONTRACTOR intend that all policies purchased in accordance with Paragraphs 5.04 and 5.06 will protect CITY, CONTRACTOR, DESIGN PROFESSIONAL Consultants, Subcontractors, and all other persons or entities identified in the Supplementary Conditions to be listed as insureds or additional insureds in such policies and will provide primary coverage for all losses and damages caused by the perils covered thereby. All such policies shall contain provisions to the effect that in the event of payment of any loss or damage the insurers will have no rights of recovery against any of the insureds or additional insureds thereunder. CITY and CONTRACTOR waive all rights against each other and their respective officers, directors, partners, employees and agents for all losses and damages caused by, arising out of or resulting from any of the perils covered by such policies and any other property insurance applicable to the Work, but only to the extent of insurance coverage; and, in addition, waive all such rights against DESIGN PROFESSIONAL, Consultants, Subcontractors, and all other persons or entities identified in the Supplementary Conditions to be listed as insureds or additional insureds (and the officers, directors, partners, employees, agents, and other consultants and subcontractors of any and each of them) under such policies for losses and damages so caused and covered by insurance. None of the above waivers shall extend to the rights that any party making such waiver may have to the proceeds of insurance held by CITY as trustee or otherwise payable under any policy so issued. None of the above waivers shall apply if specifically in conflict with Laws and Regulations.

5.08 Receipt and Application of Insurance Proceeds

A. Any insured loss under the property insurance will be adjusted with CITY and made payable to CITY as fiduciary for the insureds, as their interests may appear, subject to the requirements of any indentures of indebtedness entered into by CITY.

B. CITY as fiduciary shall have power to adjust and settle any loss with the insurers unless one of the parties in interest shall object to CITY's exercise of this power in writing within fifteen (15) days after the occurrence of loss. If such objection is made, CITY as fiduciary shall make settlement with the insurers in accordance with such agreement as the parties in interest may reach. If no such agreement among the parties in interest is reached, CITY as fiduciary shall adjust and settle the loss with the insurers.

5.09 Partial Utilization – Property Insurance

A. If CITY finds it necessary to occupy or use a portion or portions of the Work prior to Substantial Completion of all the Work, such use or occupancy may be accomplished in accordance with Paragraph 14.05; provided that no such use or occupancy shall commence before the insurers providing the property insurance have acknowledged notice thereof and in writing effected any changes in coverage necessitated thereby. The insurers providing the property insurance shall consent by endorsement on the policy or policies, but the property insurance shall not be canceled or permitted to lapse on account of any such partial use or occupancy.

ARTICLE 6 CONTRACTOR'S RESPONSIBILITIES

6.01 Indemnification

A. For purposes of this Paragraph 6.01 only, the following terms shall have the meanings listed:

1. Claims means all claims, damages, liability, losses, costs and expenses, including court costs and reasonable attorneys' fees, including attorney's fees incurred by the City in the enforcement of this indemnity obligation.

2. CONTRACTOR'S Agents means CONTRACTOR's officers, employees, sub-consultants, subcontractors, successors, assigns, invitees, and other agents.

3. CITY means CITY, its Program Manager/Construction Advisor and any of their agents, officials, officers, employees and program managers or construction advisors.

B. CONTRACTOR's obligations under this Paragraph with respect to indemnification for acts or omissions, including negligence, of CITY, shall be limited to the coverage and limits of insurance that CONTRACTOR is required to procure and maintain under this Contract. CONTRACTOR affirms that it has had the opportunity to recover the costs of the liability insurance required in this Contract in its contract price.

C. CONTRACTOR shall defend, indemnify and hold harmless CITY from and against all Claims arising out of or resulting from all acts or omissions in connection with this Contract caused in whole or in part by CONTRACTOR or CONTRACTOR's Agents, regardless of whether or not caused in part by any act or omission, including negligence, of OWNER.

D. In any and all Claims against CITY, DESIGN PROFESSIONAL, CONSULTANT, or any of their respective agents, officers, directors or employees by any employee (or the survivor or personal representative of such employee) of CONTRACTOR, any Subcontractor, any Supplier, any person or organization directly or indirectly employed by any of them to perform or furnish any of the Work, or anyone for whose acts any of them may be liable, the indemnification obligation under Paragraph 6.01 C shall not be limited in any way by any limitation on the amount or type of damages, compensation or benefits payable by or for CONTRACTOR or any such Subcontractor, Supplier or other person or organization under workers' compensation acts, disability benefit acts or other employee benefit acts.

E. The indemnification obligations of CONTRACTOR under Paragraph 6.01 C shall not extend to liability arising out of, resulting from, or caused by the professional negligence, errors or omissions of DESIGN PROFESSIONAL, CONSULTANT, or any of their respective agents, officers, directors or employees.

6.02 Supervision and Superintendence

A. CONTRACTOR shall supervise, inspect and direct the Work competently and efficiently, devoting such attention thereto and applying such skills and expertise as may be necessary to perform the Work in accordance with the Contract Documents. CONTRACTOR shall be solely responsible for the means, methods, techniques, sequences and procedures of construction, but CONTRACTOR shall not be responsible for the negligence of others in the design or specification of a specific means, method, technique, sequence or procedure of construction which is shown or indicated in and expressly required by the Contract Documents. CONTRACTOR shall be responsible to see that the completed Work complies accurately with the Contract Documents.

B. At all times during the progress of the Work, CONTRACTOR shall assign a competent resident superintendent of the Work, who shall not be replaced without written request to and approval by CITY except under extraordinary circumstances. The superintendent will be CONTRACTOR's representative at the Site and shall have authority to act on behalf of CONTRACTOR. All communications given to or received from the superintendent shall be binding on CONTRACTOR.

C. If it is determined to be in the best interest of the Work, CONTRACTOR shall replace the project manager, resident superintendent or any other employee of the CONTRACTOR, Subcontractors, Suppliers or other persons or organizations performing or furnishing any of the Work on the project upon written request by the CITY.

6.03 Services, Working Hours, Labor, Materials and Equipment

A. CONTRACTOR shall provide competent, suitably qualified personnel to survey, lay out and construct or perform the Work as required by the Contract Documents. CONTRACTOR shall at all times maintain good discipline and order at the Site. Except as otherwise required for the safety or protection of persons or the Work or property at the Site or adjacent thereto, and except as otherwise indicated in the Contract Documents, all Work at the Site shall be performed during regular working hours. CONTRACTOR shall not permit overtime work or the performance of Work on Saturday, Sunday or any legal holiday without CITY's written consent given after prior written notice to DESIGN PROFESSIONAL.

B. Unless otherwise specified in Division 1, General Requirements, CONTRACTOR shall furnish and assume full responsibility for all services, materials, equipment, labor, transportation, construction equipment and machinery, tools, appliances, fuel, power, light, heat, telephone, water, sanitary facilities, temporary facilities and all other facilities and incidentals necessary for the furnishing, performance, testing, start-up and completion of the Work.

C. All materials and equipment shall be of good quality and new, except as otherwise provided in the Contract Documents. All warranties and guarantees specifically called for by the Specifications shall expressly run to the benefit of CITY. If required by DESIGN PROFESSIONAL, CONTRACTOR shall furnish satisfactory evidence (including reports of required tests) as to the source, kind, and quality of materials and equipment. All materials and equipment shall be stored, applied, installed, connected, erected, used, cleaned and conditioned in accordance with instructions of the applicable Supplier, except as otherwise provided in the Contract Documents.

D. It is the policy of the CITY that any manufactured goods or commodities used or supplied in the performance of this Contract and any subcontract hereto shall be manufactured or produced in the United States whenever possible.

6.04 Progress Schedule

A. CONTRACTOR shall adhere to the progress schedule established in accordance with Article 2 as it may be adjusted from time to time as provided below:

1. CONTRACTOR shall provide, at least once every thirty (30) calendar days, updated information on the project schedule, including thirty (30) day look ahead schedules, projected variances per event category and per Subcontractor, identification of all variances and calculation of the number of Days difference between the as-built critical path and the project schedule critical path

2. CONTRACTOR shall, with each application for payment, provide completed monthly updated status report for the previous month on the project schedule and updated information indicating as-built and as-planned conditions. The updated information on the project schedule shall not modify any Milestone dates in the project schedule that CITY has previously approved. The updated information required is a condition precedent to payment pursuant to paragraph 14.02 and shall include at a minimum:

- a. a concise statement of the outlook for meeting project schedule dates and the reasons for any change in outlook from the previous report;
- b. a review of any significant technical problems encountered during the month;
- c. an explanation of any corrective action taken or proposed; and
- d. a summary of any Claims anticipated by CONTRACTOR with respect to the Work, including the anticipated costs and schedule impacts of any such Claims.

6.05 Recovery Schedules

A. If the CONTRACTOR should:

1. fail, refuse or neglect to supply a sufficient number of workers or to deliver the materials or equipment with such promptness as to prevent the delay in the progress of the Work;
2. fail in any respect to commence and diligently prosecute the Work in accordance with the approved baseline project schedule in order to achieve substantial completion;
3. fail to commence, prosecute, finish, deliver or install the different portions of the Work on time as specified in the approved baseline project schedule; or
4. fail in the performance of any of the material covenants of the Contract Documents;

CITY shall have the right to direct the CONTRACTOR, upon seven (7) calendar days notice, to prepare a written recovery plan, for CITY's approval, to accelerate the Work in order to conform to the approved baseline project schedule, including, without limitation, providing additional labor or expediting delivery of materials, performing overtime or re-sequencing the Work without adjustments to the Contract value. Upon CITY's approval of the recovery plan, CONTRACTOR shall accelerate the Work in accordance with the plan.

B. Proposed recovery schedules shall be submitted to the CITY as a separate project plan for review and approval by CITY prior to incorporation into the approved baseline schedule. The recovery schedule shall be submitted in a format compatible with the baseline schedule format. Each proposed revision shall be submitted as a separate schedule, with the following minimum requirements:

1. A critical path method diagram showing revised and affected activities or Milestones.
2. An activity report for all revised and affected activities or Milestones.

C. Upon acceptance of the recovery schedule by CITY, data shall be added or revised for all new or revised activities and incorporated into the approved baseline project schedule.

6.06 Substitutes and “Or-Equal” Items

A. Materials or equipment: Whenever an item of material or equipment is specified or described in the Contract Documents by using the name of a proprietary item or the name of a particular Supplier, the specification or description is intended to establish the type, function, appearance and quality required. Unless the specification or description contains, or is followed by, words reading that no like, equivalent or “or-equal” item or no substitution is permitted, other items of material or equipment or material or equipment of other Suppliers may be submitted to CITY for review by CITY’s Representative under the following circumstances:

1. “Or-Equal”: If, prior to receipt of Bids, Bidder proposes an item of material or equipment as functionally equal to that named and sufficiently similar so that no change in related Work will be required, CITY’s Representative may request DESIGN PROFESSIONAL to consider it as an “or-equal” item. DESIGN PROFESSIONAL will review and recommend the acceptance, or rejection, of the proposed item to the CITY’s Representative. For the purposes of this Paragraph, a proposed item of material or equipment will be considered functionally equal to an item so named if:

a. in the exercise of reasonable judgment DESIGN PROFESSIONAL determines that:

(1) it is at least equal in quality, durability, appearance, strength, and design characteristics; and

(2) it will reliably perform at least equally well the function imposed by the design concept of the completed Project as a functioning whole; and

b. Bidder certifies that:

(1) there is no increase in cost to the CITY; and

(2) it will conform substantially, even with deviations, to the detailed requirements of the item named in the Contract Documents.

If the CITY’s Representative approves the proposed item, it may be accepted by CITY.

2. Substitute Items: If CONTRACTOR proposes an item of material or equipment as a substitute item, then CONTRACTOR shall submit sufficient information as provided below to allow CITY’s Representative to determine that the item of material or equipment proposed is essentially equivalent to that named and an acceptable substitute therefore. The procedure for review by the CITY’s Representative will include the following as supplemented in the General Requirements and as CITY’s Representative may determine is appropriate under the circumstances:

a. Requests for review of proposed substitute items of material or equipment will not be accepted by CITY’s Representative from anyone other than CONTRACTOR.

b. If CONTRACTOR wishes to furnish or use a substitute item of material or equipment, CONTRACTOR shall first make written application to CITY’s Representative for acceptance thereof.

c. In the application, CONTRACTOR shall certify that the proposed substitute will perform adequately the functions and achieve the results called for by the general design, be similar in substance to that specified and be suited to the same use as that specified. The application will state the extent, if any, to which the evaluation and acceptance of the proposed substitute will impact CONTRACTOR’s achievement of Substantial Completion, whether or not acceptance of the substitute for use in the Work will require a change in any of the Contract Documents (or in the provisions of any other direct contract with CITY for work on the Project) to adapt the design to the proposed substitute and whether or not incorporation or use of the substitute in connection with the Work is subject to payment of any license fee or royalty.

d. All variations of the proposed substitute from that specified will be identified in the application and available maintenance, repair and replacement service will be indicated. The application will also contain an itemized estimate of all costs or credits that will result directly or indirectly from acceptance of such substitute, including costs of redesign and claims of other contractors affected by the resulting change, all of which will be considered by CITY's Representative in evaluating the proposed substitute. CITY's Representative may require CONTRACTOR to furnish additional data about the proposed substitute.

If the CITY's Representative approves the proposed item, CITY may accept it.

B. Substitute Construction Methods or Procedures: If a specific means, method, technique, sequence or procedure of construction is shown or indicated in and expressly required by the Contract Documents, CONTRACTOR may furnish or utilize a substitute means, method, technique, sequence or procedure of construction acceptable to DESIGN PROFESSIONAL. CONTRACTOR shall notify CITY and submit sufficient information to allow DESIGN PROFESSIONAL, in DESIGN PROFESSIONAL's sole discretion, to determine that the substitute proposed is equivalent to that expressly called for by the Contract Documents.

C. Expenses: Bidder shall provide all data in support of any "or equal" at Bidder's expense, and CONTRACTOR shall provide all data in support of any proposed substitute at CONTRACTOR's expense.

D. Evaluation: DESIGN PROFESSIONAL and CITY's Representative will be allowed a reasonable time within which to evaluate each proposal or submittal made pursuant to Paragraphs 6.06 A, and 6.06 B. CITY will be the sole judge of acceptability. No "or-equal" or substitute will be ordered, installed or utilized without CITY's prior written acceptance which will be evidenced by either a Change Order or an approved Shop Drawing. CITY may require CONTRACTOR to furnish at CONTRACTOR's expense, a special performance guarantee or other surety with respect to any "or-equal" substitute. DESIGN PROFESSIONAL will record time required by DESIGN PROFESSIONAL and Consultants in evaluating substitutes proposed or submitted by CONTRACTOR pursuant to Paragraphs 6.06 A and 6.06 B and in making changes in the Contract Documents (or in the provisions of any other direct contract with CITY for work on the Project) occasioned thereby. Whether or not CITY accepts a substitute so proposed or submitted by CONTRACTOR, CONTRACTOR shall reimburse CITY for the reasonable charges of DESIGN PROFESSIONAL and Consultants for evaluating each such proposed substitute.

6.07 Concerning Subcontractors, Suppliers and Others

A. CONTRACTOR shall not employ or retain any Subcontractor, Supplier or other person or organization (including those acceptable to CITY as indicated in Paragraph 6.07 B), whether initially or as a substitute, against whom CITY has a reasonable objection, including but not limited to debarment by City or another governmental entity or decertification of the Subcontractor from the City's Minority and Women's Business Enterprise Program as a result of the Subcontractor's failure to comply with any of the requirements of the provisions of Chapter 3 of the City's Code as determined by the Director of the Civil Rights and Equal Opportunity Department. Contractor shall insert this provision in any subcontractor agreement associated with this Contract. CONTRACTOR shall not be required to employ any Subcontractor, Supplier or other person or organization to furnish or perform any of the Work against whom CONTRACTOR has reasonable objection. CONTRACTOR shall submit required information for all Subcontractors on Form 01290.09 - Subcontractor and Major Material Suppliers List, provided in these Contract Documents, prior to Subcontractor beginning Work at the Site.

B. The Supplementary Conditions require the identity of certain Subcontractors, Suppliers or other persons or organizations (including those who are to furnish the principal items of materials or equipment) to be submitted to CITY on or before the date specified in the Supplementary Conditions, for acceptance by CITY. If CONTRACTOR has submitted a list

thereof in accordance with the Supplementary Conditions, CITY may accept (either in writing or by failing to make written objection thereto by the date indicated for acceptance or objection in the Contract Documents) any such Subcontractor, Supplier or other person or organization so identified, or may reject same on the basis of reasonable objection after due investigation, in which case CONTRACTOR shall submit an acceptable replacement for the rejected Subcontractor, Supplier or other person or organization. The Contract Price will be adjusted by the difference in the cost occasioned by such substitution, and an appropriate Change Order will be issued or Written Amendment signed. No acceptance by CITY of any such Subcontractor, Supplier or other person or organization shall constitute a waiver of any right of CITY or DESIGN PROFESSIONAL to reject defective Work.

C. CONTRACTOR shall be fully responsible to CITY for all acts and omissions of the Subcontractors, Suppliers and other persons and organizations performing or furnishing any of the Work under a direct or indirect contract with CONTRACTOR just as CONTRACTOR is responsible for CONTRACTOR's own acts and omissions. Nothing in the Contract Documents shall create for the benefit of any such Subcontractor, Supplier or other person or organization any contractual relationship between CITY or DESIGN PROFESSIONAL and any such Subcontractor, Supplier or other person or organization, nor shall it create any obligation on the part of CITY or DESIGN PROFESSIONAL to pay or to see to the payment of any moneys due any such Subcontractor, Supplier or other person or organization except as may otherwise be required by Laws or Regulations.

D. CONTRACTOR shall be solely responsible for scheduling and coordinating the Work of Subcontractors, Suppliers and other persons and organizations performing or furnishing any of the Work under a direct or indirect contract with CONTRACTOR.

E. CONTRACTOR shall contractually require all Subcontractors, Suppliers and such other persons and organizations performing or furnishing any of the Work to communicate with CITY and DESIGN PROFESSIONAL through CONTRACTOR.

F. The divisions and sections of the Specifications and the identifications of any Drawings shall not control CONTRACTOR in dividing the Work among Subcontractors or Suppliers or delineating the Work to be performed by any specific trade.

G. All Work performed for CONTRACTOR by a Subcontractor or Supplier shall be pursuant to an appropriate written agreement between CONTRACTOR and the Subcontractor or Supplier that specifically binds the Subcontractor or Supplier to the applicable terms and conditions of the Contract Documents for the benefit of CITY. Whenever any such agreement is with a Subcontractor or Supplier who is listed as an additional insured on the property insurance provided in Paragraph 5.06, the agreement between the CONTRACTOR and the Subcontractor or Supplier will contain provisions whereby the Subcontractor or Supplier waives all rights against CITY, CONTRACTOR, DESIGN PROFESSIONAL, Consultants and all other additional insureds for all losses and damages caused by, arising out of or resulting from any perils, to the extent covered by such policies and any other property insurance applicable to the Work. If the insurers on any such policies require separate waiver forms to be signed by any Subcontractor or Supplier, CONTRACTOR will obtain the same.

H. Except as otherwise provided in this subsection H and in accordance with the provisions of subsection C hereof, the agreement between CONTRACTOR and the Subcontractor or Supplier referred to in subsection G, shall provide that the CONTRACTOR and the Subcontractor or Supplier agree not to request CITY or CITY's Representative to intervene in or facilitate the resolution of claims or contract disputes arising out of or related to the agreement between CONTRACTOR and the Subcontractor or Supplier. Furthermore, the Contracts between CONTRACTOR and Subcontractors or Suppliers shall provide that all unresolved claims and disputes between CONTRACTOR and the Subcontractor or Supplier that remain unresolved after thirty (30) calendar days from the notice of claim, shall be subject to mediation as a condition precedent to the institution of legal proceedings by either party. Any such mediation shall be conducted in accordance with the CITY's Code Section 3-467.

I. CONTRACTOR shall not insert any provision in any subcontractor agreement associated with this Contract that explicitly states or implies that the subcontractor shall only be paid for work performed if or when the general CONTRACTOR is paid by the CITY . Contractor's compliance with this provision is a material term of this Contract.

J. CONTRACTORS shall not deny any Subcontractor subcontracting opportunities solely because the Subcontractor is not a signatory to collective bargaining agreements with organized labor.

6.08 Patent Fees and Royalties

A. CONTRACTOR shall pay all license fees and royalties and assume all costs incident to the use in the performance of the Work or the incorporation into the Work of any invention, design, process, product or device which is the subject of patent rights or copyrights held by others. If a particular invention, design, process, product or device is specified in the Contract Documents for use in the performance of the Work, and if to the actual knowledge of CITY or DESIGN PROFESSIONAL its use is subject to patent rights or copyrights calling for the payment of any license fee or royalty to others, the existence of such rights shall be disclosed by CITY in the Contract Documents. To the fullest extent permitted by Laws or Regulations, CONTRACTOR shall defend, indemnify and hold harmless CITY, DESIGN PROFESSIONAL, Consultants and the officers, directors, employees, agents and other consultants of each and any of them from and against all claims, costs, losses and damages (including but not limited to all fees and charges of engineers, architects, attorneys, and other professionals and all court or arbitration or other dispute resolution costs) arising out of or resulting from any infringement of patent rights or copyrights incident to the use in the performance of the Work or resulting from the incorporation into the Work of any invention, design, process, product or device not specified in the Contract Documents.

6.09 Permits

A. Unless otherwise provided in the Supplementary Conditions, CONTRACTOR shall obtain and pay for all construction permits and licenses. CITY shall assist CONTRACTOR, when necessary, in obtaining such permits and licenses. CONTRACTOR shall pay all governmental charges and inspection fees necessary for the prosecution of the Work, which are applicable at the time of opening of Bids, or, if there are no Bids, on the Effective Date of the Contract. CONTRACTOR shall pay all charges of utility owners for connections to the Work.

B. CONTRACTOR, at its own expense, shall comply with all Federal, State and local laws and regulations, including, but not limited to the Missouri Clean Water Law (Chapter 644 RSMo) together with any accompanying regulation(s) contained in the Missouri Code of State Regulations (CSR Title 10), as well as any implementing permits, together with any CITY Provisions during the life of this Contract including but not limited to:

1. Approvals and permits as required for construction or land disturbance activities.
2. Compliance with the State of Missouri – Department of Natural Resources (“MDNR”) Missouri State Operating Permit (“Land Disturbance Permit”), MO-R100006 for all construction or land disturbance activity.
3. Development and implementation of a Storm Water Pollution Prevention Plan (SWPPP).
 - (a) Contractor shall not commence land disturbance activity until the initial SWPPP has been finalized.
 - (b) Preparation and submittal of all applications, documentation and exhibits required to obtain MDNR approvals for uninterrupted Work at the Site.
 - (c) Amending/Updating SWPPP.
 - (d) Site Inspections and submittal of Inspection Reports

(e) Proper Operation and Maintenance to achieve compliance with the terms of the Permit.

(f) Maintenance of required records in accordance with MDNR requirements and requirements included in Article 6 of these Contract Documents.

4. In addition to requirements of Article 6, Contractor shall also provide record access to Missouri Department of Natural Resources (MDNR).

5. Failure to control erosion and water pollution is a permit violation. CONTRACTOR shall have 24 hours after receiving notice of the violation to correct the problem. If the CONTRACTOR fails to correct the problem after the time prescribed, the City will hire a remediation expert to fix the problem. In such an event, the CONTRACTOR shall be liable to the City for the remediation costs plus a 10% mark-up of the total contract price. If the CONTRACTOR receives three (3) notices of violation of the erosion control plan and the City's MS4 permit, the Director may issue a stop work order and delay any payment until control measures are properly functioning and stream damage has been mitigated. In such an event, any delay to the project schedule will result in liquidated damages assessed against the CONTRACTOR.

6.10 Compliance with Laws and Regulations

A. CONTRACTOR shall comply with all federal, state and local laws, ordinances and regulations applicable to the work and this Contract. CONTRACTOR shall give all notices and comply with all Laws or Regulations applicable to furnishing and performing the Work. Except where otherwise expressly required by applicable Laws or Regulations, neither CITY nor DESIGN PROFESSIONAL shall be responsible for monitoring CONTRACTOR's compliance with any Laws or Regulations. The Laws or Regulations included in this Paragraph shall include, but not be limited to, those set forth in the Supplementary Conditions.

B. Failure to Comply. If CONTRACTOR performs any Work in violation of applicable Laws or Regulations, CONTRACTOR shall bear all claims, costs, losses and damages (including but not limited to all fees and charges of engineers, architects, attorneys, and other professionals and all court or arbitration or other dispute resolution costs) caused by, arising out of or resulting therefrom; however, it shall not be CONTRACTOR's primary responsibility to make certain that the Specifications and Drawings are in accordance with Laws or Regulations, but this shall not relieve CONTRACTOR of CONTRACTOR's obligations under Paragraph 3.03.

C. Conflicts of Interest. The provisions of City's Code Sections 2-2001 and 3-301, prohibiting City officers and employees from having a financial or personal interest in any contract with City, and Code Sections 3-307, and 3-309, imposing sanctions for violations, shall apply to this Contract. CONTRACTOR certifies that no officer or employee of City has, or will have, a direct or indirect financial or personal interest in this Contract, and that no officer or employee of City, or member of such officer's or employee's immediate family, either has negotiated, or has or will have an arrangement concerning employment to perform services on behalf of CONTRACTOR on this Contract.

D. Licenses and Permits. CONTRACTOR, at its own expense, shall secure or cause to be secured all licenses and permits from public or private sources necessary for the fulfillment of its obligations under this Contract. All references in this Contract to the "Code" shall mean City's Code of Ordinances, including any amendments thereto or re-codification thereof unless the context clearly indicates otherwise. CONTRACTOR shall obtain copies of all necessary licenses and permits from Subcontractors required for the Work before Subcontractors begin Work at the Site. CONTRACTOR shall retain such evidence in its files and make available to CITY within ten (10) days after CITY's written request.

E. Americans with Disabilities Act. CONTRACTOR agrees to comply, during the course of this Contract, with all provisions of Title II of the 2010 ADA Standards for Accessible Design as amended from time to time.

F. Affirmative Action. If the Contract Price exceeds \$300,000.00 and CONTRACTOR employs fifty (50) or more people, CONTRACTOR shall comply with City's Affirmative Action requirements in accordance with the provisions of Chapter 3 of City's Code, the rules and regulations relating to those sections, and any additions or amendments thereto. CONTRACTOR shall not discriminate against any employee or applicant for employment because of race, color, sex, religion, national origin or ancestry, disability, sexual orientation, gender identity or age in a manner prohibited by Chapter 3 of City's Code.

CONTRACTOR shall:

1. Submit, in print or electronic format, a copy of CONTRACTOR'S current certificate of compliance to the City's Civil Rights and Equal Opportunity Department (CREO) prior to receiving the first payment under the contract, unless a copy has already been submitted to CREO at any point within the previous two calendar years. If, and only if, CONTRACTOR does not possess a current certification of compliance, CONTRACTOR shall submit, in print or electronic format, a copy of its affirmative action program to CREO prior to receiving the first payment under the contract, unless a copy has already been submitted to CREO at any point within the previous two calendar years.

2. Require any Subcontractor awarded a subcontract exceeding \$300,000.00 to affirm that Subcontractor has an affirmative action program in place and will maintain the affirmative action program in place for the duration of the subcontract.

3. Obtain from any Subcontractor awarded a subcontract exceeding \$300,000.00 a copy of the Subcontractor's current certificate of compliance and tender a copy of the same, in print or electronic format, to CREO within thirty (30) days from the date the subcontract is executed. If, and only if, Subcontractor does not possess a current certificate of compliance, CONTRACTOR shall obtain a copy of the Subcontractor's affirmative action program and tender a copy of the same, in print or electronic format, to CREO within thirty (30) days from the date the subcontract is executed.

City has the right to take action as directed by City's Civil Rights and Equal Opportunity Department to enforce this provision. If CONTRACTOR fails, refuses or neglects to comply with the provisions of Chapter 3 of City's Code, then such failure shall be deemed a total breach of this Contract and this Contract may be terminated, canceled or suspended, in whole or in part, and CONTRACTOR may be declared ineligible for any further contracts funded by City for a period of one (1) year. This is a material term of this Contract.

G. Minority and Women Business Enterprises and Workforce. City is committed to ensuring that minorities and women participate to the maximum extent possible in the performance of City's construction contracts. If minority and women business enterprise (M/WBE) goals have been set for this Contract, CONTRACTOR agrees to comply with all requirements of City's Minority and Women's Business Enterprise Program as enacted in City's Code, Sections 3-421 through 3-469 and as hereinafter amended. CONTRACTOR shall meet or exceed both the MBE and WBE goals set forth in its Contractor Utilization Plan/Request for Waiver. If workforce utilization goals are applicable to this Contract, CONTRACTOR agrees to comply with all requirements of City's Construction Employment Program as enacted in City's Code, Sections 3-501 through 3-527 and as hereinafter amended. CONTRACTOR shall meet or exceed the construction employment goals unless the same shall have been waived in the manner provided by law. CONTRACTOR's compliance with this provision is a material part of this Contract.

H. Records.

1. For purposes of this section:

(a) "City" shall mean the City Auditor, the City's Internal Auditor, the City's Director of Civil Rights and Equal Opportunity, the City Manager, the City department administering this Contract and their delegates and agents.

(b) "Record" shall mean any document, book, paper, photograph, map, sound recordings or other material, regardless of physical form or characteristics, made or received in connection with this Contract and all Contract amendments and renewals.

2. CONTRACTOR shall maintain and retain all Records for a term of five (5) years that shall begin after the expiration or termination of this Contract and all Contract amendments. City shall have a right to examine or audit all Records and CONTRACTOR shall provide access to City of all records upon ten (10) days written notice from the City.

I. Prevailing Wage.

1. CONTRACTOR shall comply and require its Subcontractors to comply with;

a. sections 290.210 to 290.340, RSMO the State of Missouri Prevailing Wage Law (the "Law"); and

b. 8 CSR 30-3.010 to 8 CSR 30-3.060, the Prevailing Wage Law Rules (the "Rules"); and

c. the Annual Wage Order (Wage Order) issued by the State of Missouri's Department of Labor and Industrial Relations; and

d. any applicable Annual Incremental Wage Increase (Wage Increase) to the Annual Wage Order.

2. The Law, Rules, Annual Wage Order and any Wage Increase are incorporated into and made part hereof this Contract and shall be collectively referred to in this Section as the "Prevailing Wage Requirements."

3. CONTRACTOR shall pay and require its Subcontractors to pay to all workers performing work under this Contract not less than the prevailing hourly rate of wages for the class or type of work performed by the worker in accordance with the Law, Rules, Wage Order and any applicable Wage Increase. CONTRACTOR shall take whatever steps are necessary to insure that the prevailing hourly wage rates are paid and that all workers for CONTRACTOR and each of its Subcontractors are paid for the class or type of work performed by the worker in accordance with the Prevailing Wage Requirements. If CONTRACTOR shall fail to start to perform CONTRACTOR's obligations under the Contract Documents within sixty (60) days from the Effective Date of the Contract, CONTRACTOR and each of its subcontractors shall be obligated to pay all workers in accordance with any new Wage Order, as subsequently amended by any applicable Wage Increase, issued by the Department of Labor and Industrial Relations within the aforementioned sixty (60) day period. The new Wage Order and any applicable Wage Increase shall govern notwithstanding the fact that the Wage Order being replaced might be physically attached or incorporated in the Contract Documents.

4. Prior to each of its Subcontractors beginning Work on the Site, CONTRACTOR shall require each Subcontractor to complete CITY's Form 00490 entitled "Pre-contract Certification" that sets forth the Subcontractor's prevailing wage and tax compliance history for the two (2) years prior to the bid. CONTRACTOR shall retain one (1) year and make the Pre-contract Certifications available to CITY within five (5) days after written request.

5. CONTRACTOR shall:

a. Keep and require each of its Subcontractors engaged in the construction of public works in performance of the Contract to keep full and accurate records on City's "Daily Labor Force Report" Form indicating the worker's name, occupational title or classification group & skill and the workers' hours. City shall furnish blank copies of the Daily Labor Force Report Form to Contractor for its use and for distribution to Subcontractors. Contractor shall submit its and its Subcontractors Daily Labor Force Reports to City each day; and

b. Submit, and require each of its Subcontractors engaged in the construction of public works in performance of the Contract to submit electronically, in a format prescribed by the City, Certified Payroll Report Information indicating the worker's name, address, social security number, occupation(s), craft(s) of every worker employed in connection with the public work together with the number of hours worked by each worker and the actual wages paid in connection with the Project and other pertinent information as requested by the City; and

c. Submit, and require each of its Subcontractors engaged in the construction of public works in performance of the Contract to submit, electronically, in format prescribed by the City, a Payroll Certification. The Payroll Certification must be signed by the employee or agent who pays or supervises the payment of the workers employed under the Contract for the Contractor and each Subcontractor; and

d. The Daily Labor Force Report, documents used to compile information for the Certified Payroll Report, and Payroll Certification are collectively referred to in this Section as the "Records."

6. CONTRACTOR shall submit its and its Subcontractors Daily Labor Force Reports to CITY each day. CONTRACTOR shall make all of CONTRACTOR's and Subcontractors' Records open to inspection by any authorized representatives of OWNER and the Missouri Department of Labor and Industrial Relations at any reasonable time and as often as they may be necessary and such Records shall not be destroyed or removed from the State of Missouri for a period of one (1) year following the completion of the public work in connection with which the Records are made. CONTRACTOR shall have its and its Subcontractors Certified Payroll Reports and Payroll Certifications available at the CONTRACTOR's office and shall provide the Records to the City electronically at City's sole discretion. In addition, all Records shall be considered a public record and CONTRACTOR shall provide the Records to the CITY in the format required by the CITY within three (3) working days of any request by CITY at the CONTRACTOR's cost. CITY, in its sole discretion, may require CONTRACTOR to send any of the Records directly to the person who requested the Record at CONTRACTOR's expense.

7. CONTRACTOR shall post and keep posted a clearly legible statement of all prevailing hourly wage rates to be paid to all workers employed by CONTRACTOR and each of its Subcontractors in the performance of this Contract in a prominent and easily accessible place at the Site of the Work by all workers.

8. If the Contract Price exceeds \$250,000.00, CONTRACTOR shall and shall require each Subcontractor engaged in any construction of public works to have its name, acceptable abbreviation or recognizable logo and the name of the city and state of the mailing address of the principal office of the company, on each motor vehicle and motorized self-propelled piece of equipment which is used in connection with the Project during the time the CONTRACTOR or Subcontractor is engaged on the project. The sign shall be legible from a distance of twenty (20') feet, but the size of the lettering need not be larger than two (2") inches. In cases where equipment is leased or where affixing a legible sign to the equipment is impractical, the CONTRACTOR may place a temporary stationary sign, with the information required pursuant to this section, at the main entrance of the Project in place of affixing the required information on the equipment so long as such sign is not in violation of any state or federal statute, rule or regulation. Motor vehicles which are required to have similar information affixed thereto pursuant to requirements of a regulatory agency of the state or federal government are exempt from the provisions of this subsection.

9. CONTRACTOR must correct any errors in CONTRACTOR's or any Subcontractors' Records, or CONTRACTOR's or any Subcontractors' violations of the Law, Rules, Annual Wage Order and any Wage Increase within fourteen (14) calendar days after notice from CITY.

10. CONTRACTOR shall and shall require its Subcontractors to cooperate with the CITY and the Department of Labor and Industrial Relations in the enforcement of this Section, the Law, Rules, Annual Wage Order and any Wage Increase. Contractor shall and shall require its Subcontractors to permit CITY and the Department of Labor and Industrial Relations to interview any and all workers during working hours on the Project at CONTRACTOR's sole cost and expense.

11. CONTRACTOR shall file with CITY, upon completion of the Project and prior to final payment therefore, affidavits from CONTRACTOR and each of its Subcontractors, stating that each has fully complied with the provisions and requirements of the Missouri Prevailing Wage Law. CITY shall not make final payment until the affidavits, in proper form and order, from CONTRACTOR and each of its Subcontractors, are filed by CONTRACTOR.

12. CONTRACTOR shall forfeit as a statutory penalty to the CITY one hundred dollars (\$100.00) for each worker employed, for each calendar day, or portion thereof, such worker is paid less than the prevailing hourly rates for any work done under this Contract, by CONTRACTOR or by any of CONTRACTOR's Subcontractors. If CONTRACTOR or any of its Subcontractors have violated any section(s) of 290.210 to 290.340, RSMo, in the course of the execution of the Contract, CITY shall when making payments to the CONTRACTOR becoming due under this Contract, withhold and retain therefrom all sums and amounts due and owing as a result of any violation of sections 290.210 to 290.340, RSMo.

J. Prevailing Wage Damages. CONTRACTOR acknowledges and agrees that, based on the experience of CITY, violations of the Missouri Prevailing Wage Act, whether by CONTRACTOR or its Subcontractors, commonly result in additional costs to CITY. CONTRACTOR agrees that additional costs to CITY for any particular violation are difficult to establish and include but are not limited to: costs of construction delays, additional work for CITY, additional interest expenses, investigations, and the cost of establishing and maintaining a special division working under the City Manager to monitor prevailing wage compliance.

1. In the event of the failure by CONTRACTOR or any of its Subcontractors to pay wages as provided in the Missouri Prevailing Wage Act, CITY shall be entitled to deduct from the Contract Price, and shall retain as liquidated damages, one hundred dollars (\$100.00) per day, per worker who is paid less than the prevailing hourly rate of wages, to approximate the additional costs. The sum shall be deducted, paid or owed whether or not the Contract Times have expired.

2. CITY shall give written notice to CONTRACTOR setting forth the workers, who have been underpaid, the amount of the statutory penalty and the amount of the liquidated damages as provided for in this Subparagraph J. CONTRACTOR shall have fourteen (14) calendar days to respond, which time may be extended by CITY upon written request. If CONTRACTOR fails to respond within the specified time, the CITY's original notice shall be deemed final. If CONTRACTOR responds to CITY's notice, CITY will furnish CONTRACTOR a final decision in writing within five (5) days of completing any investigation.

K. Missouri Secretary of State Business Entity Registration. CONTRACTOR shall obtain from all Subcontractors for the Project, a copy of their current certificate of good standing or fictitious name registration from the Missouri Secretary of State before they begin work on the Site. CONTRACTOR shall retain such documents in its files and make available to CITY within ten (10) days after written request.

L. Tropical Hardwoods. The provisions of Code Section 2-1872, restricting the use of tropical hardwoods, shall apply to this Contract.

M. Preference for Missouri Products. Pursuant to Section 71.140 RSMo., preference shall be given to materials, products, supplies and all other articles produced, manufactured, made or grown within the State of Missouri.

N. Guidelines for Open Excavations.

1. CONTRACTOR shall restore required excavations to the level of the adjacent surfaces as soon as practicable. Unsupervised open excavations on public properties are discouraged at all times. If CONTRACTOR, in performance of the Work, makes or causes to be made any excavation in, upon, under, through or adjoining any street, sidewalk, alley, park, boulevard, parkway or any other public properties, and shall leave any part or portion thereof open, CONTRACTOR shall provide effective protection to the public.

2. CONTRACTOR shall protect and secure all excavations in roadways in compliance with existing federal, state and local codes and standards, including, but not limited to the most current edition of the Manual of Uniform Traffic Control Devices. CONTRACTOR shall protect and secure all unsupervised excavations not within roadways, either by covering or fencing.

a. Covering. A protective cover that can sustain the weight of persons or of objects that are placed upon it may be installed over an unsupervised excavation. The cover shall be secured to the ground to prevent movement. Protective covers shall have no opening(s) or protuberance(s) of sufficient size to cause a fall and/or injury. Advance warning devices shall be installed as necessary.

b. Fencing. Fencing to prevent entry may be installed surrounding an unsupervised excavation not protectively covered in its entirety. The fencing shall be a minimum of 42" in height. The fencing shall be constructed in such a manner that it is adequately secured and will remain upright at all times under normal Site conditions. All protective coverings and fences over and around excavations shall be inspected at least daily to assure integrity. Protective coverings and/or fences in heavily trafficked areas shall be inspected more often as necessary.

O. Notification of Utilities. CONTRACTOR shall adhere to the provisions of Sections 319.010 et seq., RSMo., which requires that a person or firm making an excavation in any public street, road or alley, right of way dedicated to public use, utility easement of record, or within any private street or private property do so only after giving notice to, and obtaining information from, owners of Underground Facilities. The 24-hour, toll-free accident prevention hotline number in Missouri is 1-800-344-7483 (1-800-Digrite).

P. Employee Eligibility Verification. CONTRACTOR shall adhere to the provisions of Sections 285.525 et seq., RSMo., which requires that for any contract exceeding five thousand dollars (\$5,000.00), CONTRACTOR shall execute and submit an affidavit, in a form prescribed by CITY, affirming that CONTRACTOR does not knowingly employ any person in connection with the contracted services who does not have the legal right or authorization under federal law to work in the United States as defined in 8 U.S.C. § 1324a(h)(3). CONTRACTOR shall attach to the affidavit documentation sufficient to establish CONTRACTOR'S enrollment and participation in an electronic verification of work program operated by the United States Department of Homeland Security (E-Verify) or an equivalent federal work authorization program operated by the United States Department of Homeland Security to verify information of newly hired employees, under the Immigration Reform and Control Act of 1986. CONTRACTOR may obtain additional information about E-Verify and enroll at <https://e-verify.uscis.gov/enroll/StartPage.aspx?JS=YES>. For those Contractors enrolled in E-Verify, the first and last pages of the E-Verify Memorandum of Understanding that CONTRACTOR will obtain upon successfully enrolling in the program shall constitute sufficient documentation for purposes of complying with this Section. CONTRACTOR shall submit the affidavit and attachments to CITY prior to execution of the Contract, or at any point during the term of the Contract if requested by City.

Q. OSHA 10-Hour Training Requirement. CONTRACTOR and any subcontractor working under this Contract shall require every employee on the Site to complete a ten-hour construction safety program which meets the requirements of Section 292.675, RSMo, except for those employees who shall have previously completed the required program and hold documentation to that effect. CONTRACTOR shall remove or require the removal of any

person from the Site who is subject to this requirement and who does not complete or is unable to produce documentation of their successful completion of the required program within the time limitations prescribed by Section 292.675, RSMo. CONTRACTOR shall forfeit the sum of two thousand five hundred dollars (\$2,500.00), in addition to one hundred dollars (\$100.00) per employee each calendar day, or portion thereof, the employee(s) shall continue to be employed without having completed the required program within the time limitations prescribed by Section 292.675, RSMo. CITY shall be entitled to withhold and retain any amounts due and owing hereunder when making payment to CONTRACTOR.

R. Clean Air Act and Clean Water Act. CONTRACTOR shall comply with requirements of the Clean Air Act (42 U.S.C. 7401 *et seq.*); Clean Water Act (33 U.S.C. 1251 *et seq.*), Missouri Clean Water Law (Chapter 644 RSMo), Code of Federal regulations (Title 40: Protection of Environment, Title 33: Navigation and Navigable Waters) and the rules of the Missouri Code of State Regulations (CSR Title 10).

S. Contract information Management System. If applicable, CONTRACTOR shall comply with CITY's Contract Information Management System requirements. CONTRACTOR shall use CITY's Internet web based Contract Information Management System/Project Management Communications Tool provided by CITY and protocols included in that software during the term of this Contract. CONTRACTOR shall maintain user applications to CITY's provided system for all personnel, subcontractors or suppliers as applicable and shall require subcontractors/subconsultants to maintain same.

T. Anti-Discrimination Against Israel. If this Contract exceeds \$100,000.00 and CONTRACTOR employs at least ten employees, pursuant to Section 34.600, RSMo., by executing this Contract, CONTRACTOR certifies it is not currently engaged in and shall not, for the duration of this contract, engage in a boycott of goods or services from the State of Israel; companies doing business in or with Israel or authorized by, licensed by, or organized under the laws of the State of Israel; or persons or entities doing business in the State of Israel.

U. Ban the Box in Hiring and Promotion

- a. Pursuant to Section 38-104, City Code Ordinances, CONTRACTOR shall not base a hiring or promotional decision on an applicant's criminal history or sentence related thereto, unless the employer can demonstrate that the employment-related decision was based on all information available including consideration of the frequency, recency and severity of a criminal record and that the record was reasonably related to the duties and responsibilities of the position.
- b. Notwithstanding subsection (a), CONTRACTOR may inquire about an applicant's criminal history after it has been determined that the individual is otherwise qualified for the position, and only after the applicant has been interviewed for the position. Any such inquiry may be made of all applicants who are within the final selection pool of candidates from which a job will be filled.
- c. This provision shall not apply to positions where employers are required to exclude applicants with certain criminal convictions from employment due to local, state or federal law or regulation.

V. Title VI of the Civil Rights Act of 1964

- a. Title VI of the Civil Rights Act of 1964 requires that no person in the United States shall, on the grounds of race, color, or national or origin (including limited English proficient individuals), be excluded from participation in, be denied the benefits of, or be subjected to discrimination under any program or activity receiving federal financial assistance. The City of Kansas City, Missouri requires compliance with the requirements of Title VI in all of its programs and activities regardless of the funding source.

- b. CONTRACTOR shall not discriminate on the grounds of race, color, or national or origin (including limited English proficient individuals).

W. Non-discrimination in Employment

CONTRACTOR shall not discriminate against any employee or candidate for employment on the basis of an individual's race, hair texture or hair style associated with an individual's race, color, sex, religion, national origin, or ancestry, disability, sexual orientation, gender identity or age in a manner prohibited by Chapter 38 of the City Code. CONTRACTOR shall not engage in any discrimination as prohibited by Chapter 3 of the City Code.

X. Quality Services Assurance Act

If this Contract exceeds \$160,000.00, CONTRACTOR certifies that CONTRACTOR will pay all employees who will work on this Contract in the city limits of Kansas City, Missouri at least \$15.00 per hour in compliance with the City's Quality Services Assurance Act, Section 3-66, Code of Ordinances unless City has granted CONTRACTOR an exemption pursuant to the Quality Services Assurance Act.

6.11 Taxes

A. CONTRACTOR shall pay all sales, consumer, use and other similar taxes required to be paid by CONTRACTOR in accordance with the Laws or Regulations of the place of the Project which are applicable during the performance of the Work.

B. Tax Compliance.

1. As a condition precedent to CITY making its first payment to CONTRACTOR under this Contract, CONTRACTOR shall furnish to CITY sufficient proof from City's Commissioner of Revenue, dated not more than one (1) year prior to the date provided to CITY, verifying that CONTRACTOR is in compliance with the license and tax ordinances administered by City's Revenue Division of the Finance Department.

2. As a condition precedent to Subcontractors performing any Work under this Contract, CONTRACTOR shall obtain from Subcontractor sufficient proof from City's Commissioner of Revenue, dated not more than one (1) year before the date Subcontractor begins Work, verifying that the Subcontractor is in compliance with the license and tax ordinances administered by City's Revenue Division of the Finance Department. CONTRACTOR shall retain such documentation in its files and make available to CITY within ten (10) days after a written request.

3. As a condition precedent to CITY making final payment under this Contract, if this Contract is longer than one (1) year and exceeds the dollar threshold established by ordinance and included in the Supplementary Conditions, CONTRACTOR shall furnish to CITY sufficient proof from City's Commissioner of Revenue, dated not more than one (1) year before the filing of a final Application for Payment, verifying that CONTRACTOR is in compliance with the license and tax ordinances administered by City's Revenue Division of the Finance Department.

4. If this Contract is longer than one (1) year and exceeds the dollar threshold established by ordinance and included in the Supplementary Conditions, CONTRACTOR shall obtain from Subcontractors sufficient proof from City's Commissioner of Revenue, dated not more than one (1) year before the date of CONTRACTOR's final payment to the Subcontractor, that the Subcontractor was or is in compliance with the license and tax ordinances administered by City's Revenue Division of the Finance Department. CONTRACTOR shall retain such documentation in its files and make available to CITY within ten (10) days after written request.

5. If, at the time of final payment to CONTRACTOR, CONTRACTOR is unable to obtain from all its Subcontractors, if any, and furnish to CITY sufficient proof from City's Commissioner of Revenue that all its Subcontractors are in compliance with the license and tax ordinances administered by City's Revenue Division of the Finance Department, CITY may approve final payment to CONTRACTOR if CITY determines that CONTRACTOR has made a good faith effort to furnish evidence or that there are other extenuating circumstances which make it impossible for CONTRACTOR to furnish sufficient proof.

C. Missouri Sales Tax Exemption. Pursuant to Section 144.062, RSMo, CITY is a Missouri exempt entity and tangible personal property to be incorporated or consumed in the construction of this Project may be purchased without sales tax. CITY shall furnish CONTRACTOR a Missouri Project Exemption Certificate for Sales Tax at the time of issuance of the Notice to Proceed.

6.12 Use of Site and Other Areas

A. CONTRACTOR shall confine construction equipment, the storage of materials and equipment, and the operations of workers to the Site and other areas identified in and permitted by the Contract Documents and other areas permitted by Laws or Regulations. CONTRACTOR shall not unreasonably encumber the Site and the other areas with construction equipment or other materials or equipment. CONTRACTOR shall assume full responsibility for any damage to the Site or the other areas, or to the owner or occupant thereof, or of any adjacent land or areas, resulting from the performance of the Work.

B. Should any claim be made by any such owner or occupant because of the performance of the Work, CONTRACTOR shall promptly settle with such other party by negotiation or otherwise resolve the claim by arbitration or other dispute resolution proceeding or at law. In case of a failure on the part of the CONTRACTOR to restore such property or to make good such damage or injuries, the CITY may, upon forty-eight (48) hours written notice to the CONTRACTOR, repair, rebuild or otherwise restore such property as the CITY may deem necessary, and the cost thereof will be deducted from any moneys due or which may become due the CONTRACTOR under this Contract.

C. CONTRACTOR shall, to the fullest extent permitted by Laws or Regulations, defend, indemnify and hold harmless CITY, DESIGN PROFESSIONAL, Consultants and the officers, directors, employees, agents and other consultants of each and any of them from and against all claims, costs, losses and damages (including but not limited to all fees and charges of engineers, architects, attorneys, and other professionals and all court or arbitration or other dispute resolution costs) arising out of or resulting from any claim or action, legal or equitable, brought by any such owner or occupant against CITY, DESIGN PROFESSIONAL or any other party indemnified hereunder to the extent caused by or based upon CONTRACTOR's performance of the Work.

D. During the progress of the Work, CONTRACTOR shall keep the Site and the other areas free from accumulations of waste materials, rubbish and other debris resulting from the Work. At the completion of the Work CONTRACTOR shall remove all waste materials, rubbish and debris from Site and other areas as well as all tools, appliances, construction equipment and machinery and surplus materials. CONTRACTOR shall leave the Site clean and ready for utilization or occupancy by CITY at Substantial Completion of the Work. CONTRACTOR shall restore to all property not designated for alteration by the Contract Documents to its pre-Work condition.

E. CONTRACTOR shall not load nor permit any part of any structure to be loaded in any manner that will endanger the structure, nor shall CONTRACTOR subject any part of the Work or adjacent property to stresses or pressures that will endanger it.

6.13 Record Documents

A. CONTRACTOR shall maintain in a safe place at the Site one record copy of all Drawings, Specifications, Addenda, the Contract, Written Amendments, Change Orders, Work

Change Directives, and written interpretations and clarifications in good order and annotated to show all changes made during construction. These record documents, together with all approved Samples and a counterpart of all approved Shop Drawings, will be available to CITY and DESIGN PROFESSIONAL for reference. Upon completion of the Work, these record documents, Samples and Shop Drawings will be delivered to DESIGN PROFESSIONAL for CITY.

6.14 Safety and Protection

A. CONTRACTOR shall be solely responsible for initiating, maintaining and supervising all safety precautions and programs in connection with the Work. CONTRACTOR shall comply with all applicable Laws or Regulations relating to the safety of persons or property to protect them from damage, injury or loss; and shall erect and maintain all necessary safeguards for safety and protection. CONTRACTOR shall deliver to CITY a copy of CONTRACTOR'S Health and Safety Plan as provided in the Notice of Intent to Contract.

B. CONTRACTOR shall notify owners of adjacent property and of Underground Facilities and other utility owners when prosecution of the Work may affect them, and shall cooperate with them in the protection, removal, relocation and replacement of their property. All damage, injury or loss to any property referred to in Paragraph 6.14 B.2 or 6.14 B.3 caused, directly or indirectly, in whole or in part, by CONTRACTOR, any Subcontractor, Supplier or any other person or organization directly or indirectly employed by any of them to perform or furnish any of the Work or anyone for whose acts any of them may be liable, shall be remedied by CONTRACTOR (except damage or loss attributable to the fault of Drawings or Specifications or to the acts or omissions of CITY, DESIGN PROFESSIONAL, Consultant, or anyone employed by any of them or anyone for whose acts any of them may be liable, and not attributable, directly or indirectly, in whole or in part, to the fault or negligence of CONTRACTOR, Subcontractor, Supplier or other person or organization directly or indirectly employed by any of them). CONTRACTOR's duties and responsibilities for safety and for protection of the Work shall continue until such time as all the Work is completed and DESIGN PROFESSIONAL has issued a notice to CONTRACTOR in accordance with Paragraph 14.07 that the Work is acceptable (except as otherwise expressly provided in connection with Substantial Completion). CONTRACTOR shall take all necessary precautions for the safety of, and shall provide the necessary protection to prevent damage, injury or loss to:

1. all persons on the Site or who may be affected by the Work;
2. all the Work and materials and equipment to be incorporated therein, whether in storage on or off the Site; and
3. other property at the Site or adjacent thereto, including trees, shrubs, lawns, walks, pavements, roadways, structures, utilities and Underground Facilities not designated for removal, relocation or replacement in the course of the Work.

6.15 Safety Representative

A. In accordance with OSHA standards, CONTRACTOR shall designate a qualified and experienced safety representative whose duties and responsibilities shall be the prevention of accidents and the maintaining and supervising of safety precautions and programs. CONTRACTOR's safety representative shall remain at the Site whenever there is Work in progress and shall immediately notify CITY of any emergencies or accidents occurring at the Site

6.16 Hazard Communication Programs

A. CONTRACTOR shall be responsible for coordinating any exchange of material safety data sheets or other hazard communication information required to be made available to or exchanged between or among employers at the Site in accordance with Laws or Regulations.

6.17 Emergencies

A. In emergencies affecting the safety or protection of persons or the Work or property at the Site or adjacent thereto, CONTRACTOR, without special instruction or authorization from CITY or DESIGN PROFESSIONAL, is obligated to act to prevent threatened damage, injury or loss. CONTRACTOR shall give CITY and DESIGN PROFESSIONAL prompt written notice if CONTRACTOR believes that any significant changes in the Work or variations from the Contract Documents have been caused thereby or are required as a result thereof. If CITY determines that a change in the Contract Documents is required because of the action taken by CONTRACTOR in response to an emergency, a Work Change Directive or Change Order will be issued.

B. A change in the Contract Documents pursuant to Paragraph 6.15 A will not be an automatic authorization of, nor a condition precedent to, entitlement to adjustment in the Contract Price or Contract Times. If CITY and CONTRACTOR are unable to agree on entitlement to, or magnitude of, an equitable adjustment in the Contract Price or Contract Times, a Claim may be made therefore as provided in Article 16. However, OWNER, DESIGN PROFESSIONAL and Consultants shall not be liable to CONTRACTOR for any costs, losses or damages (including but not limited to all fees and charges of engineers, architects, attorneys, and other professionals and all other dispute resolution costs) sustained by CONTRACTOR on or in connection with any other project or anticipated project.

6.18 Shop Drawings and Samples

A. CONTRACTOR shall submit Shop Drawings to DESIGN PROFESSIONAL for review and approval in accordance with the accepted schedule of Shop Drawings and Sample submittals (see Paragraph 2.07). All submittals shall be identified as DESIGN PROFESSIONAL may require and in the number of copies specified in the General Requirements. The data shown on the Shop Drawings shall be complete with respect to quantities, dimensions, specified performance and design criteria, materials and similar data to show DESIGN PROFESSIONAL the services, materials and equipment CONTRACTOR proposes to provide and to enable DESIGN PROFESSIONAL to review the information for the limited purposes required by Paragraph 6.18 D.

B. CONTRACTOR shall also submit Samples to DESIGN PROFESSIONAL for review and approval in accordance with said accepted schedule of Shop Drawings and Sample submittals. Each Sample shall be identified clearly as to material, Supplier, pertinent data such as catalog numbers and the use for which intended and otherwise as DESIGN PROFESSIONAL may require to enable DESIGN PROFESSIONAL to review the submittal for the limited purposes required by Paragraph 6.18 D. The numbers of each Sample to be submitted will be as specified in the Specifications.

C. Submittal Procedures:

1. Before submitting each Shop Drawing or Sample, CONTRACTOR shall have determined and verified:

a. all field measurements, quantities, dimensions, specified performance criteria, installation requirements, materials, catalog numbers and similar information with respect thereto;

b. all materials with respect to intended use, fabrication, shipping, handling, storage, assembly and installation pertaining to the performance of the Work;

c. all information relative to means, methods, techniques, sequences and procedures of construction and safety precautions and programs incident thereto; and

d. CONTRACTOR shall also have reviewed and coordinated each Shop Drawing or Sample with other Shop Drawings and Samples and with the requirements of the Work and the Contract Documents.

2. Each submittal shall bear a stamp or specific written indication that CONTRACTOR has satisfied CONTRACTOR's obligations under the Contract Documents with respect to CONTRACTOR's review and approval of that submittal.

3. At the time of each submission, CONTRACTOR shall give DESIGN PROFESSIONAL specific written notice of such variations, if any, that the Shop Drawing or Sample submitted may have from the requirements of the Contract Documents, the notice to be in a written communication separate from the submittal, and, in addition, shall cause a specific notation to be made on each Shop Drawing and Sample submitted to DESIGN PROFESSIONAL for review and approval of each such variation.

D. DESIGN PROFESSIONAL's Review:

1. DESIGN PROFESSIONAL will review and approve Shop Drawings and Samples in accordance with the schedule of Shop Drawings and Sample submittals accepted by DESIGN PROFESSIONAL as required by Paragraph 2.06. DESIGN PROFESSIONAL's review and approval will be only to determine if the items covered by the submittals will, after installation or incorporation into the Work, conform to the information given in the Contract Documents and be compatible with the design concept of the completed Project as a functioning whole as indicated by the Contract Documents.

2. DESIGN PROFESSIONAL's review and approval will not extend to means, methods, techniques, sequences or procedures of construction (except where a particular means, method, technique, sequence or procedure of construction is specifically and expressly called for by the Contract Documents) or to safety precautions or programs incident thereto. The review and approval of a separate item as such will not indicate approval of the assembly in which the item functions.

3. DESIGN PROFESSIONAL's review and approval of Shop Drawings or Samples shall not relieve CONTRACTOR from responsibility for any variation from the requirements of the Contract Documents unless CONTRACTOR has in writing called DESIGN PROFESSIONAL's attention to each such variation at the time of submission as required by Paragraph 6.18 C.3, and DESIGN PROFESSIONAL has given written approval of each such variation by specific written notation thereof incorporated into or accompanying the Shop Drawing or Sample approval; nor will any approval by DESIGN PROFESSIONAL relieve CONTRACTOR from responsibility for complying with the requirements of Paragraph 6.18 C.1.

E. Where a Shop Drawing or Sample is required by the Contract Documents or the schedule of Shop Drawings and Sample submissions accepted by DESIGN PROFESSIONAL as required by Paragraph 2.06, any related Work performed prior to DESIGN PROFESSIONAL's review and approval of the pertinent submittal will be at the sole expense and responsibility of CONTRACTOR.

F. CONTRACTOR shall make corrections required by DESIGN PROFESSIONAL and shall return the required number of corrected copies of Shop Drawings and submit as required new Samples for review and approval. CONTRACTOR shall direct specific attention in writing to revisions other than the corrections called for by DESIGN PROFESSIONAL on previous submittals.

6.19 Continuing the Work

A. CONTRACTOR shall carry on the Work and adhere to the progress schedule during all disputes or disagreements with CITY. No Work shall be delayed or postponed pending resolution of any disputes or disagreements, except as permitted by Paragraph 15.04 or as CITY and CONTRACTOR may otherwise agree in writing.

6.20 CONTRACTOR's General Warranty and Guarantee

A. CONTRACTOR warrants and guarantees to CITY, DESIGN PROFESSIONAL and Consultants that all Work will be in accordance with the Contract Documents and will not be

defective. CONTRACTOR's warranty and guarantee hereunder excludes defects or damage caused by:

1. abuse, modification or improper maintenance or operation by persons other than CONTRACTOR, Subcontractors, Suppliers or any other individual or entity for whom CONTRACTOR is responsible; or
2. normal wear and tear under normal usage.

B. CONTRACTOR's obligation to perform and complete the Work in accordance with the Contract Documents shall be absolute. None of the following will constitute an acceptance of Work that is not in accordance with the Contract Documents or a release of CONTRACTOR's obligation to perform the Work in accordance with the Contract Documents:

1. observations by DESIGN PROFESSIONAL;
2. recommendation of any progress or final payment by DESIGN PROFESSIONAL;
3. the issuance of a certificate of Substantial Completion or any payment related thereto by CITY to CONTRACTOR;
4. use or occupancy of the Work or any part thereof by OWNER;
5. any review and approval of a Shop Drawing or Sample submittal or the issuance of a notice of acceptability by DESIGN PROFESSIONAL;
6. any inspection, test or approval by others; or
7. any correction of defective Work by CITY.

C. Nonconforming Work is rejected unless expressly accepted in writing by the CITY's Representative.

ARTICLE 7 OTHER WORK

7.01 Related Work at Site

A. CITY may perform other work related to the Project at the Site by CITY's own forces, or let other direct contracts therefore, or have other work performed by utility owners. If such other work is to be performed and such fact was not noted in the Contract Documents, then:

1. Written notice thereof will be given to CONTRACTOR prior to starting any such other work, and
2. CONTRACTOR may make a Claim therefore as provided in Article 16 if CONTRACTOR believes that such performance involves additional expense to CONTRACTOR or requires additional time and the parties are unable to agree as to the amount or extent thereof.

B. CONTRACTOR shall afford each other contractor who is a party to such a direct contract, and each utility owner (and CITY, if CITY is performing the additional work with CITY's employees) proper and safe access to the Site and a reasonable opportunity for the introduction and storage of materials and equipment and the execution of such other work and shall properly connect and coordinate the Work with theirs. Unless otherwise provided in the Contract Documents, CONTRACTOR shall do all cutting, fitting and patching of the Work that may be required to properly connect or otherwise make its several parts come together and properly integrate with such other work. CONTRACTOR shall not endanger any work of others by cutting, excavating or otherwise altering their work and will only cut or alter their work with the written consent of CITY and the others whose work will be affected. The duties and responsibilities of CONTRACTOR under this Paragraph are for the benefit of such utility owners and other contractors to the extent that there are comparable provisions for the benefit of CONTRACTOR in said direct contracts between CITY and such utility owners and other contractors.

C. If the proper execution or results of any part of CONTRACTOR's Work depends upon work performed by others under this Article 7, CONTRACTOR shall inspect such other work and promptly report to CITY and DESIGN PROFESSIONAL in writing any delays, defects or deficiencies in such other work that render it unavailable or unsuitable for the proper execution or results of CONTRACTOR's Work. CONTRACTOR's failure to report same will constitute an acceptance of such other work as fit and proper for integration with CONTRACTOR's Work, except for latent or non-apparent defects and deficiencies in such other work.

7.02 Coordination

A. If CITY contracts with others for the performance of other work on the Project at the Site, the following will be set forth in Supplementary Conditions:

1. the person, firm or corporation who will have authority and responsibility for coordination of the activities among the various prime contractors will be identified;
2. the specific matters to be covered by such authority and responsibility will be itemized; and
3. the extent of such authority and responsibilities will be provided.

B. Unless otherwise provided in the Supplementary Conditions, CITY shall have sole authority and responsibility in respect of such coordination.

ARTICLE 8 CITY'S RESPONSIBILITIES

8.01 Communications to CONTRACTOR

A. Except as otherwise provided in these General Conditions, CITY shall issue all communications to CONTRACTOR.

8.02 Replacement of DESIGN PROFESSIONAL

A. In case of termination of the employment of DESIGN PROFESSIONAL, CITY shall appoint a DESIGN PROFESSIONAL whose status under the Contract Documents shall be that of the former DESIGN PROFESSIONAL.

8.03 Furnish Data and Prompt Payment

A. CITY shall promptly furnish the data required of OWNER under the Contract Documents and shall make payments to CONTRACTOR when they are due.

8.04 Lands and Easements; Reports and Tests

A. CITY's duties in respect of providing lands and easements and providing engineering surveys to establish reference points are set forth in Paragraphs 4.01 and 4.05. Paragraph 4.02 refers to CITY's duty to identify and make available to CONTRACTOR copies of reports of explorations and tests of subsurface conditions at the Site and drawings of physical conditions in existing structures at or contiguous to the Site that have been utilized by DESIGN PROFESSIONAL in preparing the Contract Documents.

8.05 Insurance

A. CITY's responsibilities, if any, for purchasing and maintaining liability and property insurance are set forth in Article 5 and the Supplementary Conditions.

8.06 Change Orders

A. CITY is obligated to execute Change Orders as indicated in Paragraph 10.03.

8.07 Inspections, Tests and Approvals

A. CITY's responsibility for certain inspections, tests and approvals is set forth in Paragraph 13.02 F.

8.08 Limitations on CITY's Responsibilities

A. The CITY shall not supervise, direct or have control or authority over, nor be responsible for, CONTRACTOR's means, methods, techniques, sequences or procedures of construction, or the safety precautions and programs incident thereto, or for any failure of CONTRACTOR to comply with Laws or Regulations applicable to the furnishing or performance of the Work. CITY will not be responsible for CONTRACTOR's failure to perform or furnish the Work in accordance with the Contract Documents.

8.09 Undisclosed Hazardous Environmental Condition

A. CITY's responsibility for an undisclosed Hazardous Environmental Condition uncovered or revealed at the Site is set forth in Paragraph 4.06.

8.10 Evidence of Financial Arrangements

A. CITY will furnish CONTRACTOR reasonable evidence that financial arrangements have been made to satisfy OWNER's obligations under the Contract.

8.11 CITY's Representative

A. CITY will provide a representative during the construction period. The duties, responsibilities and the limitations of authority of the CITY "'s Representative during construction are set forth in the Contract Documents.

8.12 Visits to Site

A. CITY's Representative will make visits to the Site at intervals appropriate to the various stages of construction as CITY's Representative deems necessary in order to observe the progress that has been made and the quality of the various aspects of CONTRACTOR's executed Work. Based on information obtained during such visits and observations, CITY's Representative will endeavor to determine, in general, if the Work is proceeding in accordance with the Contract Documents. CITY's Representative will not be required to make exhaustive or continuous on-Site inspections to check the quality or quantity of the Work.

ARTICLE 9 DESIGN PROFESSIONAL's STATUS DURING CONSTRUCTION

9.01 General Scope of DESIGN PROFESSIONAL's Duties

A. DESIGN PROFESSIONAL's efforts will be directed toward providing for CITY a greater degree of confidence that the completed Work will conform generally to the Contract Documents. On the basis of visits to the Site and on-Site observations, DESIGN PROFESSIONAL will keep CITY informed of the progress of the Work and will endeavor to guard CITY against defective Work. DESIGN PROFESSIONAL's visits to the Site and on-Site observations are subject to all the limitations on DESIGN PROFESSIONAL's authority and responsibility set forth in Paragraph 9.08.

9.02 Resident Project Representative

A. If CITY and DESIGN PROFESSIONAL agree, DESIGN PROFESSIONAL will furnish a resident Project representative to assist DESIGN PROFESSIONAL in providing more extensive observation of the Work. The responsibilities, authority and limitations thereon of any such resident Project representative and assistants will be as provided in Paragraph 9.08 and in the Supplementary Conditions.

9.03 Clarifications and Interpretations

A. DESIGN PROFESSIONAL will issue with reasonable promptness written clarifications or interpretations (which may be in the form of Drawings) of the requirements of the Drawings and Specifications prepared by the DESIGN PROFESSIONAL as DESIGN PROFESSIONAL may determine necessary, which shall be consistent with the intent of and reasonably inferable from the Contract Documents. Such written clarifications and interpretations will be binding on CITY and CONTRACTOR. If CITY or CONTRACTOR believes that a written clarification or

interpretation justifies an adjustment in the Contract Price pursuant to Article 11 and/ or the Contract Times pursuant to Article 12 and the parties are unable to agree to the amount or extent thereof, if any, a Claim may be made therefore as provided in Article 16.

9.04 Rejecting Defective Work

A. DESIGN PROFESSIONAL will have authority to disapprove or reject Work which DESIGN PROFESSIONAL believes to be defective, that DESIGN PROFESSIONAL believes will not produce a completed Project that conforms to the Contract Documents, or that will prejudice the integrity of the design concept of the completed Project as a functioning whole as indicated by the Contract Documents. DESIGN PROFESSIONAL will also have authority to require special inspection or testing of the Work as provided in Paragraph 13.04 B, whether or not the Work is fabricated, installed or completed.

9.05 Shop Drawings, Change Orders and Payments

A. In connection with DESIGN PROFESSIONAL's authority as to Shop Drawings and Samples, see Paragraph 6.18.

B. In connection with DESIGN PROFESSIONAL's authority as to Change Orders, see Article 10.

C. In connection with DESIGN PROFESSIONAL's authority as to Applications for Payment, see Article 14.

9.06 Determinations for Unit Prices

A. DESIGN PROFESSIONAL will initially determine the actual quantities and classifications of Unit Price Work performed by CONTRACTOR. DESIGN PROFESSIONAL will review with CONTRACTOR the DESIGN PROFESSIONAL's preliminary determinations on such matters before rendering a written opinion thereon (by recommendation of an Application for Payment or otherwise to the CITY). CITY reserves the right to make a final determination of the actual quantities and classifications of Unit Price Work in reviewing an Application for Payment. Within ten (10) days after the date of receipt of any such decision, CONTRACTOR may deliver to CITY and to DESIGN PROFESSIONAL written notice of intention to appeal CITY's decision pursuant to Article 16.

9.07 Decisions on Requirements of Contract Documents and Acceptability of Work

A. DESIGN PROFESSIONAL will be the initial interpreter of the requirements of the Drawings and Specifications prepared by DESIGN PROFESSIONAL and judge of the acceptability of the Work thereunder.

B. When functioning as interpreter and judge under this Paragraph 9.07, DESIGN PROFESSIONAL will not show partiality to OWNER or CONTRACTOR.

C. Claims, disputes and other matters relating to the acceptability of the Work, quantities and classifications of Unit Price Work, or the interpretation of the requirements of the Contract Documents pertaining to the performance and furnishing of the Work will be referred initially to CITY's Representative in writing with a request for a formal decision in accordance with Article 16.

9.08 Limitations on DESIGN PROFESSIONAL's Authority and Responsibilities

A. Neither DESIGN PROFESSIONAL's authority or responsibility under this Article 9 or under any other provision of the Contract Documents nor any decision made by DESIGN PROFESSIONAL in good faith either to exercise or not exercise such authority or responsibility or the undertaking, exercise or performance of any authority or responsibility by DESIGN PROFESSIONAL shall create, impose or give rise to any duty owed by DESIGN PROFESSIONAL to CONTRACTOR, any Subcontractor, any Supplier, any other person or organization, or to any surety for or employee or agent of any of them.

B. DESIGN PROFESSIONAL will not supervise, direct, control or have authority over or be responsible for CONTRACTOR's means, methods, techniques, sequences or procedures of construction, or the safety precautions and programs incident thereto, or for any failure of CONTRACTOR to comply with Laws or Regulations applicable to the furnishing or performance of the Work. DESIGN PROFESSIONAL will not be responsible for CONTRACTOR's failure to perform or furnish the Work in accordance with the Contract Documents.

C. DESIGN PROFESSIONAL will not be responsible for the acts or omissions of CONTRACTOR or of any Subcontractor, any Supplier, or of any other person or organization performing or furnishing any of the Work.

D. DESIGN PROFESSIONAL's review of the final Application for Payment and accompanying documentation, and all maintenance and operating instructions, schedules, guarantees, Bonds and certificates of inspection, tests and approvals and other documentation required to be delivered by Paragraph 14.07 will only be to determine generally that their content complies with the requirements of, and in the case of certificates of inspections, tests and approvals, that the results certified indicate compliance with, the Contract Documents.

E. The limitations upon authority and responsibility set forth in this Paragraph 9.08 shall also apply to DESIGN PROFESSIONAL's Consultants, resident Project representative and assistants as identified in the Supplementary Conditions.

ARTICLE 10 CHANGES IN THE WORK

10.01 Authorized Changes in the Work

A. Without invalidating the Contract and without notice to any surety, CITY may, at any time or from time to time, order additions, deletions or revisions in the Work. Such additions, deletions or revisions will be authorized by a Written Amendment, a Change Order, or a Work Change Directive. Upon receipt of any such document, CONTRACTOR shall promptly proceed with the Work involved that will be performed under the applicable conditions of the Contract Documents (except as otherwise specifically provided).

B. If CITY and CONTRACTOR are unable to agree on entitlement to, or on the amount or extent, if any, of an adjustment in the Contract Price pursuant to Article 11 or an adjustment of the Contract Times pursuant to Article 12 or both that should be allowed as a result of a Work Change Directive, a Claim may be made therefore as provided in Article 16.

10.02 Unauthorized Changes in the Work

A. CONTRACTOR shall not be entitled to an increase in the Contract Price or an extension of the Contract Times with respect to any work performed that is not required by the Contract Documents as amended, modified or supplemented as provided in Paragraph 3.04, except in the case of an emergency as provided in Paragraph 6.17 or in the case of uncovering Work as provided in Paragraph 13.04.

10.03 Signing of Change Orders

A. CITY and CONTRACTOR, and DESIGN PROFESSIONAL shall sign appropriate Change Orders covering:

1. changes in the Work which are:
 - a. ordered by CITY pursuant to Paragraph 10.01 A; or
 - b. required because of acceptance of defective Work under Paragraph 13.08 or correcting defective Work under Paragraph 13.09; or
 - c. agreed to by the parties;
2. changes in the Contract Price or Contract Times or both which are agreed to by the parties, including any undisputed sum or amount of time for Work actually performed in accordance with a Work Change Directive; and

3. changes in the Contract Price or Contract Times or both which embody the substance of any written decision recommended by DESIGN PROFESSIONAL and approved by CITY pursuant to Paragraph 9.06, provided that, in lieu of signing any such Change Order, an appeal may be taken from any such decision in accordance with the provisions of the Contract Documents and applicable Laws or Regulations, but during any such appeal, CONTRACTOR shall carry on the Work and adhere to the progress schedule as provided in Paragraph 6.19.

10.04 Notification to Surety

A. If notice of any change affecting the general scope of the Work or the provisions of the Contract Documents (including, but not limited to, Contract Price or Contract Times or both) is required by the provisions of any Bond to be given to a surety, the giving of any such notice will be CONTRACTOR's responsibility, and the amount of each applicable Bond will be adjusted accordingly.

ARTICLE 11 CHANGE OF CONTRACT PRICE

11.01 Change of Contract Price

A. The Contract Price constitutes the total compensation (subject to authorized adjustments) payable to CONTRACTOR for performing the Work. All duties, responsibilities and obligations assigned to or undertaken by CONTRACTOR shall be at CONTRACTOR's expense without change in the Contract Price.

B. The Contract Price may only be changed by a Change Order. Any request for an adjustment in the Contract Price shall be based on written notice delivered within fourteen (14) calendar days after occurrence of the event giving rise to the request or within fourteen (14) calendar days after first recognition of the conditions giving rise to the request. Prior notice is not required for requests or claims relating to an emergency endangering life or property as described in Paragraph 6.16. Thereafter, the CONTRACTOR shall submit written documentation of its request, including appropriate supporting documentation, within ten (10) calendar days after giving notice, unless the CITY grants an extension based on good cause shown by the CONTRACTOR that such additional time is warranted.

C. The value of any Work covered by a Change Order or of any request for an adjustment in the Contract Price will be determined as follows:

1. where the Work involved is covered by Unit Prices contained in the Contract Documents, by application of such Unit Prices to the quantities of the items involved (subject to the provisions of Paragraph 11.04); or

2. where the Work involved is not covered by Unit Prices contained in the Contract Documents, by a mutually agreed lump sum; or

3. where the Work involved is not covered by Unit Prices contained in the Contract Documents and agreement to a lump sum is not reached under Paragraph 11.01 C.2, on the basis of the Cost of the Work (determined as provided in Paragraphs 11.02 A and B) plus a CONTRACTOR's fee for overhead and profit (determined as provided in Paragraph 11.01 D).

D. The CONTRACTOR's fee allowed to CONTRACTOR for overhead and profit shall be determined as follows:

1. a mutually acceptable fixed fee; or

2. if a fixed fee is not agreed upon, then a fee based on the following percentages of the various portions of the Cost of the Work:

a. for costs incurred under Paragraphs 11.02 A.1 and 11.02 A.2, the CONTRACTOR's fee shall be ten percent (10%);

b. for costs incurred under Paragraph 11.02 A.3, the CONTRACTOR's fee shall be five percent (5%);

c. where one or more tiers of subcontracts are on the basis of the Cost of the Work plus a fee and no fixed fee is agreed upon, the intent of Paragraphs 11.01 D.2 and 11.02 A.1 through A.3 is that the Subcontractor who actually performs or furnishes the Work, at whatever tier, will be paid a fee of ten percent (10%) of the costs incurred by such Subcontractor under Paragraphs 11.02 A.1 and 11.02 A.2 and that any higher tier Subcontractor and CONTRACTOR will each be paid a fee of five percent (5%) of the amount paid to the next lower tier Subcontractor;

d. no fee shall be payable on the basis of costs itemized under Paragraphs 11.02 A.4, 11.02 A.5 and 11.02 B;

e. the amount of credit to be allowed by CONTRACTOR to CITY for any change which results in a net decrease in cost will be the amount of the actual net decrease in costs plus a deduction in CONTRACTOR's fee by an amount equal to five percent (5%) of such net decrease; and

f. when both additions and credits are involved in any one change, the adjustment in CONTRACTOR's fee shall be computed on the basis of the net change in accordance with Paragraphs 11.01 D.2.a through 11.01 D.2.e, inclusive.

E. Whenever the Cost of the Work is to be determined pursuant to Paragraphs 11.02 A and B, CONTRACTOR shall establish and maintain records thereof in accordance with generally accepted accounting practices and submit in form acceptable to CITY an itemized cost breakdown together with supporting data.

11.02 Cost of the Work

A. The term "Cost of the Work" means the sum of all costs necessarily incurred and paid by CONTRACTOR in the proper performance of the Work. When the value of any Work covered by a Change Order or when a request for an adjustment in Contract Price is determined on the basis of Cost of the Work, the costs to be reimbursed to CONTRACTOR will be only those additional or incremental costs required because of the change in the Work or because of the event giving rise to the request. Except as otherwise agreed to in writing by CITY, costs covered by Change Orders or requests shall be in amounts no higher than those prevailing in the locality of the Project, shall include only the following items and shall not include any costs itemized in 11.02 B:

1. Payroll costs for employees in the direct employ of CONTRACTOR in the performance of the Work, using occupational titles and job classifications agreed upon by CITY and CONTRACTOR. Such employees shall include, without limitation, job Site superintendents, foremen and other personnel employed full time at the Site. Payroll costs for employees not employed full time on the Work shall be apportioned on the basis of their time spent on the Work. Payroll costs shall include, but not be limited to, salaries and wages plus the cost of fringe benefits which shall include social security contributions, unemployment, excise and payroll taxes, workers' compensation, health and retirement benefits, bonuses, sick leave, vacation and holiday pay applicable thereto. The expenses of performing the Work after regular working hours, on Saturdays, Sundays or legal holidays, shall be included in the above to the extent authorized by OWNER.

2. Cost of all materials and equipment furnished and incorporated into the Work, including costs of transportation and storage thereof, and Suppliers' field services required in connection therewith. All cash discounts shall accrue to CONTRACTOR unless CITY deposits funds with CONTRACTOR with which to make payments, in which case the cash discounts shall accrue to CITY. All trade discounts, rebates and refunds and returns from sale of surplus materials and equipment shall accrue to CITY, and CONTRACTOR shall make provisions so that they may be obtained.

3. Payments made by CONTRACTOR to Subcontractors for Work performed or furnished by Subcontractors. If required by CITY, CONTRACTOR shall obtain competitive bids from Subcontractors acceptable to OWNER and CONTRACTOR and shall deliver such bids to CITY who will then determine, with the advice of DESIGN PROFESSIONAL, which bids, if any, will be accepted. If any subcontract provides that the Subcontractor is to be paid on the basis of the Cost of the Work plus a fee, the Subcontractor's Cost of the Work and fee shall be determined in the same manner as CONTRACTOR's Cost of the Work and fee as provided in Paragraphs 11.01 D and E and 11.02 A and B. All subcontracts shall be subject to the other provisions of the Contract Documents insofar as applicable.

4. Costs of special consultants (including but not limited to engineers, architects, testing laboratories, surveyors, attorneys and accountants) employed for services specifically related to the Work when such services are approved in advance by CITY in writing.

5. Other costs including the following:

a. The proportion of necessary transportation, travel and subsistence expenses of CONTRACTOR's employees incurred in discharge of duties connected with the Work.

b. Cost, including transportation and maintenance, of all materials, supplies, equipment, machinery, appliances, office and temporary facilities at the Site and hand tools not owned by the workers, which are consumed in the performance of the Work, and cost, less market value of such items used but not consumed which remain the property of CONTRACTOR.

c. Rentals of all construction equipment and machinery and the parts thereof whether rented from CONTRACTOR or others in accordance with rental agreements approved by CITY with the advice of DESIGN PROFESSIONAL, and the costs of transportation, loading, unloading, installation, assembly, dismantling and removal thereof, all in accordance with the terms of said rental agreements. The rental of any such equipment, machinery or parts shall cease when the use thereof is no longer necessary for the Work.

d. Applicable sales, consumer, use or similar taxes related to the Work, and for which CONTRACTOR is liable, imposed by Laws or Regulations.

e. Deposits lost for causes other than negligence of CONTRACTOR, any Subcontractor or anyone directly or indirectly employed by any of them or for whose acts any of them may be liable, and royalty payments and fees for permits and licenses required to perform the Work.

f. Losses and damages (and related expenses) caused by damage to the Work, not compensated by insurance or otherwise, sustained by CONTRACTOR in connection with the performance and furnishing of the Work (except losses and damages within the deductible amounts of property insurance established by CITY in accordance with Article 5), provided they have resulted from causes other than the negligence of CONTRACTOR, any Subcontractor, or anyone directly or indirectly employed by any of them or for whose acts any of them may be liable. Such losses shall include settlements made with the written consent and approval of CITY. No such losses, damages and expenses shall be included in the Cost of the Work for the purpose of determining CONTRACTOR's fee. If, however, any such loss or damage requires reconstruction and CONTRACTOR is placed in charge thereof, CONTRACTOR shall be paid for those services a fee proportionate to that stated in Paragraph 11.01 D.2.

g. The cost of utilities, fuel and sanitary facilities at the Site.

h. Minor expenses such as telegrams, long distance telephone calls, telephone service at the Site, expressage and similar petty cash items in connection with the Work.

i. Cost of premiums for additional or increased Bonds, or for insurance required because of approved changes in the Work.

B. Costs excluded: The term “Cost of the Work” shall not include any of the following:

1. Payroll costs and other compensation of CONTRACTOR's officers, executives, principals (of partnership and sole proprietorships), general managers, engineers, architects, estimators, attorneys, auditors, accountants, purchasing and contracting agents, expeditors, timekeepers, clerks and other personnel employed by CONTRACTOR whether at the Site or in CONTRACTOR's principal or a branch office for general administration of the Work (if not specifically included in the agreed upon occupational titles and job classifications referred to in Paragraph 11.02 A.1 or specifically covered by Paragraph 11.02 A.4), all of which are to be considered administrative costs covered by the CONTRACTOR's fee.

2. Expenses of CONTRACTOR's principal and branch offices other than CONTRACTOR's office at the Site.

3. Any part of CONTRACTOR's capital expenses, including interest on CONTRACTOR's capital employed for the Work and charges against CONTRACTOR for delinquent payments.

4. Costs due to the negligence of CONTRACTOR, any Subcontractor, or anyone directly or indirectly employed by any of them or for whose acts any of them may be liable, including but not limited to, the correction of defective Work, disposal of materials, or equipment wrongly supplied, and making good any damage to property.

5. Other overhead or general expense costs of any kind and the costs of any item not specifically and expressly included in Paragraph 11.02 A.

11.03 Cash Allowances

A. It is understood that CONTRACTOR has included in the Contract Price all allowances so named in the Contract Documents and shall cause the Work so covered to be furnished and performed for such sums as may be acceptable to CITY. CONTRACTOR agrees that:

1. the allowances include the cost to CONTRACTOR (less any applicable trade discounts) of materials and equipment required by the allowances to be delivered at the Site, and all applicable taxes; and

2. CONTRACTOR's costs for unloading and handling on the Site, labor, installation costs, overhead, profit and other expenses contemplated for the allowances have been included in the Contract Price and not in the allowances, and no demand for additional payment on account of any of the foregoing will be valid.

B. Prior to final payment, an appropriate Change Order will be issued by CITY to reflect actual amounts due CONTRACTOR on account of Work covered by allowances, and the Contract Price shall be correspondingly adjusted.

11.04 Unit Price Work

A. Where the Contract Documents provide that all or part of the Work is to be Unit Price Work, initially the Contract Price will be deemed to include for all Unit Price Work an amount equal to the sum of the established unit price for each separately identified item of Unit Price Work times the estimated quantity of each item as indicated in the Contract. The estimated quantities of items of Unit Price Work are not guaranteed and are solely for the purpose of comparison of Bids and determining an initial Contract Price. Determinations of the actual quantities and classifications of Unit Price Work performed by CONTRACTOR will be made in accordance with Paragraph 9.06.

B. Each unit price will be deemed to include an amount considered by CONTRACTOR to be adequate to cover CONTRACTOR's overhead and profit for each separately identified item.

C. CITY or CONTRACTOR may negotiate an adjustment of the price per unit of Unit Price Work stated in the Contract if:

1. the quantity of any item of Unit Price Work performed by CONTRACTOR differs by twenty percent (20%) or more from the estimated quantity of such item indicated in the Contract; and

2. there is no corresponding adjustment with respect to any other item of Work; and

3. CONTRACTOR believes that CONTRACTOR is entitled to an increase in Contract Price as a result of having incurred additional expense or CITY believes that CITY is entitled to a decrease in Contract Price.

11.05 Dispute Resolution

A. If CITY and CONTRACTOR are unable to agree on entitlement to, or magnitude of, an equitable adjustment in the Contract Price in accordance with Article 11 within fourteen (14) calendar days from the receipt of supporting documentation of the request pursuant to 11.01.B., unless the CITY grants an extension based on good cause shown by the CONTRACTOR that such additional time is warranted, then a Claim for such adjustment may be made pursuant to Article 16.

ARTICLE 12 CONTRACT TIMES

12.01 Time of the Essence

A. All times stated in the Contract Documents are of the essence of the Contract.

12.02 Change of Contract Times

A. The Contract Times (or Milestones) may only be changed by a Change Order. Any request for an adjustment in the Contract Times shall be based on written notice delivered within fourteen (14) calendar days after occurrence of the event giving rise to the request or within fourteen (14) calendar days after first recognition of the conditions giving rise to the request. Thereafter, the CONTRACTOR shall submit written documentation of its requests, including appropriate supporting documentation, within ten (10) days after giving notice, unless the CITY grants an extension based on good cause shown by the CONTRACTOR that such additional time is warranted.

12.03 Proof Required To Justify an Extension of Time For Excusable and Compensable Delays

A. In support of any request for an extension of the Contract Times pursuant to this Article, CONTRACTOR must demonstrate to the reasonable satisfaction of the CITY that the critical path of the approved baseline project schedule was delayed. CONTRACTOR shall be entitled to an increase in contract time for the number of days that the critical path was delayed solely as a result of the compensable or excusable event. A compensable or excusable event includes, but is not limited to:

1. unreasonable delay of issuance of Notice to Proceed by CITY;
2. CITY's unreasonable delay of delivery furnished materials, equipment, or work;
3. unreasonable delay responding to shop drawings and submittals;
4. CITY's unreasonable delay in issuing a Change Order;
5. an order by the CITY to stop the Work where the CONTRACTOR was not at fault; and
6. other reasonable grounds as determined by the City in its sole discretion.

B. CONTRACTOR shall compare the critical path of the approved baseline project schedule to the actual critical path of the Work, identifying the specific impact of the compensable or excusable event.

C. CONTRACTOR shall submit to the CITY a written time impact analysis illustrating the influence of each compensable or excusable event on the date of Substantial Completion. The

time impact analysis shall demonstrate the time impact based on the date of the delay in time and the event time computations or all affected activities.

D. If the critical path of the Work is delayed by "Force Majeure", the CONTRACTOR shall be entitled only to an extension of the Contract Times for the number of days of delay to the critical path. For purposes of this paragraph, "Force Majeure" shall mean fire, tornado, flood, earthquake, war, act of terrorism, civil disturbance, or labor strikes away from the project site.

E. Extensions of contract time pursuant to the this section will be granted only to the extent that the time adjustments exceed the total float time available when the event causing the delay occurred.

12.04 Delays Within CONTRACTOR's Control

A. The Contract Times (or Milestones) will not be extended due to delays within the control of CONTRACTOR. Delays attributable to and within the control of a Subcontractor or Supplier shall be deemed to be delays within the control of CONTRACTOR.

12.05 Delays Beyond the CITY's and CONTRACTOR's Control

A. Where CONTRACTOR is prevented from completing any part of the Work within the Contract Times (or Milestones) due to delay beyond the control of both CITY and CONTRACTOR, an extension of the Contract Times (or Milestones) in an amount equal to the time lost due to such delay shall be CONTRACTOR's sole and exclusive remedy for such delay.

12.06 Delay Damages

A. In no event shall CITY be liable to CONTRACTOR, any Subcontractor, any Supplier, any other person or organization, or to any surety for or employee or agent of any of them, for damages arising out of or resulting from:

1. delays caused by or within the control of CONTRACTOR, or
2. delays beyond the control of CITY or CONTRACTOR including but not limited to fires, floods, epidemics, abnormal weather conditions, acts of God or acts or neglect by utility owners or other contractors performing other work as contemplated by Article 7.

B. Nothing in this Paragraph 12.06 bars a change in Contract Price pursuant to this Article 12 to compensate CONTRACTOR due to delay, interference, or disruption directly attributable to actions or inaction of CITY, DESIGN PROFESSIONAL, Consultant or anyone for whom CITY, DESIGN PROFESSIONAL or Consultant is responsible.

12.07 Dispute Resolution

A. If CITY and CONTRACTOR are unable to agree on entitlement to, or magnitude of, an equitable adjustment in the Contract Time in accordance with Article 12 within fourteen (14) calendar days from the receipt of supporting documentation of the request pursuant to 12.02, unless the CITY grants an extension based on good cause shown by the CONTRACTOR that such additional time is warranted, then a Claim for such adjustment may be made pursuant to Article 16.

ARTICLE 13 TESTS AND INSPECTIONS; CORRECTION, REMOVAL OR ACCEPTANCE OF DEFECTIVE WORK

13.01 Access to Work

A. CITY, DESIGN PROFESSIONAL, Consultants, other representatives and personnel of CITY, independent testing laboratories and governmental agencies with jurisdictional interests will have access to the Site and Work at reasonable times for their observation, inspecting and testing. CONTRACTOR shall provide them proper and safe conditions for such access and advise them of CONTRACTOR's Site safety procedures and programs so that they may comply therewith as applicable.

13.02 Tests and Inspections

A. CONTRACTOR shall give DESIGN PROFESSIONAL and CITY's Representative timely notice of readiness of the Work for all required inspections, tests or approvals, and shall cooperate with inspection and testing personnel to facilitate required inspections or tests.

B. If any Work (or the work of others at the Site) that is to be inspected, tested or approved is covered by CONTRACTOR without written approval required by Paragraphs 13.02 D or 13.02 E, it must, if requested by CITY's Representative, be uncovered for observation.

C. Uncovering Work as provided in Paragraph 13.02 B, shall be at CONTRACTOR's expense unless CONTRACTOR has given DESIGN PROFESSIONAL and CITY's Representative timely notice of CONTRACTOR's intention to cover the same and DESIGN PROFESSIONAL and CITY's Representative have not acted with reasonable promptness in response to such notice.

D. If Laws or Regulations of any public body (including City) having jurisdiction require any Work (or part thereof) specifically to be inspected, tested or approved by an employee or other representative of such public body, CONTRACTOR shall assume full responsibility for arranging and obtaining such inspections, tests or approvals, pay all costs in connection therewith, and furnish DESIGN PROFESSIONAL and CITY's Representative the required certificates of inspection or approval.

E. CONTRACTOR shall be responsible for arranging and obtaining and shall pay all costs in connection with any inspections, tests or approvals required for CITY's and DESIGN PROFESSIONAL's acceptance of materials or equipment to be incorporated into the Work, or acceptance of materials, mix designs, or equipment submitted for approval prior to CONTRACTOR's purchase thereof for incorporation into the Work. Such inspections, tests, or approvals shall be performed by organizations acceptable to CITY and DESIGN PROFESSIONAL.

F. CITY shall employ and pay for the services of an independent testing laboratory to perform all inspections, tests, or approvals required by the Contract Documents except:

1. for inspections, tests or approvals covered by Paragraph 13.02 D and E;
2. that costs incurred in connection with tests or inspections conducted pursuant to Paragraph 13.04 B shall be paid as provided in said Paragraph 13.04 B; and
3. as otherwise specifically provided in the Contract Documents.

13.03 Notice of Defects

A. Prompt notice of all defective Work of which either CITY or DESIGN PROFESSIONAL has actual knowledge will be given to CONTRACTOR. Defective Work may be rejected, corrected or accepted as provided in this Article 13.

13.04 Uncovering Work

A. If any Work (or the work of others at the Site) is covered contrary to the written request of DESIGN PROFESSIONAL or CITY's Representative, it must, if requested by CITY's Representative, be uncovered for DESIGN PROFESSIONAL's or CITY's Representative's observation and replaced at CONTRACTOR's expense.

B. If CITY considers it necessary or advisable that covered Work be observed by DESIGN PROFESSIONAL or CITY's Representative or be inspected or tested by others, CONTRACTOR, at CITY's request, shall uncover, expose or otherwise make available for observation, inspection or testing as may be required, that portion of the Work in question, furnishing all necessary labor, material and equipment. If it is found that such Work is defective, CONTRACTOR shall pay all costs, losses and damages (including but not limited to all fees and charges of engineers, architects, attorneys, and other professionals and all court or arbitration or other dispute resolution costs) caused by, arising out of or resulting from such uncovering, exposure, observation, inspection and testing and of satisfactory replacement or reconstruction

(including but not limited to all costs of repair or replacement of work of others); and CITY shall be entitled to an appropriate decrease in the Contract Price. If the parties are unable to agree as to the amount thereof, CITY may make a Claim therefore as provided in Article 16. If, however, such Work is not found to be defective, CONTRACTOR shall be allowed an increase in the Contract Price or an extension of the Contract Times (or Milestones), or both, directly attributable to such uncovering, exposure, observation, inspection, testing, replacement and reconstruction. If the parties are unable to agree as to the amount or extent thereof, CONTRACTOR may make a Claim therefore as provided in Article 16.

13.05 CITY May Stop the Work

A. If the Work is defective, or CONTRACTOR fails to supply sufficient skilled workers or suitable materials or equipment, or fails to furnish or perform the Work in such a way that the completed Work will conform to the Contract Documents, CITY may order CONTRACTOR to stop the Work, or any portion thereof, until the cause for such order has been eliminated; however, this right of CITY to stop the Work shall not give rise to any duty on the part of CITY to exercise this right for the benefit of CONTRACTOR, any Subcontractor, Supplier, other individual or entity or any surety or employee or agent of any of them.

13.06 Correction or Removal of Defective Work

A. If required by CITY, CONTRACTOR shall promptly, as directed, either correct all defective Work, whether or not fabricated, installed or completed, or, if the Work has been rejected by either DESIGN PROFESSIONAL or CITY's Representative, remove it and replace it with Work that is not defective. CONTRACTOR shall pay all costs, losses and damages (including but not limited to all fees and charges of engineers, architects, attorneys, and other professionals and all court or arbitration or other dispute resolution costs) caused by or resulting from such correction or removal (including but not limited to all costs of repair or replacement of work of others).

13.07 Correction Period

A. If within one (1) year after the date of Substantial Completion, or such longer period of time as may be prescribed by Laws or Regulations, by the terms of any applicable special guarantee required by the Contract Documents, or by any specific provision of the Contract Documents, any Work is found to be defective, or if the repair of any damages to the land or areas made available for CONTRACTOR's use by CITY or permitted by Laws and Regulations as contemplated in Paragraph 6.10 is found to be defective, CONTRACTOR shall promptly, without cost to CITY and in accordance with CITY's written instructions:

1. correct the repair of damages to such land or areas; or
2. correct such defective Work, or if it has been rejected by CITY, remove it from the Site and replace it with Work that is not defective; and
3. satisfactorily correct or remove and replace any damage to other Work or to the work of others or damage to other lands or areas resulting therefrom. If CONTRACTOR does not promptly comply with the terms of such instructions, or in the event of an emergency where delay by CONTRACTOR would cause serious risk of loss or damage, CITY may have the defective Work corrected or the rejected Work removed and replaced, and all costs, losses and damages (including but not limited to all fees and charges of engineers, architects, attorneys, and other professionals and all court or arbitration or other dispute resolution costs) caused by or resulting from such removal and replacement (including but not limited to all costs of repair or replacement of work of others) will be paid by CONTRACTOR.

B. In special circumstances where a particular item of equipment is placed in continuous service before Substantial Completion of all the Work, the correction period for that item may start to run from an earlier date if so provided in the Specifications or by Written Amendment.

C. Where defective Work (and damage to other Work resulting therefrom) has been corrected or removed and replaced under this Paragraph 13.07, the correction period hereunder

with respect to such Work will be extended for an additional period of one (1) year, or such longer period of time as may be prescribed within Paragraph 13.07 A, after such correction or removal and replacement has been satisfactorily completed.

D. CONTRACTOR's obligations under this Paragraph 13.07 are in addition to any other obligation or warranty. The provisions of this Paragraph 13.07 shall not be construed as a substitute for or waiver of the provisions of any applicable statute of limitation or repose.

13.08 Acceptance of Defective Work

A. If, instead of requiring correction or removal and replacement of defective Work, CITY prefers to accept it, CITY may do so. CONTRACTOR shall pay all costs, losses and damages (including but not limited to all fees and charges of engineers, architects, attorneys, and other professionals and all court or arbitration or other dispute resolution costs) attributable to CITY's evaluation of and determination to accept such defective Work and shall pay OWNER for the diminished value of the Work. If any such acceptance occurs prior to DESIGN PROFESSIONAL's recommendation of final payment, a Change Order will be issued incorporating the necessary revisions into the Contract Documents with respect to the Work and, due to the diminished value of the Work, CITY shall be entitled to an appropriate decrease in the Contract Price. If the parties are unable to agree as to the amount thereof, CITY may make a Claim therefore as provided in Article 16. If the acceptance of defective Work occurs after such recommendation, an appropriate amount shall be paid by CONTRACTOR to CITY.

13.09 CITY May Correct Defective Work

A. If CONTRACTOR fails within a reasonable time after written notice from DESIGN PROFESSIONAL or CITY's Representative to correct defective Work or to remove and replace rejected Work as required by CITY in accordance with Paragraph 13.06, or if CONTRACTOR fails to perform the Work in accordance with the Contract Documents, or if CONTRACTOR fails to comply with any other provision of the Contract Documents, CITY may, after seven (7) days written notice to CONTRACTOR, correct and remedy any such deficiency.

B. CITY shall proceed expeditiously when exercising the rights and remedies under this Paragraph 13.09. In connection with such corrective and remedial action, CITY may exclude CONTRACTOR from all or part of the Site; take possession of all or part of the Work and suspend CONTRACTOR's services related thereto; take possession of CONTRACTOR's tools, appliances, construction equipment and machinery at the Site; and incorporate into the Work all materials and equipment stored at the Site or for which CITY has paid CONTRACTOR but which are stored elsewhere. CONTRACTOR shall allow CITY, CITY's Representative, agents and employees, CITY's other contractors, DESIGN PROFESSIONAL and Consultants access to the Site to enable CITY to exercise the rights and remedies under this Paragraph 13.09.

C. All costs, losses and damages (including but not limited to all fees and charges of engineers, architects, attorneys, and other professionals and all court or arbitration or other dispute resolution costs) incurred or sustained by CITY in exercising such rights and remedies will be charged against CONTRACTOR and a Change Order will be issued incorporating the necessary revisions into the Contract Documents with respect to the Work; and CITY shall be entitled to an appropriate decrease in the Contract Price. If CITY and CONTRACTOR are unable to agree as to the amount thereof, CITY may make a Claim therefore as provided in Article 16. Such Claims for costs, losses and damages will include but not be limited to all costs of repair or replacement of work of others destroyed or damaged by correction, removal and replacement of CONTRACTOR's defective or rejected Work.

D. CONTRACTOR shall not be allowed an extension of the Contract Times (or Milestones) because of any delay in the performance of the Work attributable to the exercise by CITY of CITY's rights and remedies under Paragraphs 13.06 and 13.09.

ARTICLE 14 PAYMENTS TO CONTRACTOR AND COMPLETION

14.01 Schedule of Values

A. 01290.02 Schedule of Values established as provided in Article 2 will serve as the basis for progress payments and will be incorporated into form 01290.01 Application for Payment acceptable to DESIGN PROFESSIONAL and CITY. Progress payments for Unit Price Work will be based on the number of units completed.

14.02 Application for Progress Payments

A. Application for Payment

1. At least twenty (20) days before the date stipulated in the Supplementary Conditions for each progress payment (but not more often than once a month), CONTRACTOR shall submit to DESIGN PROFESSIONAL for review an Application for Payment filled out and signed by CONTRACTOR covering the Work completed as of the date of the Application and accompanied by such supporting documentation as is required by the Contract Documents. If payment is requested on the basis of materials and equipment not incorporated into the Work but delivered and suitably stored at the Site or at another location agreed to in writing, the Application for Payment shall also be accompanied by a bill of sale, paid invoice or other documentation warranting that CITY has received the materials and equipment free and clear of all Liens and evidence that the materials and equipment are covered by appropriate property insurance and other arrangements to protect CITY's interest therein, all of which will be subject to CITY's approval.

2. Beginning with the second Application for Payment, each Application shall include:

a. an affidavit of CONTRACTOR stating that all previous progress payments received for the Work have been applied to discharge CONTRACTOR's legitimate obligations associated with prior Applications for Payment, and

b. a copy of the most recent 00485.01 M/WBE Monthly Utilization Report CONTRACTOR has submitted to the CITY's Civil Rights and Equal Opportunity Department.

c. a copy of the most recent 00485.02 Project Workforce Monthly Report and 00485.03 Company-Wide Workforce Monthly Report CONTRACTOR has submitted to the OWNER's Civil Rights and Equal Opportunity Department.

d. an update to the approved schedule pursuant to paragraphs 6.04 and 6.05.

3. The amount of retainage with respect to progress payments will be stated in the Supplementary Conditions.

B. Review of Applications

1. DESIGN PROFESSIONAL will, within ten (10) days after receipt of each Application for Payment, either indicate in writing a recommendation of payment and present the Application to CITY, or return the Application to CONTRACTOR indicating in writing DESIGN PROFESSIONAL's reasons for refusing to recommend payment. In the latter case, CONTRACTOR shall make the necessary corrections and resubmit the Application.

a. After presentation of the Application for Payment to CITY, and if CITY's Representative agrees with DESIGN PROFESSIONAL's recommendation, the amount recommended will (subject to the provisions of Paragraph 14.02 B.4) become due and will be paid by CITY to CONTRACTOR, subject to the provisions of Laws or Regulations.

b. No payment shall be approved until the CONTRACTOR has submitted with the Application accompanying documentation as required by the Contract Documents, including, but not limited to, the documentation required by paragraphs 6.04 and 6.05.

2. DESIGN PROFESSIONAL's recommendation of any payment requested in an Application for Payment will constitute a representation by DESIGN PROFESSIONAL to CITY, based on DESIGN PROFESSIONAL's observations of the executed Work as an experienced and qualified DESIGN PROFESSIONAL and on DESIGN PROFESSIONAL's

review of the Application for Payment and the accompanying data and schedules, that to the best of DESIGN PROFESSIONAL's knowledge, information and belief:

- a. the Work has progressed to the point indicated;
- b. the quality of the Work is generally in accordance with the Contract Documents (subject to an evaluation of the Work as a functioning whole prior to or upon Substantial Completion, to the results of any subsequent tests called for in the Contract Documents, to a final determination of quantities and classifications for Unit Price Work under Paragraph 9.06, and to any other qualifications stated in the recommendation); and
- c. the conditions precedent to CONTRACTOR being entitled to such payment appear to have been fulfilled in so far as it is DESIGN PROFESSIONAL's responsibility to observe the Work.

3. DESIGN PROFESSIONAL's recommendation of any payment, including final payment, shall not mean that DESIGN PROFESSIONAL is responsible for CONTRACTOR's means, methods, techniques, sequence or procedures of construction, safety precautions and programs incident thereto, or any failure of CONTRACTOR to comply with Laws or Regulations applicable to the furnishing or performance of Work.

4. DESIGN PROFESSIONAL may refuse to recommend the whole or any part of any payment if, in DESIGN PROFESSIONAL's opinion, it would be incorrect to make the representations to CITY referred to in Paragraph 14.02 B.2. DESIGN PROFESSIONAL may also refuse to recommend any such payment or, because of subsequently discovered evidence or the results of subsequent inspections or tests, nullify any such payment previously recommended, to such extent as may be necessary in DESIGN PROFESSIONAL's opinion to protect CITY from loss because:

- a. the Work is defective, or completed Work has been damaged requiring correction or replacement;
- b. the Contract Price has been reduced by Written Amendment or Change Orders;
- c. CITY has been required to correct defective Work or complete Work in accordance with Paragraph 13.09; or
- d. DESIGN PROFESSIONAL has actual knowledge of the occurrence of any of the events enumerated in Paragraph 15.02.

C. Reduction in Payment

1. CITY may refuse to make payment of the full amount recommended by DESIGN PROFESSIONAL because:

- a. Claims have been made by third parties against CITY on account of CONTRACTOR's performance or furnishing of the Work; or
- b. Claims have been made by CITY against CONTRACTOR in connection with the Work, except where CONTRACTOR has delivered a specific Bond satisfactory to CITY to secure the satisfaction and discharge of such Claims;
- c. there are other items entitling CITY to a set-off against the amount recommended; or
- d. CITY has actual knowledge of the occurrence of any of the events enumerated in Paragraphs 14.02 B.4.a through c or 15.02 A.1 through 4; but CITY must give CONTRACTOR written notice (with a copy to DESIGN PROFESSIONAL) stating the reasons for such action and promptly pay CONTRACTOR the amount so withheld, or any adjustment thereto agreed to by CITY and CONTRACTOR, when CONTRACTOR corrects to CITY's satisfaction the reasons for such action; or
- e. CITY has made a different determination of the actual quantities and classifications of Unit Price Work.

14.03 CONTRACTOR's Warranty of Title

A. CONTRACTOR warrants and guarantees that title to all Work, materials and equipment covered by any Application for Payment, whether incorporated into the Project or not, will pass to CITY no later than the time of payment, free and clear of all Liens.

14.04 Substantial Completion

A. When CONTRACTOR considers the entire Work ready for its intended use CONTRACTOR shall notify CITY and DESIGN PROFESSIONAL in writing that the entire Work is substantially complete (except for items specifically listed by CONTRACTOR as incomplete) and request that CITY issue a certificate of Substantial Completion. Within a reasonable time thereafter, CITY, together with CONTRACTOR and DESIGN PROFESSIONAL, shall make an inspection of the Work to determine the status of completion. If DESIGN PROFESSIONAL does not consider the Work substantially complete, DESIGN PROFESSIONAL will notify CONTRACTOR and CITY in writing giving the reasons therefore. If DESIGN PROFESSIONAL considers the Work substantially complete, DESIGN PROFESSIONAL will prepare and deliver to CITY a recommended certificate of Substantial Completion that shall establish the date of Substantial Completion. There shall be attached to the certificate a tentative list of items to be completed or corrected before final payment. CITY shall have seven (7) days after receipt of the recommended certificate during which to make written objection to DESIGN PROFESSIONAL as to any provisions of the certificate or attached list. At the time of delivery of the recommended certificate of Substantial Completion, DESIGN PROFESSIONAL will deliver to CITY and CONTRACTOR a written recommendation as to division of responsibilities pending final payment between CITY and CONTRACTOR with respect to security, operation, safety, protection of the Work, maintenance, heat, utilities, insurance and warranties and guarantees.

B. CITY shall have the right to exclude CONTRACTOR from the Site after the date of Substantial Completion, but CITY shall allow CONTRACTOR reasonable access to complete or correct items on the tentative list.

14.05 Partial Utilization

A. Use by CITY at CITY's option of any substantially completed part of the Work which has specifically been identified in the Contract Documents, or which CITY, DESIGN PROFESSIONAL and CONTRACTOR agree constitutes a separately functioning and usable part of the Work that can be used by CITY for its intended purpose without significant interference with CONTRACTOR's performance of the remainder of the Work, may be accomplished prior to Substantial Completion of all the Work subject to the following:

1. CITY at any time may request CONTRACTOR in writing to permit CITY to use any such part of the Work which CITY believes to be ready for its intended use and substantially complete. If CONTRACTOR agrees that such part of the Work is substantially complete, CONTRACTOR will certify to CITY and DESIGN PROFESSIONAL that such part of the Work is substantially complete and request CITY to issue a certificate of Substantial Completion for that part of the Work. CONTRACTOR at any time may notify CITY and DESIGN PROFESSIONAL in writing that CONTRACTOR considers any such part of the Work ready for its intended use and substantially complete and request CITY to issue a certificate of Substantial Completion for that part of the Work. Within a reasonable time after either such request, CITY, together with CONTRACTOR and DESIGN PROFESSIONAL, shall make an inspection of that part of the Work to determine its status of completion. If DESIGN PROFESSIONAL does not consider that part of the Work to be substantially complete, DESIGN PROFESSIONAL will notify CITY and CONTRACTOR in writing, giving the reasons therefore. If DESIGN PROFESSIONAL considers that part of the Work to be substantially complete, the provisions of Paragraph 14.04 will apply with respect to certification of Substantial Completion of that part of the Work and the division of responsibility in respect thereof and access thereto.

2. No occupancy or separate operation of part of the Work will be accomplished prior to compliance with the requirements of Paragraph 5.09 with respect to property insurance.

14.06 Final Inspection

A. Upon written notice from CONTRACTOR that the entire Work or an agreed portion thereof is complete, DESIGN PROFESSIONAL will make a final inspection with CITY and CONTRACTOR and will notify CONTRACTOR in writing of all particulars in which this inspection reveals that the Work is incomplete or defective. CONTRACTOR shall immediately take such measures as are necessary to complete such Work or remedy such deficiencies.

14.07 Final Payment

A. Application for Payment

1. After CONTRACTOR has completed all corrections required by Paragraph 14.06 to the satisfaction of DESIGN PROFESSIONAL and CITY's Representative and delivered in accordance with the Contract Documents all maintenance and operating instructions, schedules, guarantees, Bonds, certificates or other evidence of insurance required by Paragraph 5.04, certificates of inspection, marked-up record documents (as provided in Paragraph 6.13) and other documents, CONTRACTOR may make application for final payment following the procedure for progress payments.

2. The final Application for Payment shall be accompanied (except as previously delivered) by:

a. all documentation required by the Contract Documents, including but not limited to the evidence of insurance required by Subparagraph 5.04 B.7; and

b. 01290.14 "Contractor Affidavit for Final Payment" from CONTRACTOR and 01290.15 "Subcontractor Affidavit for Final Payment" from all Subcontractors, regardless of tier.

B. Review of Application and Acceptance

1. If, on the basis of DESIGN PROFESSIONAL's and CITY's Representative's observation of the Work during construction and final inspection, and DESIGN PROFESSIONAL's and CITY's Representative's review of the final Application for Payment and accompanying documentation as required by the Contract Documents, DESIGN PROFESSIONAL and CITY's Representative are satisfied that the Work has been completed and CONTRACTOR's other obligations under the Contract Documents have been fulfilled, DESIGN PROFESSIONAL will, within ten (10) days after receipt of the final Application for Payment, indicate in writing DESIGN PROFESSIONAL's and CITY's Representative's recommendation of payment and present the Application to CITY for payment. At the same time DESIGN PROFESSIONAL will also give written notice to CITY and CONTRACTOR that the Work is acceptable subject to the provisions of Paragraph 14.09.

2. Otherwise, DESIGN PROFESSIONAL will return the Application to CONTRACTOR, indicating in writing the reasons for refusing to recommend final payment, in which case CONTRACTOR shall make the necessary corrections and resubmit the Application to DESIGN PROFESSIONAL. After the presentation to CITY of the Application and accompanying documentation, in appropriate form and substance, including applicable federal and state prevailing wage provisions, and with DESIGN PROFESSIONAL's recommendation and notice of acceptability, the amount recommended by DESIGN PROFESSIONAL will become due and will be paid by CITY to CONTRACTOR in accordance with Laws and Regulations.

14.08 Final Completion Delayed

A. If, through no fault of CONTRACTOR, final completion of the Work is significantly delayed and if DESIGN PROFESSIONAL so recommends and CITY concurs, CITY shall, upon

receipt of CONTRACTOR's final Application for Payment and recommendation of DESIGN PROFESSIONAL, and without terminating the Contract, make payment of the balance due for that portion of the Work fully completed and accepted. If the remaining balance to be held by CITY for Work not fully completed or corrected is less than the retainage stipulated in the Supplementary Conditions, and if Bonds have been furnished as required in Paragraph 5.01, the written consent of the surety to the payment of the balance due for that portion of the Work fully completed and accepted shall be submitted by CONTRACTOR to DESIGN PROFESSIONAL with the Application for Payment. Payment shall be made under the terms and conditions governing final payment, except that it shall not constitute a waiver of Claims.

14.09 Waiver of Claims

A. The making and acceptance of final payment will constitute:

1. a waiver of all claims by CITY against CONTRACTOR, except claims previously made in writing and still unsettled, or claims arising from defective Work appearing after final inspection pursuant to Paragraph 14.06, from failure to comply with the Contract Documents or the terms of any special guarantees specified therein, or from CONTRACTOR's continuing obligations under the Contract Documents; and

2. a waiver of all Claims by CONTRACTOR against CITY other than those previously made in writing pursuant to Paragraphs 16.02 and 16.03 and still unsettled.

14.10 Completion of Work by CITY

A. If CITY must complete the Work, all costs and charges incurred by CITY, together with the cost of completing the Work under the Contract, will be deducted from any monies due or which may become due CONTRACTOR. If such expense exceeds the sum which would have been payable under the Contract, then CONTRACTOR and the surety shall be liable and shall pay to CITY the amount of such excess.

ARTICLE 15 SUSPENSION OF WORK AND TERMINATION

15.01 CITY May Suspend Work

A. Notwithstanding any other provision of this Contract, at any time and without cause, and at its sole and absolute discretion, CITY, may suspend the Work or any portion of the Work by written notice to CONTRACTOR, which will initially fix the date on which Work will be resumed. CONTRACTOR shall resume the Work on the date so fixed in the notice unless the date is changed by a subsequent written notice from CITY. CONTRACTOR may be allowed an adjustment in the Contract Price or an extension of the Contract Times, or both, directly attributable to any suspension if CONTRACTOR makes a Claim therefore in accordance with Article 16.

B. CONTRACTOR will not be allowed an adjustment in the Contract Price or an extension of the Contract Times if CITY suspends the Work because CONTRACTOR's acts or omissions create or cause an emergency that CITY believes affects the safety or protection of persons, the Work, or property at the Site or adjacent thereto. CITY may order CONTRACTOR to stop the Work, or any portion thereof, until the cause for such order has been adequately addressed by CONTRACTOR; however, this right of CITY to stop the Work shall not give rise to any duty on the part of CITY to exercise this right for the benefit of CONTRACTOR, any Subcontractor, Supplier, other individual or entity or any surety or employee or agent of any of them.

15.02 CITY May Terminate for Default

A. CONTRACTOR may be deemed in default and CITY may terminate the services of CONTRACTOR upon the occurrence of any one or more of the following events:

1. CONTRACTOR fails to perform the Work in accordance with the Contract Documents (including, but not limited to, failure to supply sufficient skilled workers or suitable materials or equipment or failure to adhere to the progress schedule established under Paragraph 2.06 and 2.07 as adjusted from time to time pursuant to Paragraphs 6.04, 6.05, 12.02 and 12.03);

2. CONTRACTOR abandons the Work or declares its intention to abandon the Work;
3. CONTRACTOR assigns or attempts to assign its rights or obligations under this Contract or any part thereof to any third party without the prior written consent of CITY;
4. CONTRACTOR fails to make prompt payment duly owing to any subcontractor for Work completed in accordance to the Contract Documents or material supplier for materials delivered for incorporation into the Work within thirty (30) calendar days after payment was due;
5. CONTRACTOR fails to achieve the required dates of substantial and final completion;
6. CONTRACTOR disregards Laws or Regulations of any public body having jurisdiction;
7. CONTRACTOR disregards the authority of DESIGN PROFESSIONAL or OWNER;
or
8. CONTRACTOR otherwise violates in any substantial way any provisions of the Contract Documents.

B. CITY may, after giving CONTRACTOR (and the surety) seven (7) days written notice and to the extent permitted by Laws or Regulations, terminate the services of CONTRACTOR, exclude CONTRACTOR from the Site and take possession of the Work and of all CONTRACTOR's tools, appliances, construction equipment and machinery at the Site and use the same to the full extent they could be used by CONTRACTOR (without liability to CONTRACTOR for trespass or conversion), incorporate into the Work all materials and equipment stored at the Site or for which CITY has paid CONTRACTOR but which are stored elsewhere, and finish the Work as CITY may deem expedient. In such case, CONTRACTOR shall not be entitled to receive any further payment until the Work is finished. If the unpaid balance of the Contract Price exceeds all costs, losses and damages (including but not limited to all fees and charges of engineers, architects, attorneys, and other professionals and all court or arbitration or other dispute resolution costs) sustained by CITY arising out of or resulting from completing the Work, such excess may be paid to CONTRACTOR. If such costs, losses and damages exceed such unpaid balance, CONTRACTOR shall pay the difference to CITY within fourteen (14) calendar days of CITY'S demand for payment. When exercising any rights or remedies under this Paragraph CITY shall not be required to competitively bid this work unless required by law.

C. Where CONTRACTOR's services have been so terminated by CITY, the termination will not affect any rights or remedies of CITY against CONTRACTOR then existing or which may thereafter accrue. Any retention or payment of moneys due CONTRACTOR by CITY will not release CONTRACTOR from liability.

D. If, after a default termination, it is determined that the CONTRACTOR was not in default, the rights and obligations of the parties shall be the same as if the termination had been issued for the convenience of the CITY. The CITY shall then be liable to CONTRACTOR for only those costs enumerated in paragraph 15.03.

15.03 CITY May Terminate for Convenience

A. Notwithstanding any other provision of this Contract, upon seven (7) calendar days written notice to CONTRACTOR, CITY may, at its sole and absolute discretion, without cause and without prejudice to any other right or remedy of CITY, elect to terminate the Contract. In such case, CONTRACTOR shall, with thirty (30) calendar days of receiving notice of termination under this paragraph, submit to CITY its statement of costs and expenses and shall be paid:

1. for completed and acceptable Work executed in accordance with the Contract Documents prior to the effective date of termination, including fair and reasonable sums for overhead and profit on such Work;

2. for expenses sustained prior to the effective date of termination in performing services and furnishing labor, materials or equipment as required by the Contract Documents in connection with uncompleted Work, plus fair and reasonable sums for overhead and profit on such expenses;

3. for all costs, losses and damages incurred in settlement of terminated contracts with Subcontractors, Suppliers and others; and

4. for reasonable expenses directly attributable to termination if approved in advance by CITY.

B. CONTRACTOR shall not be paid on account of loss of anticipated profits or revenue or other economic loss arising out of or resulting from such termination.

C. CONTRACTOR waives any costs not submitted to CITY pursuant to paragraph 15.03.A.

D. CITY shall, within thirty (30) calendar days after receipt of CONTRACTOR's statement, pay CONTRACTOR all amounts it determines are properly determined.

ARTICLE 16 CLAIMS AND DISPUTES

16.01 Definition

A. A Claim is a demand or assertion by the CONTRACTOR seeking, as a matter of right, the adjustment of Contract price and/or times with respect to the terms of the Contract.

16.02 Written Notice and Burden of Proof

A. Claims must be made by written notice pursuant to Paragraph 17.01. The written notice shall clearly indicate that the CONTRACTOR is making a claim. The responsibility to substantiate Claims shall rest with the CONTRACTOR. No Claim may be made under this Contract except as provided in this Article.

B. Certification of Claim: The written notice of Claim shall include the following statement signed by the CONTRACTOR's representative: "The CONTRACTOR certifies that all statements made and the facts set out in this claim are true and correct and that no false records have been submitted in support of this claim." **Strict compliance with this paragraph shall be a condition precedent to the creation, existence or validity of any Claim.**

16.03 Time Limits on Claims

A. The CONTRACTOR must give notice to the CITY within fourteen (14) calendar days after the denial of a request for or failure to reach an agreement on a change in Contract Price and/or change in Contract Time pursuant to Article 11 and Article 12 respectively. After the fourteen (14) day period for making Claims has expired, the Claim shall be considered waived.

B. The CONTRACTOR shall submit the Claim to the CITY's Representative.

16.04 Continuing Contract Performance

A. Pending final resolution of a Claim, unless otherwise agreed in writing, the CONTRACTOR shall proceed diligently with performance of the Work and the CITY shall continue to make payments in accordance with the Contract Documents. The CITY may, but is not obligated to, notify the Surety of the nature and amount of the Claim.

16.05 Injury or Damage to Person or Property

A. If either party to the Contract suffers injury or damage to person or property because of an act or omission of the other party, of any of the other party's employees or agents, or of others for whose acts that party is legally liable, written notice of the injury or damage, whether or not insured, shall be given to the other party within a reasonable time not exceeding thirty (30) days after first observance. The notice shall provide sufficient detail to enable the other party to investigate the matter.

16.06 Initial Resolution of Claims and Disputes

A. After the CONTRACTOR has submitted the Claim to the CITY'S Representative, the CITY'S Representative and CONTRACTOR'S Representative shall conduct a settlement conference within fourteen (14) calendar days from the date of receipt of the Claim. If the Claim is not settled within seven (7) calendar days following the date of the settlement conference, the CITY'S Representative and the CONTRACTOR's Representative shall state, in writing, following the conclusion of the seven (7) calendar day period, their respective position as to the matters in dispute.

B. The CITY'S and CONTRACTOR'S statement of positions shall state all known factual grounds for each party's position. If the dispute remains unresolved at the end of the seven (7) calendar days from submission of the parties' written position statements, the CONTRACTOR shall have the right to proceed with the pursuit of Claims pursuant to paragraph 16.07.

C. If a Claim has been resolved, the OWNER will prepare or obtain appropriate documentation.

16.07 Final Resolution of Claims and Disputes

A. All administrative procedures set forth in this contract must first be exhausted before suit is filed.

B. If the CITY'S Representative and the CONTRACTOR'S Representative are unable to resolve the dispute pursuant to 16.06, the parties must submit their statements of position to the Director, who shall review the Claim and make a decision within fourteen (14) calendar days.

C. Absent fraud, gross mistake or bad faith, the Director's decision shall be final and binding on CITY and CONTRACTOR within fourteen (14) calendar days after issuance. The CONTRACTOR shall give written notice to the CITY stating its intent to submit its Claim to a court of law pursuant to paragraph 17.05.A. within thirty (30) calendar days after notice of Director's decision.

D. The time frames for the Director's decision and for CONTRACTOR'S written notice of intent may be tolled by participation in voluntary mediation. Mediator selection and the procedures to be employed in voluntary mediation shall be mutually acceptable to the parties. Costs of the mediator shall be shared equally among the parties participating in the mediation. In no event shall any time frame be tolled more than 30 days for mediation. However, mediation may be employed at any time at the discretion and mutual agreement of the parties.

E. If the dispute is not resolved during voluntary mediation, The CONTRACTOR agrees that it will file no suit based on facts or evidentiary materials that were not presented for consideration to the CITY during the mediation process or of which the CONTRACTOR had knowledge and failed to present during the administrative procedures.

ARTICLE 17 MISCELLANEOUS

17.01 Giving Notice

A. Whenever any provision of the Contract Documents requires the giving of written notice, it will be given by personal delivery, by registered or certified mail, postage prepaid, to the last business address known to the giver of the notice or by confirmed electronic facsimile transmission. Notice is effective on the date of personal delivery, deposit of registered or certified mail, postage prepaid, or confirmed electronic facsimile transmission.

17.02 Computation of Times

A. When any period of time is referred to in the Contract Documents by days, it will be computed to exclude the first and include the last calendar day of such period. If the last day of such period falls on a Saturday or Sunday or on a day made a legal holiday by the law of the applicable jurisdiction, such day will be omitted from the computation.

17.03 Cumulative Remedies

A. The duties and obligations imposed by these General Conditions and the rights and remedies available hereunder to the parties hereto, and, in particular but without limitation, the

warranties, guarantees and obligations imposed upon CONTRACTOR and all of the rights and remedies available to CITY and DESIGN PROFESSIONAL hereunder are in addition to, and are not to be construed in any way as a limitation of, any rights and remedies available to any or all of them which are otherwise imposed or available by Laws or Regulations, by special warranty or guarantee or by other provisions of the Contract Documents, and the provisions of this Paragraph will be as effective as if repeated specifically in the Contract Documents in connection with each particular duty, obligation, right and remedy to which they apply.

17.04 Survival of Obligations

A. All representations, indemnifications, warranties, and guarantees made in, required by, or given in accordance with the Contract Documents, as well as all continuing obligations indicated in the Contract Documents will survive final payment, completion, and acceptance of the Work or termination or completion of the Contract.

17.05 Controlling Law

A. This Contract shall be construed and governed in accordance with the laws of the State of Missouri without giving effect to Missouri's choice of law provisions. The CITY and CONTRACTOR: (1) shall submit exclusively to the jurisdiction of the state and federal courts located in Jackson County, Missouri and no other; (2) shall waive any and all objections to jurisdiction and venue; and (3) shall not raise forum non conveniens as an objection to the location of any litigation.



SUPPLEMENTARY CONDITIONS

Project/Contract Number: 60XX0028/9835

Project Title WD Asphalt and Concrete, City Wide

These Supplementary Conditions amend or supplement the General Conditions of the Construction Contract and other provisions of the Contract Documents as indicated below. All provisions that are not so amended or supplemented remain in full force and effect.

SC-2.03 A. Article 2, Paragraph 2.03, Copies of Documents, is amended by deleting Paragraph 2.03 A and replacing it with the following:

- A. CITY shall furnish to CONTRACTOR one copy of the Drawings and Specifications, including Addenda.

In the preparation of the Contract Documents, no reports of explorations and tests of subsurface conditions at or contiguous to the Site of the Work were utilized.

In the preparation of the Contract Documents, no drawings of physical conditions in or relating to existing surface or subsurface structures which are at or contiguous to the Site of the Work were utilized.

SC-4.06 Article 4, Paragraph 4.06, Asbestos, Lead-Based Paint, PCBs, Petroleum Waste or Radioactive Material, Subparagraphs A and B are supplemented as follows:

In the preparation of the Contract Documents, no reports of explorations and tests of any Hazardous Environmental Condition(s) at the Site of the Work were utilized.

SC- 5.01 A. Article 5, Paragraph 5.01, Performance, Payment and Other Bonds, Subparagraph A, second sentence, is revised as follows:

These Bonds shall remain in effect at least until **two (2) years** after the date when final payment becomes due, except as provided otherwise by Laws or Regulations or by the Contract Documents.

SC-5.03 A. Article 5, Paragraph 5.03 Certificates of Insurance, Subparagraph A is amended by adding the following Subparagraph 1:

1. CONTRACTOR shall obtain evidence that all Subcontractors have in force the required coverage in the amounts required by these Contract Documents, and evidence that each is current on its unemployment insurance payments before Subcontractors begin Work at the Site. CONTRACTOR shall retain such evidence in its files and make available to CITY within ten (10) days after written request.

SC-5.06 A. Article 5, Paragraph 5.06, Property Insurance, is amended by deleting Subparagraph A and inserting the following:

- A. CONTRACTOR shall not be required to purchase and maintain property insurance on the Work at the Site.

SC-6.06 A.1 Article 6, Paragraph 6.06 Substitutes and "Or-Equal" Items, Paragraph A is amended by adding the following at the end of Paragraph A.1:

Proposed "or-equal" items must be submitted to CITY at least 8 days prior to Bid date at the following address:

4800 E 63rd Street
Kansas City, Missouri 64130
Attn: Todd Rohr, Project Manager

Only Bidders may submit proposed "or-equal" items and such items must require no change in related Work. Acceptance by CITY of any proposed "or-equal" items will be made by Addendum only.

SC-6.06 A.2. Article 6, Paragraph 6.06 Substitutes and "Or-Equal" Items, Paragraph A is amended by adding the following at the end of Paragraph A.2:

Proposed substitute items must be submitted to CITY's Representative not later than 8 days prior to the time the item is to be incorporated into the Work. Only CONTRACTOR may submit proposed substitute items, and such items must be submitted to CITY's Representative on the standard City form 01630 - Substitution Request. Acceptance by CITY of any proposed substitute item will be made by Change Order.

SC-6.07 B. Article 6, Paragraph 6.07, Concerning Subcontractors, Suppliers and Others, Subparagraph B is supplemented as follows:

The following Subcontractors, Suppliers or other persons or organizations (including those who are to furnish the principal items of materials or equipment) are to be submitted to CITY for acceptance, on or before the date stated.

SC-6.10. Article 6, Paragraph 6.10, Compliance with Laws and Regulations, is amended by adding the following new Subparagraphs immediately following Subparagraph 6.10 I 2:

a. CONTRACTOR will be required to comply with wage rates as follows:

County – Cass, Clay, Jackson, Platte

Work Type:

State – Heavy

SC-6.10. Article 6, Paragraph 6.10, Compliance with Laws and Regulations, is amended by adding the following new Subparagraph 6.10 S:

1. "Resident Laborers" means laborers who have been residents of the State of Missouri for at least thirty days and who intend to remain Missouri residents, and residents of Nonrestrictive States.

2. "Nonrestrictive States" means states identified by the Missouri Department of Labor and Industrial Relations Division of Labor Standards that have not enacted state laws restricting Missouri laborers from working on public works projects. A list of Nonrestrictive States can be found on the Division web site at <http://www.dolir.mo.gov/ls/index.htm>.

3. A period of Excessive Unemployment is declared when the Missouri Department of Labor and Industrial Relations Division of Labor Standards provides notice of such declaration. When in effect, notice will be provided on the Division web site at <http://www.dolir.mo.gov/ls/index.htm>. It is CONTRACTOR's obligation to determine whether a period of Excessive Unemployment is in effect when this Contract is let.

4. CONTRACTOR agrees to follow the provisions of Section 290.560 - 290.575 RSMo and agrees that if a period of Excessive Unemployment has been declared at any point during the term of this Contract, it will employ and require all Subcontractors of whatever tier to employ only Resident Laborers for the Work to be performed under this CONTRACT. Provided, however, CONTRACTOR may use laborers who are not Resident Laborers when Resident Laborers are not available or are incapable of performing the particular type of work involved if CONTRACTOR so certifies in writing to CITY and CITY issues a written approval. This provision does not apply to regularly employed nonresident executive, supervisory or technical employees.

SC-6.11. Article 6, Paragraph 6.11, Taxes, is amended by adding the following sentence to Subparagraph 6.11 B:

B. Tax Compliance. The following subparagraphs apply if the Contract is over \$160,000.00.

SC-11.04 A. Article 11, Paragraph 11.04, Unit Price Work, is amended by deleting Paragraph 11.04 and replacing Paragraph 11.04 with the following:

- A. The WORK includes an undetermined number of work sites depending on repairs performed by others over the term of the Contract that need restoration. Quantities specified in the Bid Forms are estimates only to be used in determining, the lowest and best bid. The quantities specified in the Bid Forms are not guaranteed by this Contract. If the Work does not amount to the quantities described in the Bid Forms, that fact shall not constitute the basis for a claim or adjustment of any Unit Price.
- B. Each unit price will be deemed to include an amount considered by CONTRACTOR to be adequate to cover CONTRACTOR's overhead and profit for each separately identified item.
- C. CONTRACTOR shall perform Unit Price Work specified in the Bid Forms, when and if ordered, at the established unit price for each separately identified item of Unit Price Work times the estimated quantity of each item as indicated in the Contract.
- D. Work may also include items that are not a part of the Unit Prices included in the Bid Forms.

SC-12.01 Article 12, Paragraph 12.01, Time of the Essence is amended by adding the following new Subparagraphs immediately following Subparagraph 12.01 A:

- A. Times stated in the Contract Documents are of the essence of the Contract. CONTRACTOR will likely have to work in less than ideal weather conditions in order to meet these performance requirements.
- B. Eighty percent of all Work Orders shall be completed within 8 business days and 100 percent of Work Orders shall be completed within 15 business days. Street Plate Embedment shall be completed within 5 business days. The start date shall be the next business day after a work order is assigned to the CONTRACTOR in the Hansen system. The date when the Work is considered to be complete shall be the date when the CONTRACTOR finishes the work and closes the work order in Hansen, as defined in Section 01100 – Summary of Work. A business day does not include weekends or City holidays, even if CONTRACTOR chooses to work on these days.
- C. Liquidated damages of \$50 per calendar day shall be assessed for each Work Order that fails to meet the requirements given in Paragraph SC -12.01.B and shall be assessed each calendar day thereafter until the work order has been completed. Liquidated damages of

\$150 per calendar day shall also be assessed per day that the street has not been reopened beyond two business days for each Rapid Response Work Order.

- D. Both parties realize that weather conditions may impede the schedule of some construction work. CONTRACTOR shall strive to meet these performance criteria in spite of normal year-round weather conditions. The CITY may suspend accrual of liquidated damages for an extended period of extreme weather. If extreme weather is encountered, it shall be responsibility of CONTRACTOR to demonstrate that additional completion time should be awarded as per Specification 00700, General Conditions.
- E. Whether any Work Orders are assessed liquidated damages and the amount thereof shall be based on a review of Work Orders and other required documentation. As part of the payment application, the CONTRACTOR shall calculate the percent of Work Orders that were completed within 8 business days and the percent of Work Orders that were completed within 15 business days. This calculation will be submitted electronically in Microsoft Excel format. Work Orders shall be invoiced in the next pay application following their completion. In some cases a particular Work Order may consist of more than one adjacent repair.
- F. Liquidated damages shall be deducted from the payment application on which the work order is identified or, if necessary, from other payments due the CONTRACTOR.
- G. The quantity of restoration Work Orders will vary from month-to-month. CITY has provided CONTRACTOR with historical work order volume by month so that CONTRACTOR can provide the necessary level of resources to perform the WORK. If the number of Work Orders in any month exceeds 1.25 times the historical average for that month, CITY will provide an additional two (2) business days for all Work Orders sent to the Contractor in that month. If the number of Work Orders in any month exceeds 1.5 times the historical average for that month, CITY will provide an additional four (4) business days for all Work Orders sent to the Contractor in that month.

Historical Number of Restoration Work Orders per Month

	Year							Avg.
	2017	2018	2019	2020	2021	2022	2023	
January	224	238	236	208	233	142	230	216
February	182	257	205	241	217	144	259	215
March	257	303	297	235	335	222	277	275
April	237	271	347	297	261	194	237	263
May	289	340	286	252	272	172	302	273
June	268	285	307	264	281	226	249	269
July	225	354	296	233	263	170	210	250
August	320	347	309	246	260	222	288	285
September	212	286	351	285	214	174	210	247
October	217	186	262	303	227	295	266	251
November	234	261	267	232	210	207		235
December	164	254	204	274	136	156		198

- H. Performance Incentive: If, during any invoice period, the average completion time of all the Work Orders in the payment application is 8.0 business days or less, the CITY will pay CONTRACTOR an additional one percent of the original approved invoice amount as a reward for prompt completion. If the average completion time of all the Work Orders in the payment application is 6.5 business days or less, CITY will pay CONTRACTOR an additional one percent of the original approved invoice amount (for a total of two percent). If the average completion time of all the Work Orders in the payment application is 5 business days or less, CITY will pay CONTRACTOR an additional one percent of the original approved invoice amount (for a total of three percent).
- I. The Work shall be completed and ready for final payment in accordance with Paragraph 14.07 within 365 Calendar Days after the date of Notice to Proceed, unless extended by a change order.

SC-13.07 Article 13, Paragraph 13.07, Correction Period, Subparagraph A is amended as follows:

The correction period set forth in Paragraph 13.07 A shall be two (2) years instead of one (1) year, which longer period of time shall also be applicable to the correction period set forth in Paragraph 13.07 C. All other provisions of Paragraph 13.07 remain unchanged except as necessary to accommodate the revised length of the correction period.

SC-14.02 A. Article 14, Paragraph 14.02, Application for Progress Payments, Subparagraph A is amended by deleting Item 3 and adding the following:

- 3. CITY shall make payments to CONTRACTOR monthly on or about the 15th day of each month. Payments to CONTRACTOR will be made on the basis of ninety-seven percent (97%) of the value of the Work satisfactorily completed plus ninety-seven percent (97%) of the value of properly stored and insured, unused materials on hand on the Site of the Work. CITY shall retain three percent (3%) of each partial payment until completion and acceptance of the Work covered by the Contract and final payment is due. All Work covered by a payment becomes CITY's property, provided that the Work paid for remains the sole responsibility of CONTRACTOR until all terms and conditions of the Contract have been met.

SECTION 00830

PREVAILING WAGE

1. Annual Wage Order No. 31
2. **0830.03 Division of Labor Standards Rules & Regulations** are incorporated into and made part of this Contract and are available at <http://s1.sos.mo.gov/cmsimages/adrules/csr/current/8csr/8c30-3.pdf>.

Missouri

Division of Labor Standards

WAGE AND HOUR SECTION

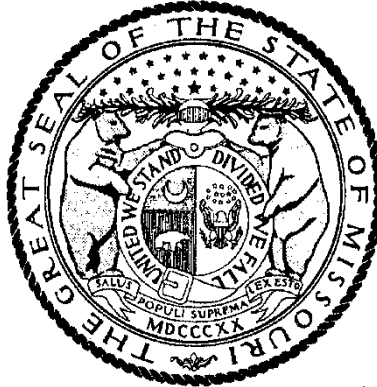

MICHAEL L. PARSON, Governor

Annual Wage Order No. 31

Section 019
CASS COUNTY

In accordance with Section 290.262 RSMo 2000, within thirty (30) days after a certified copy of this Annual Wage Order has been filed with the Secretary of State as indicated below, any person who may be affected by this Annual Wage Order may object by filing an objection in triplicate with the Labor and Industrial Relations Commission, P.O. Box 599, Jefferson City, MO 65102-0599. Such objections must set forth in writing the specific grounds of objection. Each objection shall certify that a copy has been furnished to the Division of Labor Standards, P.O. Box 449, Jefferson City, MO 65102-0449 pursuant to 8 CSR 20-5.010(1). A certified copy of the Annual Wage Order has been filed with the Secretary of State of Missouri.

Original Signed by _____

Todd Smith, Director
Division of Labor Standards

Filed With Secretary of State: _____ **March 8, 2024**

Last Date Objections May Be Filed: **April 8, 2024**

Prepared by Missouri Department of Labor and Industrial Relations

Building Construction Rates for
CASS County

Section 019

OCCUPATIONAL TITLE	**Prevailing Hourly Rate
Asbestos Worker	\$69.76
Boilermaker	\$27.07*
Bricklayer-Stone Mason	\$62.58
Carpenter	\$65.51
Lather	
Linoleum Layer	
Millwright	
Pile Driver	
Cement Mason	\$27.07*
Plasterer	
Communication Technician	\$60.00
Electrician (Inside Wireman)	\$70.56
Electrician Outside Lineman	\$27.07*
Lineman Operator	
Lineman - Tree Trimmer	
Groundman	
Groundman - Tree Trimmer	
Elevator Constructor	\$27.07*
Glazier	\$27.07*
Ironworker	\$69.62
Laborer	\$53.58
General Laborer	
First Semi-Skilled	
Second Semi-Skilled	
Mason	\$27.07*
Marble Mason	
Marble Finisher	
Terrazzo Worker	
Terrazzo Finisher	
Tile Setter	
Tile Finisher	
Operating Engineer	\$63.62
Group I	
Group II	
Group III	
Group III-A	
Group IV	
Group V	
Painter	\$27.07*
Plumber	\$79.79
Pipe Fitter	
Roofer	\$60.03
Sheet Metal Worker	\$76.56
Sprinkler Fitter	\$27.07*
Truck Driver	\$27.07*
Truck Control Service Driver	
Group I	
Group II	
Group III	
Group IV	

*The Division of Labor Standards received fewer than 1,000 reportable hours for this occupational title. The public works contracting minimum wage is established for this occupational title using data provided by Missouri Economic Research and Information Center.

**The Prevailing Hourly Rate includes any applicable fringe benefit amounts for each occupational title as defined in RSMo Section 290.210.

Heavy Construction Rates for
CASS County

Section 019

OCCUPATIONAL TITLE	**Prevailing Hourly Rate
Carpenter	\$27.07*
Millwright	
Pile Driver	
Electrician (Outside Lineman)	\$27.07*
Lineman Operator	
Lineman - Tree Trimmer	
Groundman	
Groundman - Tree Trimmer	
Laborer	\$51.69
General Laborer	
Skilled Laborer	
Operating Engineer	\$59.65
Group I	
Group II	
Group III	
Group IV	
Truck Driver	\$27.07*
Truck Control Service Driver	
Group I	
Group II	
Group III	
Group IV	

Use Heavy Construction Rates on Highway and Heavy construction in accordance with the classifications of construction work established in 8 CSR 30-3.040(3).

Use Building Construction Rates on Building construction in accordance with the classifications of construction work established in 8 CSR 30-3.040(2).

If a worker is performing work on a heavy construction project within an occupational title that is not listed on the Heavy Construction Rate Sheet, use the rate for that occupational title as shown on the Building Construction Rate Sheet.

*The Division of Labor Standards received fewer than 1,000 reportable hours for this occupational title. Public works contracting minimum wage is established for this occupational title using data provided by Missouri Economic Research and Information Center.

**The Prevailing Hourly Rate includes any applicable fringe benefit amounts for each occupational title.

Missouri

Division of Labor Standards

WAGE AND HOUR SECTION

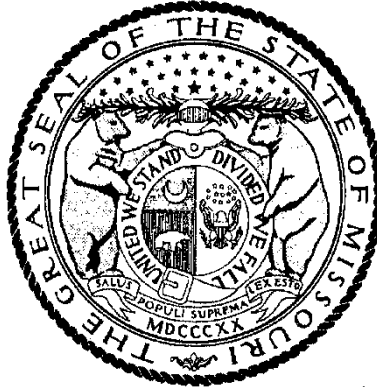

MICHAEL L. PARSON, Governor

Annual Wage Order No. 31

Section 024
CLAY COUNTY

In accordance with Section 290.262 RSMo 2000, within thirty (30) days after a certified copy of this Annual Wage Order has been filed with the Secretary of State as indicated below, any person who may be affected by this Annual Wage Order may object by filing an objection in triplicate with the Labor and Industrial Relations Commission, P.O. Box 599, Jefferson City, MO 65102-0599. Such objections must set forth in writing the specific grounds of objection. Each objection shall certify that a copy has been furnished to the Division of Labor Standards, P.O. Box 449, Jefferson City, MO 65102-0449 pursuant to 8 CSR 20-5.010(1). A certified copy of the Annual Wage Order has been filed with the Secretary of State of Missouri.

Original Signed by _____

Todd Smith, Director
Division of Labor Standards

Filed With Secretary of State: _____ **March 8, 2024**

Last Date Objections May Be Filed: **April 8, 2024**

Prepared by Missouri Department of Labor and Industrial Relations

Building Construction Rates for
CLAY County

Section 024

OCCUPATIONAL TITLE	**Prevailing Hourly Rate
Asbestos Worker	\$70.59
Boilermaker	\$35.51*
Bricklayer-Stone Mason	\$62.37
Carpenter	\$64.44
Lather	
Linoleum Layer	
Millwright	
Pile Driver	
Cement Mason	\$56.58
Plasterer	
Communication Technician	\$61.30
Electrician (Inside Wireman)	\$68.72
Electrician Outside Lineman	\$35.51*
Lineman Operator	
Lineman - Tree Trimmer	
Groundman	
Groundman - Tree Trimmer	
Elevator Constructor	\$35.51*
Glazier	\$58.94
Ironworker	\$69.61
Laborer	\$50.47
General Laborer	
First Semi-Skilled	
Second Semi-Skilled	
Mason	\$56.70
Marble Mason	
Marble Finisher	
Terrazzo Worker	
Terrazzo Finisher	
Tile Setter	
Tile Finisher	
Operating Engineer	\$63.28
Group I	
Group II	
Group III	
Group III-A	
Group IV	
Group V	
Painter	\$56.98
Plumber	\$78.98
Pipe Fitter	
Roofer	\$59.93
Sheet Metal Worker	\$75.64
Sprinkler Fitter	\$71.38
Truck Driver	\$56.61
Truck Control Service Driver	
Group I	
Group II	
Group III	
Group IV	

*The Division of Labor Standards received fewer than 1,000 reportable hours for this occupational title. The public works contracting minimum wage is established for this occupational title using data provided by Missouri Economic Research and Information Center.

**The Prevailing Hourly Rate includes any applicable fringe benefit amounts for each occupational title as defined in RSMo Section 290.210.

Heavy Construction Rates for
CLAY County

Section 024

OCCUPATIONAL TITLE	**Prevailing Hourly Rate
Carpenter	\$64.52
Millwright	
Pile Driver	
Electrician (Outside Lineman)	\$35.51*
Lineman Operator	
Lineman - Tree Trimmer	
Groundman	
Groundman - Tree Trimmer	
Laborer	\$51.51
General Laborer	
Skilled Laborer	
Operating Engineer	\$55.82
Group I	
Group II	
Group III	
Group IV	
Truck Driver	\$51.36
Truck Control Service Driver	
Group I	
Group II	
Group III	
Group IV	

Use Heavy Construction Rates on Highway and Heavy construction in accordance with the classifications of construction work established in 8 CSR 30-3.040(3).

Use Building Construction Rates on Building construction in accordance with the classifications of construction work established in 8 CSR 30-3.040(2).

If a worker is performing work on a heavy construction project within an occupational title that is not listed on the Heavy Construction Rate Sheet, use the rate for that occupational title as shown on the Building Construction Rate Sheet.

*The Division of Labor Standards received fewer than 1,000 reportable hours for this occupational title. Public works contracting minimum wage is established for this occupational title using data provided by Missouri Economic Research and Information Center.

**The Prevailing Hourly Rate includes any applicable fringe benefit amounts for each occupational title.

OVERTIME and HOLIDAYS

OVERTIME

For all work performed on a Sunday or a holiday, not less than twice (2x) the prevailing hourly rate of wages for work of a similar character in the locality in which the work is performed or the public works contracting minimum wage, whichever is applicable, shall be paid to all workers employed by or on behalf of any public body engaged in the construction of public works, exclusive of maintenance work.

For all overtime work performed, not less than one and one-half (1½) the prevailing hourly rate of wages for work of a similar character in the locality in which the work is performed or the public works contracting minimum wage, whichever is applicable, shall be paid to all workers employed by or on behalf of any public body engaged in the construction of public works, exclusive of maintenance work or contractual obligation. For purposes of this subdivision, "**overtime work**" shall include work that exceeds ten hours in one day and work in excess of forty hours in one calendar week; and

A thirty-minute lunch period on each calendar day shall be allowed for each worker on a public works project, provided that such time shall not be considered as time worked.

HOLIDAYS

January first;
The last Monday in May;
July fourth;
The first Monday in September;
November eleventh;
The fourth Thursday in November; and
December twenty-fifth;

If any holiday falls on a Sunday, the following Monday shall be considered a holiday.

OVERTIME and HOLIDAYS

OVERTIME

For all work performed on a Sunday or a holiday, not less than twice (2x) the prevailing hourly rate of wages for work of a similar character in the locality in which the work is performed or the public works contracting minimum wage, whichever is applicable, shall be paid to all workers employed by or on behalf of any public body engaged in the construction of public works, exclusive of maintenance work.

For all overtime work performed, not less than one and one-half (1½) the prevailing hourly rate of wages for work of a similar character in the locality in which the work is performed or the public works contracting minimum wage, whichever is applicable, shall be paid to all workers employed by or on behalf of any public body engaged in the construction of public works, exclusive of maintenance work or contractual obligation. For purposes of this subdivision, "**overtime work**" shall include work that exceeds ten hours in one day and work in excess of forty hours in one calendar week; and

A thirty-minute lunch period on each calendar day shall be allowed for each worker on a public works project, provided that such time shall not be considered as time worked.

HOLIDAYS

January first;
The last Monday in May;
July fourth;
The first Monday in September;
November eleventh;
The fourth Thursday in November; and
December twenty-fifth;

If any holiday falls on a Sunday, the following Monday shall be considered a holiday.

Missouri

Division of Labor Standards

WAGE AND HOUR SECTION

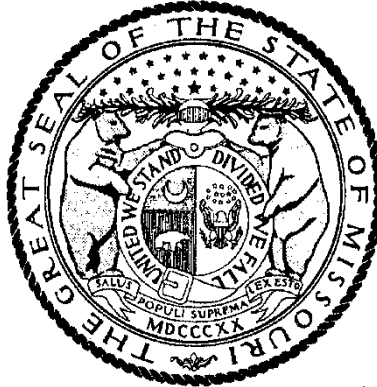

MICHAEL L. PARSON, Governor

Annual Wage Order No. 31

Section 048
JACKSON COUNTY

In accordance with Section 290.262 RSMo 2000, within thirty (30) days after a certified copy of this Annual Wage Order has been filed with the Secretary of State as indicated below, any person who may be affected by this Annual Wage Order may object by filing an objection in triplicate with the Labor and Industrial Relations Commission, P.O. Box 599, Jefferson City, MO 65102-0599. Such objections must set forth in writing the specific grounds of objection. Each objection shall certify that a copy has been furnished to the Division of Labor Standards, P.O. Box 449, Jefferson City, MO 65102-0449 pursuant to 8 CSR 20-5.010(1). A certified copy of the Annual Wage Order has been filed with the Secretary of State of Missouri.

Original Signed by _____

Todd Smith, Director
Division of Labor Standards

Filed With Secretary of State: _____ **March 8, 2024**

Last Date Objections May Be Filed: **April 8, 2024**

Prepared by Missouri Department of Labor and Industrial Relations

OCCUPATIONAL TITLE	**Prevailing Hourly Rate
Asbestos Worker	\$69.50
Boilermaker	\$39.44*
Bricklayer-Stone Mason	\$62.06
Carpenter	\$64.94
Lather	
Linoleum Layer	
Millwright	
Pile Driver	
Cement Mason	\$58.02
Plasterer	
Communication Technician	\$62.38
Electrician (Inside Wireman)	\$70.32
Electrician Outside Lineman	\$61.40
Lineman Operator	
Lineman - Tree Trimmer	
Groundman	
Groundman - Tree Trimmer	
Elevator Constructor	\$93.11
Glazier	\$59.07
Ironworker	\$70.66
Laborer	\$52.42
General Laborer	
First Semi-Skilled	
Second Semi-Skilled	
Mason	\$50.24
Marble Mason	
Marble Finisher	
Terrazzo Worker	
Terrazzo Finisher	
Tile Setter	
Tile Finisher	
Operating Engineer	\$66.05
Group I	
Group II	
Group III	
Group III-A	
Group IV	
Group V	
Painter	\$54.25
Plumber	\$78.88
Pipe Fitter	
Roofer	\$60.69
Sheet Metal Worker	\$76.38
Sprinkler Fitter	\$69.92
Truck Driver	\$54.27
Truck Control Service Driver	
Group I	
Group II	
Group III	
Group IV	

*The Division of Labor Standards received fewer than 1,000 reportable hours for this occupational title. The public works contracting minimum wage is established for this occupational title using data provided by Missouri Economic Research and Information Center.

**The Prevailing Hourly Rate includes any applicable fringe benefit amounts for each occupational title as defined in RSMo Section 290.210.

Heavy Construction Rates for
JACKSON County

Section 048

OCCUPATIONAL TITLE	**Prevailing Hourly Rate
Carpenter	\$65.11
Millwright	
Pile Driver	
Electrician (Outside Lineman)	\$90.71
Lineman Operator	
Lineman - Tree Trimmer	
Groundman	
Groundman - Tree Trimmer	
Laborer	\$51.85
General Laborer	
Skilled Laborer	
Operating Engineer	\$60.48
Group I	
Group II	
Group III	
Group IV	
Truck Driver	\$53.04
Truck Control Service Driver	
Group I	
Group II	
Group III	
Group IV	

Use Heavy Construction Rates on Highway and Heavy construction in accordance with the classifications of construction work established in 8 CSR 30-3.040(3).

Use Building Construction Rates on Building construction in accordance with the classifications of construction work established in 8 CSR 30-3.040(2).

If a worker is performing work on a heavy construction project within an occupational title that is not listed on the Heavy Construction Rate Sheet, use the rate for that occupational title as shown on the Building Construction Rate Sheet.

*The Division of Labor Standards received fewer than 1,000 reportable hours for this occupational title. Public works contracting minimum wage is established for this occupational title using data provided by Missouri Economic Research and Information Center.

**The Prevailing Hourly Rate includes any applicable fringe benefit amounts for each occupational title.

OVERTIME and HOLIDAYS

OVERTIME

For all work performed on a Sunday or a holiday, not less than twice (2x) the prevailing hourly rate of wages for work of a similar character in the locality in which the work is performed or the public works contracting minimum wage, whichever is applicable, shall be paid to all workers employed by or on behalf of any public body engaged in the construction of public works, exclusive of maintenance work.

For all overtime work performed, not less than one and one-half (1½) the prevailing hourly rate of wages for work of a similar character in the locality in which the work is performed or the public works contracting minimum wage, whichever is applicable, shall be paid to all workers employed by or on behalf of any public body engaged in the construction of public works, exclusive of maintenance work or contractual obligation. For purposes of this subdivision, "**overtime work**" shall include work that exceeds ten hours in one day and work in excess of forty hours in one calendar week; and

A thirty-minute lunch period on each calendar day shall be allowed for each worker on a public works project, provided that such time shall not be considered as time worked.

HOLIDAYS

January first;
The last Monday in May;
July fourth;
The first Monday in September;
November eleventh;
The fourth Thursday in November; and
December twenty-fifth;

If any holiday falls on a Sunday, the following Monday shall be considered a holiday.

Missouri

Division of Labor Standards

WAGE AND HOUR SECTION

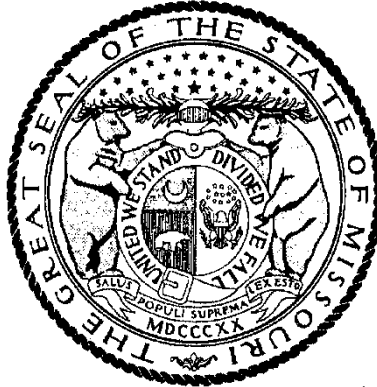

MICHAEL L. PARSON, Governor

Annual Wage Order No. 31

Section 083
PLATTE COUNTY

In accordance with Section 290.262 RSMo 2000, within thirty (30) days after a certified copy of this Annual Wage Order has been filed with the Secretary of State as indicated below, any person who may be affected by this Annual Wage Order may object by filing an objection in triplicate with the Labor and Industrial Relations Commission, P.O. Box 599, Jefferson City, MO 65102-0599. Such objections must set forth in writing the specific grounds of objection. Each objection shall certify that a copy has been furnished to the Division of Labor Standards, P.O. Box 449, Jefferson City, MO 65102-0449 pursuant to 8 CSR 20-5.010(1). A certified copy of the Annual Wage Order has been filed with the Secretary of State of Missouri.

Original Signed by _____

Todd Smith, Director
Division of Labor Standards

Filed With Secretary of State: _____ **March 8, 2024**

Last Date Objections May Be Filed: **April 8, 2024**

Prepared by Missouri Department of Labor and Industrial Relations

Building Construction Rates for
PLATTE County

Section 083

OCCUPATIONAL TITLE	**Prevailing Hourly Rate
Asbestos Worker	\$70.89
Boilermaker	\$33.79*
Bricklayer-Stone Mason	\$62.40
Carpenter	\$64.93
Lather	
Linoleum Layer	
Millwright	
Pile Driver	
Cement Mason	\$33.79*
Plasterer	
Communication Technician	\$65.26
Electrician (Inside Wireman)	\$70.09
Electrician Outside Lineman	\$33.79*
Lineman Operator	
Lineman - Tree Trimmer	
Groundman	
Groundman - Tree Trimmer	
Elevator Constructor	\$33.79*
Glazier	\$33.79*
Ironworker	\$69.26
Laborer	\$47.89
General Laborer	
First Semi-Skilled	
Second Semi-Skilled	
Mason	\$53.08
Marble Mason	
Marble Finisher	
Terrazzo Worker	
Terrazzo Finisher	
Tile Setter	
Tile Finisher	
Operating Engineer	\$63.82
Group I	
Group II	
Group III	
Group III-A	
Group IV	
Group V	
Painter	\$33.79*
Plumber	\$77.57
Pipe Fitter	
Roofer	\$60.39
Sheet Metal Worker	\$75.86
Sprinkler Fitter	\$33.79*
Truck Driver	\$33.79*
Truck Control Service Driver	
Group I	
Group II	
Group III	
Group IV	

*The Division of Labor Standards received fewer than 1,000 reportable hours for this occupational title. The public works contracting minimum wage is established for this occupational title using data provided by Missouri Economic Research and Information Center.

**The Prevailing Hourly Rate includes any applicable fringe benefit amounts for each occupational title as defined in RSMo Section 290.210.

Heavy Construction Rates for
PLATTE County

Section 083

OCCUPATIONAL TITLE	**Prevailing Hourly Rate
Carpenter	\$33.79*
Millwright	
Pile Driver	
Electrician (Outside Lineman)	\$33.79*
Lineman Operator	
Lineman - Tree Trimmer	
Groundman	
Groundman - Tree Trimmer	
Laborer	\$51.05
General Laborer	
Skilled Laborer	
Operating Engineer	\$60.01
Group I	
Group II	
Group III	
Group IV	
Truck Driver	\$53.04
Truck Control Service Driver	
Group I	
Group II	
Group III	
Group IV	

Use Heavy Construction Rates on Highway and Heavy construction in accordance with the classifications of construction work established in 8 CSR 30-3.040(3).

Use Building Construction Rates on Building construction in accordance with the classifications of construction work established in 8 CSR 30-3.040(2).

If a worker is performing work on a heavy construction project within an occupational title that is not listed on the Heavy Construction Rate Sheet, use the rate for that occupational title as shown on the Building Construction Rate Sheet.

*The Division of Labor Standards received fewer than 1,000 reportable hours for this occupational title. Public works contracting minimum wage is established for this occupational title using data provided by Missouri Economic Research and Information Center.

**The Prevailing Hourly Rate includes any applicable fringe benefit amounts for each occupational title.

OVERTIME and HOLIDAYS

OVERTIME

For all work performed on a Sunday or a holiday, not less than twice (2x) the prevailing hourly rate of wages for work of a similar character in the locality in which the work is performed or the public works contracting minimum wage, whichever is applicable, shall be paid to all workers employed by or on behalf of any public body engaged in the construction of public works, exclusive of maintenance work.

For all overtime work performed, not less than one and one-half (1½) the prevailing hourly rate of wages for work of a similar character in the locality in which the work is performed or the public works contracting minimum wage, whichever is applicable, shall be paid to all workers employed by or on behalf of any public body engaged in the construction of public works, exclusive of maintenance work or contractual obligation. For purposes of this subdivision, "**overtime work**" shall include work that exceeds ten hours in one day and work in excess of forty hours in one calendar week; and

A thirty-minute lunch period on each calendar day shall be allowed for each worker on a public works project, provided that such time shall not be considered as time worked.

HOLIDAYS

January first;
The last Monday in May;
July fourth;
The first Monday in September;
November eleventh;
The fourth Thursday in November; and
December twenty-fifth;

If any holiday falls on a Sunday, the following Monday shall be considered a holiday.



REQUEST FOR INTERPRETATION

Project Number _____

Project Title _____

Contractor _____

RFI Number _____ Date _____

From: _____

To: _____

Re: _____

Spec. Sec. Ref:

Paragraph:

Drawing Ref:

Detail:

Signed: _____

Response: _____

Attachments

Response From:

To:

Date Transmitted: _____ Date Rec'd: _____

Signed: _____

Design Professional

Signed: _____

Owner's Representative

- Distribution:
- Owner
 - Contractor
 - Construction Manager
 - Design Professional
 - Consultant _____
 - Other _____

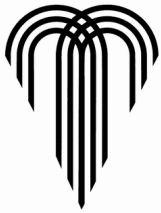

SUPPLEMENTAL DESIGN INSTRUCTION

Project Number _____

Project Title _____

To Contractor _____

From: _____ SDI No _____ Issue Date: _____

The Work shall be carried out in accordance with the following supplemental instructions issued in accordance with the Contract Documents without change in Contract Price or Contract Times. Proceeding with the Work in accordance with these instructions indicates your acknowledgement that there will be no change in the Contract Price or Contract Times.

Description:

Attachments (*List*)

(Signature) Design Professional

Date

- Distribution:
- Owner
 - Contractor
 - Construction Manager
 - Design Professional
 - Consultant _____
 - Other _____



REQUEST FOR PROPOSAL

Project Number _____

Project Title _____

To Contractor _____

From: _____ RFP No _____ Issue Date: _____

Please submit an itemized proposal for changes in the Contract Price and Contract Times for proposed modifications to the Contract Documents described herein. Submit proposal within _____ days, or notify the Owner in writing of the date on which you anticipate submitting your proposal.

This is NOT a Change Order, a Work Change Directive or a direction to proceed with the work described in the proposed modifications.

Description:

Attachments

Prepared by Design Professional

Prepared by Construction Manager

REQUESTED by OWNER'S Representative

- Distribution:
- Owner
 - Contractor
 - Construction Manager
 - Design Professional
 - Consultant _____
 - Other _____

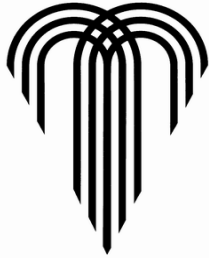

CHANGE ORDER

Project Number 60XX0028/9835

Project Title WD Asphalt and Concrete

Change Order No: One Date of Issuance: 10/14/2024

Ordinance No: 231024 Ordinance Effective Date: 12/24/2023

Contract Notice To Proceed Date: 11/1/2024

To CONTRACTOR: Superior Bowen Asphalt Co. LLC

The Contract is changed as follows: Change order of \$750,000

Work to be done is for the restoration of Engineering Water Main Replacement contracts.

This Change Order constitutes compensation in full on behalf of the Contractor and its subcontractors and suppliers for all costs, including impact costs and extended general conditions, and markups directly and indirectly attributable to the Work changes ordered herein, for all delays related thereto and for performance of the changes within the time stated. Contractor hereby releases all claims for delay, interruption, extended general conditions, impact and cumulative impact claims for this Work.

See Attached Document(s). N/A

Not valid until signed by the Director of Finance.

The original Contract Price was	<u>\$7,500,000.00</u>
Net change by previously authorized Change Orders	<u>\$0.00</u>
The Contract Price prior to this Change Order was	<u>\$7,500,000.00</u>
The Contract Price will be (<input type="checkbox"/> increased by) (<input type="checkbox"/> decreased by) (<input type="checkbox"/> unchanged)	<u>\$750,000.00</u>
The new Contract Price including this Change Order will be	<u>\$8,250,000.00</u>
[Note: If revised, establish and enter new dates. If unchanged, enter current contract dates.	
If you are only changing the Final Completion date, add the following reference:	
"The Contract Time for Final Completion will be . . ."]	
The Contract Time will be (X increased by) (<input type="checkbox"/> decreased by) (<input type="checkbox"/> unchanged)	<u>(0) calendar days</u>
The date of Substantial Completion as of the date of this Change Order therefore is	<u>N/A</u>
The date of Final Completion as of the date of this Change Order therefore is	<u>N/A</u>

Project No. & Title; 600XX0028/9835 WD Asphalt and Concrete
 Change Order No. One

DESIGN PROFESSIONAL:	By: N/A	Date:
	Title:	
CONTRACTOR:	By: Matt Bowen	Date:
<u>Superior Bowen Asphalt Co. LLC</u>	Title: COO	
CITY:	By: Jeff Martin	Date:
<u>City of Kansas City, MO</u> <u>Water Services</u>	Title: Deputy Director	

Approved as to form: _____
 Assistant City Attorney

[Note: If this CO does not change the Contract Price, delete the cert. of funds by Finance Director but send signed copy to Finance.]

I certify there is a balance otherwise unencumbered to the credit of the appropriation to which the above amount is chargeable, and a cash balance otherwise unencumbered in the treasury to the credit of the fund from which payment is to be made, each sufficient to meet the above obligation.

By: _____
 Director of Finance Date

Distribution: X CITY
 X CONTRACTOR
 DESIGN PROFESSIONAL

REMINDER: CONTRACTOR is responsible for considering the effect this Change Order may have on its ability to meet or exceed the D/M/WBE participation amounts in its Contractor Utilization Plan (CUP) as amended by any previously approved Request for Modification/Substitution. If CONTRACTOR will not be able to achieve the approved participation amounts in performing the work included within this Change Order, or if CONTRACTOR needs to retain the services of additional D/M/WBEs not previously listed in its CUP, CONTRACTOR is advised to submit a Request for Modification/Substitution.



WORK CHANGE DIRECTIVE

Project Number _____

Project Title _____

No.: _____ Date of Issuance: _____

TO:
(CONTRACTOR)

You are directed to proceed promptly with the following work:

Description:

Purpose of Work Change Directive:

Attachments: *(List documents supporting change)*

If the above work results on a change in the Contract Price or Contract Times, any request for a Change Order based thereon will involve one or more of the following methods of determining the effect of the change(s).

Method of determining change in
Contract Price:

Method of determining change in
Contract Times:

- Unit Prices
- Lump Sum
- As Stipulated in General Conditions
- Other _____

- CONTRACTOR's Records
- DESIGN PROFESSIONAL's Records
- City's Records
- Other _____

Estimated increase (decrease) in Contract Price:
\$ _____

Estimated increase (decrease) in Contract Times:
Substantial Completion: _____ days;

If the change involves an increase, the estimated Amount is not to be exceeded without further authorization.

Final Completion: _____ days.
If the change involves an increase, the estimated times are not to be exceeded without further authorization.

Recommended:

Recommended:

Recommended:

DESIGN PROFESSIONAL

Construction Manager

City

By (Authorized Signature)

By (Authorized Signature)

By (Authorized Signature)

- Distribution:
- City
 - Contractor
 - Construction Manager

- Design Professional
- Consultant
- Other

WORK CHANGE DIRECTIVE (“WCD”) INSTRUCTIONS

[Note: Do not attach these instructions to the WCD Form]

A. GENERAL INFORMATION

This document was developed for use in situations involving changes in the Work which, if not processed expeditiously, might delay the Project. These changes are often initiated in the field and may affect the Contract Price or the Contract Times. This is not a Change Order, but only a directive to proceed with Work that may be included in a subsequent Change Order. If the WCD may result in an increase in the Contract Price, a contract impact cost analysis must be performed prior to issuing the WCD. Availability of funds and authorization to expend funds must be part of the analysis.

For supplemental instructions and minor changes not involving a possible change in the Contract Price or the Contract Times a Supplemental Design Instruction may be used.

B. COMPLETING THE WORK CHANGE DIRECTIVE FORM

Based on conversations between Design Professional, City’s Representative and CONTRACTOR, Design Professional must complete the following:

DESCRIPTION: shall include a summary of the Work included in the WCD. Additional information may be attached to the WCD to further define the scope.

PURPOSE OF WORK CHANGE DIRECTIVE: will identify clearly if the Work included in the WCD is an addition, deletion, revision, or some combination.

ATTACHMENTS: shall identify all attachments included in and made a part of the WCD. Be certain that attachments are clearly labeled.

METHOD OF DETERMINING CHANGE, IF ANY, IN CONTRACT PRICE: Mark the method to be used in determining the final cost of Work involved and the estimated net effect on the Contract Price. If the change involves an increase in the Contract Price and the estimated amount is approached before the additional or changed Work is completed, another WCD must be issued to change the estimated price. Do not leave blank spaces or write “To be determined” (or “TBD”). An estimated dollar figure must be assigned to the Work. If the WCD is not likely to change the Contract Price, the space for estimated increase (decrease) should be marked “No Change in Price”.

METHOD OF DETERMINING CHANGE, IF ANY, IN CONTRACT TIMES: Mark the method to be used in determining the change in Contract Times and the estimated increase or decrease in Contract Times. If the change involves an increase in the Contract Times and the estimated times are approached before the additional or changed Work is completed, another WCD must be issued to change the times or CONTRACTOR may stop the changed Work when the estimated times are reached. Do not leave blank spaces or write “To be determined” (or “TBD”). If the WCD is not likely to change the Contract Times, the space for estimated increase (decrease) should be marked “No Change in Times”.

Once Design Professional has completed and signed the form, all copies should be sent to CITY for authorization because Design Professional does not have authority to authorize changes in Price or Times. Once authorized by CITY, a copy must be sent by Design Professional to CONTRACTOR. Price and Times may only be changed by Change Order signed by CITY, Design Professional, and CONTRACTOR. If the value of the work included in the WCD exceeds the contingency or budget available for the contract, staff must obtain written approval from the Director or his or her designee before the WCD is issued. A Director or his or her designee may not approve a WCD that will exceed City Council authorization. If the work included in the WCD is needed as a result of an emergency, staff may proceed with the issuance of the WCD without

prior written approval even if the value of the work added is expected to exceed the contract contingency balance.

Once the Work covered by this directive is completed or final cost and times are determined. CONTRACTOR must submit proper documentation for inclusion in a Change Order.

IF THIS IS A DIRECTIVE TO PROCEED WITH A CHANGE THAT MAY AFFECT THE CONTRACT PRICE OR THE CONTRACT TIMES A CHANGE ORDER, IF ANY, MUST BE PROCESSED PROMPTLY.

SECTION 1100 - SUMMARY OF WORK/PROJECT REQUIREMENTS

Project Description:

The Work is a public improvement primarily located in Cass, Clay, Jackson and Platte counties to restore areas damaged due to water main breaks, sanitary sewer repairs, stormwater repairs, and repair of deteriorated areas at other Water Services Department facilities. The items of Work and the basis of payment are as listed on the Unit Price Form.

The Work generally consists of repairing Water Services Department street cuts on streets, repairing adjacent curbs, sidewalks, driveways, yards, and other site-specific work as needed. The Work in this contract will consist of a large number of individual work sites located around the city. New work orders assigned to CONTRACTOR each day and the quantity of work will change over time depending on the number of repairs being done by the Water Services Department and its other contractors.

CONTRACTOR should assume that some excavation and hauling work will be required at each work location. CONTRACTOR'S unit prices should include provision for excavation and hauling work at each location.

In addition to line maintenance repair site, other restoration work may be done at Water Services Department facilities as part of this work, as directed by CITY. All work shall conform to the specifications contained in or referenced by this contract.

City reserves the right to contract with one or more additional companies providing restoration materials or services during the term of this Agreement and will not be obligated to utilize this Contractor over another provider. Whether and to what extent one or more companies are utilized by the City is solely within the City's discretion.

Work in General:

Work for this Contract shall be done on an on-call basis and the number and scope of Work Orders varies over time. Time is of the essence to complete each Work Order. CONTRACTOR shall respond to the Work Orders in the time period specified and shall increase or decrease its resources as needed to meet the specified completion times. CONTRACTOR also has the additional option of working on weekends and other nonbusiness days.

Work orders range in scope from a small asphalt patch to a large area (several thousand square feet) requiring backfill, concrete base, asphalt, replacement of sidewalks, driveways, grade and seed of adjacent areas, and sometimes other site-specific construction work. When not already in place, CONTRACTOR shall be required to provide traffic control in accordance with Section 02785.

Work Order Assignments:

CITY will provide CONTRACTOR with online access to its work order management system. A CITY inspector will pre-inspect and create a work order in Hansen for each site. The work order will include a list of work items and estimated quantities of each line item that needs to be completed based on the unit price schedule and a linked photograph of each site. The work order

will be assigned to CONTRACTOR with a scheduled start date as described in Section 00800 – Supplementary Conditions.

Completed Work:

CONTRACTOR shall close work orders in the Hansen system once the work is complete. A work order is not considered complete until CONTRACTOR has closed it out in Hansen.

CITY may perform a post-inspection on any Work Order to verify that the work has been completed. Work that is incomplete or does not meet the specifications will be returned to CONTRACTOR and will not be considered complete until the Work is corrected. Section 00800 describes performance requirements for completing work.

As soon as CONTRACTOR completes a work order and the repair area is safe, CONTRACTOR shall move any CITY owned traffic control or other safety devices out of the way and arrange for any 3rd party traffic control to be picked up so that traffic is no longer impeded. CONTRACTOR may not take possession of CITY owned traffic control or other CITY property.

Invoicing and Payment:

CONTRACTOR will be able to run reports in Hansen to show the completed work to date. This data may be exported to a spreadsheet. CONTRACTOR's invoice shall include a list of work orders completed along with the completion time for each work order. Each invoice shall include CONTRACTOR's calculations for performance incentives and/or liquidated damages.

Hansen Work Order Management System:

CITY will provide CONTRACTOR with online access to its work order management system (Hansen). CONTRACTOR can access the Hansen system via a virtual private network and compatible web browser. CONTRACTOR shall use the online system to receive new work, close completed Work Orders, update Work Order quantities if needed, upload site photographs, and for invoicing.

Site Photographs:

As part of the Work, CONTRACTOR shall take electronic post-construction photographs of each work site. The file name of each electronic photo shall include the corresponding address or work order number and the photo shall be uploaded to the Hansen system within two business days of when the work was completed.

Post-construction photos shall clearly show the area that was repaired after all work, including site cleanup, is complete. Site photos shall be a minimum 3 megapixel resolution, will be taken from a perspective that shows any remaining traffic control, and shall clearly display the address of the site within the picture and have a visible date stamp. Display of the address can be accomplished by including a whiteboard with the address written on it in the foreground of the picture or another method acceptable to CITY. If unexpected special conditions were encountered at a site before the restoration work was completed, CONTRACTOR shall send CITY additional photo(s) showing those special conditions.

Site cleanup:

CONTRACTOR shall clean each work site daily by removing any excess construction materials, trash or debris and shall sweep and remove any dirt, gravel, mud or other debris remaining on

asphalt, concrete, or other surfaces. Some work sites will already have minor dirt, gravel, mud or other debris from the line repair work that was performed by others. As part of this daily site cleanup, CONTRACTOR shall also remove any preexisting minor dirt, gravel, mud or other debris that may be present.

Work Sites Not Ready for Restoration:

If CONTRACTOR encounters a work site that cannot be restored due to work required by others or some other reason out of the control of CONTRACTOR, CONTRACTOR shall notify CITY via email of the reason the restoration Work cannot be performed, what action is required to allow the restoration Work to commence, and shall include a photograph of the work site clearly showing the reason the restoration Work cannot be performed.

Compensation for Wasted Trips:

Wasted trips by CITY or CONTRACTOR shall be compensated for as outlined in Section 01260 – Measurement and Payment.

COMMUNICATION AND COORDINATION

Field Manager:

CONTRACTOR shall designate a Field Manager, who shall be responsible for managing the Work on a day-to-day basis and see that all restorations are completed. The Field Manager shall be dedicated full-time for the duration of the Contract and shall be available on every business day. CONTRACTOR's Field Manager shall be equipped with a mobile phone and email device and a laptop with a mobile internet connection.

When the Field Manager is unavailable, CONTRACTOR shall dedicate a qualified substitute with the same mobile communication access who shall act in his behalf to ensure uninterrupted performance.

Coordination with CITY Staff and Other Contractors:

CONTRACTOR shall be required to coordinate Work with other parties who may be working at the site or may have equipment at the site to ensure an efficient and uninterrupted transition between parties. Other parties who may be working or have equipment at a Work Order site include Water Services or other CITY Departments, other Contractors, utility marking services, other utilities, the property owner, and/or traffic control device vendors.

Resident/citizen Communication:

If the work will impede access to a resident's property, CONTRACTOR shall notify the resident before starting work. Additionally, when requested by residents, CONTRACTOR shall provide alternate suitable access and parking. In all cases where CONTRACTOR performs work on private property, CONTRACTOR shall leave a door hanger including the following information on each affected residence or business:

- CONTRACTOR's name and phone number
- Brief summary of work to be performed by CONTRACTOR and that CONTRACTOR is working on behalf of the Water Services Department

- The door hanger shall instruct resident to contact CONTRACTOR directly for quality-of-work related complaints

The phone number provided by CONTRACTOR shall be answered between the hours of 8:00 am and 4:00 pm Monday through Friday. When the phone is not answered, customers will be able to leave a voicemail message. Voicemail messages shall be returned on the next work day at the latest.

CONTRACTOR shall notify CITY in writing each time they receive a customer complaint. This notification shall include the following information:

- Customer's name, address and contact information
- Date of initial complaint and the nature of the complaint
- Action to be taken to resolve complaint
- Target date for resolution of the complaint

RAPID RESPONSE (HIGH PRIORITY) WORK ORDERS:

If a Work Order is designated by CITY as "rapid response", it shall take priority over other Work. Rapid Response work will typically consist of concrete and paving so that the street can be reopened for traffic as quickly as possible. CONTRACTOR will be notified of rapid response work via email or phone in addition to an electronic Work Order as described above. The designation of certain Work Orders as rapid response shall be at the sole discretion of CITY. No more than 10% of work orders in any month will be designated as Rapid Response. See Section 00800 – Supplementary Conditions for performance requirements for rapid response work orders.

TIME TO COMPLETE WORK ORDERS:

When Work is issued pursuant to this agreement, CONTRACTOR shall complete the Work as required in Section 00800, Supplementary General Conditions.

End of Section

SECTION 01260 – Measurement and Payment

- A. General:** Payment for Work performed by the CONTRACTOR under these Contract Documents will be made in accordance with the General Conditions at the contract unit prices. Such payment shall compensate the Contractor for all labor, equipment, materials, tools, safety devices and traffic control, investigation, travel, coordination, saw cutting and other preparation work, cleanup, other incidental expenses, and all Work and risk necessary to complete the project.

Most job sites encountered by CONTRACTOR will have areas of street, driveway, yard, or sidewalk that are filled, partially or completely, with gravel and/or other material. CONTRACTOR shall include the cost of any required excavation of gravel and/or other material in CONTRACTOR'S unit prices. Many job sites will also be covered by steel plates. CONTRACTOR shall include the cost of moving steel plates in CONTRACTOR'S unit prices.

B. Measurement:

For each repair location, the CONTRACTOR will be assigned a work order noting the item number(s) and the estimated quantities. No work shall be given to the CONTRACTOR verbally. If the CONTRACTOR finds that additional work is needed that would increase the cost of the work order by more than 10%, CONTRACTOR shall request approval from CITY prior to beginning extra work. CONTRACTOR shall provide concrete and/or asphalt weigh tickets or other evidence if requested by CITY to substantiate invoice quantities.

C. Payment:

1. **Small Asphalt In-Place 1 (less than 200 SF):** Payment will be made at the contract bid unit price for Asphalt Surface In-Place 1 (average is between 150-100 SQFT) per each completed area and a thickness of 2 inches.
2. **Asphalt Surface In-Place 2 (200 – 1,700 SF):** Patches larger than 200 square feet shall be placed with a self-propelled mechanical paving machine. Payment will be made at the contract bid unit price for Asphalt Surface In-Place 2 (200 – 1,700 SF) per square feet of completed area and a thickness of 2 inches.
3. **Asphalt Surface In-Place 3 (>1,700 SF):** This is a repair where the area is greater than 1,700 square feet. Payment will be made at the contract bid unit price for Asphalt Surface In-Place 3 (>1,700 SF) per Ton of asphalt used.
4. **2" Mill and Asphalt Engineering for Water Main Replacements:** Payment for Mill and Asphalt for water main replacements shall be made at contract bid price for two (2) inches cold milling and asphalt surface in-place. Payment will include all costs including any street striping, traffic control or any other incidental costs. Typical area will be one lane wide but could be any length. Pavement that is milled may be either asphalt, concrete, or a combination of both.
5. Not Used
6. **Concrete Base In Place:** This item is for placement of concrete base prior to asphalt overlay and includes the use of high early-strength concrete where needed. This work includes any preparation needed such as saw cutting or removing excess fill to the

correct level. Payment will be made at the contract bid unit price for Concrete Base In Place per cubic yard of concrete placed. Unless otherwise directed by CITY, concrete base shall be 8" thick.

7. **Two (2) Inch Depth Cold Milling (>200 sqft):** Payment for cold milling shall be made at the contract bid unit price for two (2) inch depth cold milling per square foot of pavement milled. Contractor shall make sufficient passes or cuts to remove a minimum of two (2) inches over the entire section to be repaired. Pavement may be either asphalt, concrete, or a combination of both.
8. **Flowable Fill, placed:** This item is for the placement of digable flowable fill needed to make the repair. Payment for digable flowable fill shall be made at the contract bid unit price for flowable fill per cubic yard placed.
9. **Untreated Compacted Aggregate Backfill, placed:** Payment for Untreated Compacted Aggregate Backfill shall be made at the contract bid unit price for Untreated Compacted Aggregate Backfill per cubic yard placed.
10. **Water Valve Adjustment:** Payment for this item shall be made at the contract bid unit price for each Water Valve Adjustment made. Payment for water valve adjustment will only be made when the height of the valve has to be changed in order to make it level with the surrounding surface.
11. **Sewer Manhole Adjustment Ring:** Contractor shall furnish and install sewer manhole cover adjusting rings approved for use by CITY in accordance with Public Works Department Standards. Payment for this item shall be at the contract bid unit price for each Manhole Adjustment Ring installed.
12. **Adjustable Sewer Manhole Ring and Cover:** Contractor shall furnish the adjustable sewer manhole assemblies. The adjustable manhole assemblies shall be as approved by the CITY and shall be installed according to the manufacturer's recommendations and City standards. Payment for this item shall be at the contract bid unit price for each Adjustable Sewer Manhole Ring and Cover installed.
13. Not Used
14. **Portland Cement Concrete Curb:** Payment for Type CG-1 or CG-2 curbs will be at the contract bid unit price for Portland Cement Concrete Curb per linear foot installed. CONTRACTOR shall match existing curb.
15. **Rapid Response Priority Work Order:** When requested by CITY, CONTRACTOR shall complete the portion of work needed to reopen street within two business days. No more than 10% of work orders in any month will be designated as Rapid Response.
16. **Concrete Steps:** Payment for this item shall be made at the contract bid unit price for concrete steps per square foot installed. Unless other directed by CITY, concrete steps shall match adjacent or preexisting steps and CITY and OSHA standards.
17. **Brick/Stone Walk or Border:** Payment for this item shall be made at the contract bid unit price for Brick/Stone Walk or Border per square foot installed. Unless other directed

by CITY, brick and stonework shall match adjacent brick and stonework and CITY and OSHA standards.

- 18-19. **Portland Cement Concrete Sidewalks (Non-Reinforced):** Payment shall be made at the contract bid unit price for the applicable thickness of sidewalk per square foot installed.
20. **10" Concrete Street:** Payment shall be made at the contract bid unit price for concrete street per square foot installed per Section 2100.
- 21-22. **Portland Cement Concrete Driveways (Non-Reinforced):** Payment shall be made at the contract bid unit price for the applicable thickness of driveway per square foot installed.
23. **ADA Accessible Ramps With Detectable Warning:** Payment shall be made at the contract bid unit price for ADA Accessible Ramps With Detectable Warning per square foot installed. CONTRACTOR shall ensure that all ADA ramps meet current laws and will coordinate with other City Departments if necessary to ensure ramp compliance.
- 24-25. **Reinforced Portland Cement Concrete Sidewalks:** Payment shall be made at the bid contract unit price per square foot for the applicable thickness of sidewalk. CONTRACTOR shall replace steel reinforced sidewalks with reinforced sidewalks.
26. **Other Special Construction:** Scope and Payment for Other Special Construction shall be determined on a case-by-case basis for a lump sum at 5% above the CONTRACTOR's cost.
- 27-28. **Reinforced Portland Cement Concrete Driveways:** Payment shall be made at the bid contract unit price per square foot for the applicable thickness of driveway. CONTRACTOR shall replace steel reinforced driveways with reinforced driveways.
29. **Concrete Stamping and/or Coloring:** Payment shall be made at the contract bid unit price for Concrete Stamping and/or Coloring per square foot installed. This is additional payment for adding of coloring or concrete stamping to the cost of the applicable type of sidewalk or driveway.
30. **Fill Dirt, placed:** Payment for fill dirt shall be made at the contract bid unit price for fill dirt per cubic yard. Fill dirt quantities shall be rounded to the nearest cubic yard.
31. **Seeding:** Payment for Seeding shall be made at the Contract Bid Unit Price for Seeding per square foot. This does not include costs for topsoil as defined in item 33.
32. **Sodding:** Payment for Sodding shall be made at the Contract Bid Unit Price for Sodding per in-place square foot.
33. **Top Soil in Place One-inch Thick:** Payment for Top Soil in Place One-inch Thick shall be made at the Contract Bid Unit Price for Top Soil in Place One-inch Thick per one-inch layer per square foot in-place.

34. **Planting:** Scope and Payment for Planting shall be determined on a case-by-case basis for a lump sum at 5% above the CONTRACTOR's cost.
35. **Fencing:** Scope and Payment for Fencing shall be determined on a case-by-case basis for a lump sum at 5% above the CONTRACTOR's cost.
36. **Special Traffic Control Signage:** Payment for Special Traffic Control Signage shall be made at 5% above the CONTRACTOR's cost. This item shall apply to special situations where traffic control signage is needed beyond two blocks of the restoration site.
37. **Pavement Markings:** Payment for Pavement Markings shall be made at the Contract Bid Unit Price for Pavement Markings per linear foot. The pavement marking shall comply with the requirements of Public Works Department Standard Pavement Markings for thermoplastic material. If permanent markings cannot be installed before traffic control devices are removed, CONTRACTOR shall provide temporary markings at no additional cost. In all cases, permanent pavement markings shall be completed and invoiced in the same invoice period as the rest of the Work on the Workorder.
38. **Walls:** Scope and Payment for Walls shall be determined on a case-by-case basis for a lump sum at 5% above the CONTRACTOR's cost. Such payment and price shall constitute full compensation for any engineering, and for all work necessary to complete the item.
39. Not Used
40. **Small Cold Milling (<200 sqft):** Payment for two-inch depth concrete milling for areas less than 200 square feet shall be made at the Contract Bid Unit-Price for two-inch depth concrete milling typical will be 150-200 Sq Ft.. Pavement may be either asphalt, concrete, or a combination of both.
41. **Flush embedment of City-Provided Steel Plates:** Consists of milling road surface so that City-provided steel plate will sit flush with the surface. Any gap around edge of plate shall be 2" or less. Unit cost is per plate and includes moving of plate before and after milling.
42. **Monthly Administration Charge:** Lump sum monthly charge to account for costs associated with administration of the contract in addition to the unit price items above.
43. **Monthly Performance Add/Subtract:** Line item for monthly bonus or liquidated damages per Section 00800 – Supplementary Conditions.
44. **Unnecessary trip charge by Contractor:** Unit price payment will be made to Contractor per unnecessary field visit that was caused by City sending a work order to Contractor that was not ready for restoration. Examples include work orders where the site is still leaking, has exposed utilities that need to be repaired prior to restoration, or where a City crew is blocking access to the work site. This unit price payment shall be Contractor's

only remedy for unnecessary field visits. City will not pay Contractor for delays outside the City's control such as lack of access due to the property owner or another utility or contractor.

45. **Unnecessary trip charge by City Inspector:** This unit price will be deducted from Contractor's invoice for each unnecessary field trip by City Inspector that was caused by Contractor, for example when Contractor closes a work order but the work is not complete.

End of Section



APPLICATION FOR PAYMENT

Project Number _____

Project Title _____

Final Payment⁵

CONTRACTOR _____

Address _____

Application Number²: _____

Date: _____

Ordinance/Resolution Number: _____

Effective: _____

PO Number _____

Vendor Number _____

Application for Work Accomplished from _____ to _____

Original Contract Price	[1]		\$	-
Net by Change Orders through _____		[2]	\$	-
Current Contract Price (1+2)		[3]	\$	-
Completed Work	[4]	\$	-	
Disputed Amounts ³	[-]	[4a]	\$	-
Stored Material ⁴	[5]	\$	-	
Disputed Amounts ³	[-]	[5a]	\$	-
Total Completed and Stored to Date (4+5)		[6]	\$	-
Previous Payments	[7]	\$	-	
Previous Retainage	[8]	\$	-	
Total Previous Applications (7+8)		[9]	\$	-
Amount This Application (6-9)		[10]	\$	-
Less Retainage This Application (5%)		[-]	[11]	\$ -
Release of Retainage		[12]	\$	-
Total Due This Application (10-11+12)		[13]	\$	-
Liquidated Damages				
Completion of Work	[14]	\$	-	[-] \$ -
Prevailing Wage ⁷	[15]	\$	-	[-] \$ -
MBE/WBE Program ⁷	[16]	\$	-	[-] \$ -
Workforce Program ⁷	[17]	\$	-	[-] \$ -
Total Amount Due Contractor (13 - 14 through 17)		[18]	\$	-

Accompanying Documentation: ^{1, 2, 3, 4, 5, & 6} and any other information as necessary.

NOTE: Initial all figures on this Application and on the Schedule of Values that are changed to correct errors or conform to the amount recommended. Attach explanation of changes that have been made.

CONTRACTOR's Certification:

The undersigned CONTRACTOR certifies that (a) all previous progress payments received from OWNER on account of Work done under this Contract have been applied on account to discharge CONTRACTOR's legitimate obligations incurred in connection with Work covered by all prior Applications for Payment; (b) at time of payment, title of all Work, materials and equipment incorporated into said Work or otherwise listed in or covered by this Application for Payment will pass to OWNER free and clear of all Liens, security interests and encumbrances (except such as are covered by a Bond acceptable to OWNER indemnifying OWNER against any such Lien, security interest or encumbrance); and (c) all Work covered by this Application for Payment is in accordance with the Contract Documents and not defective; and (d) all manufactured goods or commodities used or supplied for this Project are in compliance with Kansas City's Buy America ordinance.

By _____
 Contractor Authorized Representative (Print) Signature

Date _____

State of _____)
 County of _____)SS

Subscribed and Sworn to before me this _____ day of _____.

My commission expires:

Notary Public: _____

DESIGN PROFESSIONAL's Recommendation of Payment:

In accordance with the Contract Documents, based on on-Site observations and the data comprising this application, the DESIGN PROFESSIONAL recommends to the OWNER that to the best of the DESIGN PROFESSIONAL's knowledge, information and belief the Work has progressed as indicated, the quality of the Work is in accordance with the Contract Documents, and the CONTRACTOR is entitled to payment of the Amount above listed in this application.

Name of firm (Print) DESIGN PROFESSIONAL (Print) (Signature)

Date: _____

Construction/Program Manager's Recommendation of Payment: (if applicable)

In accordance with the Contract Documents, based on on-Site observations and the data comprising this application, the Construction/Program Manager recommends to the OWNER that to the best of the Construction/Program Manager's knowledge, information and belief the Work has progressed as indicated, the quality of the Work is in accordance with the Contract Documents, and the CONTRACTOR is entitled to payment of the Amount above listed in this application.

Construction/Program Manager firm (Print) Authorized Representative (Print) (Signature)

Date: _____

City's Representative's Agreement with Recommendation of Payment

City's Representative(print) (Signature) (Date)

City's Approval

The amount previously recommended is approved for payment.

Director or Designee (Print) (Signature) (Date)

¹See General Conditions Article 14.02 A and B

²Proof of tax compliance if 1st payment and if Contract amount exceeds \$150,000.00

³Schedule of Values--Denote any amounts currently disputed in this application. Attach additional dispute documentation if required.

⁴If requesting payment for stored materials, see General Conditions Article 14.02 A.1

⁵If final payment, current proof of tax compliance if Contract is longer than 1 year and amount exceeds \$150,000.00.

⁶ Per General Conditions Sec. 14.02 attach a copy of the most recent 00485.01 M/WBE Monthly Utilization Report, 00485.02 Project Workforce Monthly Report and 00485.03 Company-Wide Workforce Monthly Report CONTRACTOR has submitted to the City's Human Relations Department

⁷Applicable only if final payment

REMINDER: CONTRACTOR is responsible for meeting or exceeding the the D/M/WBE participation amounts in its Contractor Utilization Plan (CUP) as amended by any previously approved Request for Modification/Substitution. Any Change Orders or amendments modifying the amount CONTRACTOR is to be compensated will have correspondingly impacted the amount of compensation due D/M/WBEs for purposes of meeting or exceeding the Bidder/Proposer participation. CONTRACTOR is again reminded to consider the effect of any Change Order or amendment, and to submit a Request for Modification/Substitution if appropriate.

Distribution: Owner Project Manager
 Contractor Design Professional
 Construction Manager _____



SCHEDULE OF VALUES

Project Number _____

Project Title _____

HRD APPROVED CUP		
MBE	WBE	DBE
\$0.00	\$0.00	\$0.00
%	%	%

A SPEC SECTION	B UNIT PRICE CONTRACTS			E DESCRIPTION OF WORK UNIT ITEM DESCRIPTION	F \$ UNIT PRICE	G NO. OF UNITS	H \$ TOTAL OR LUMP SUM	I UNITS COMPL ETE	J \$ COMPLETED WORK	K \$ STORED MATERIAL	L \$ TOTAL COMPLETED AND STORED TO DATE		M TOTALS TO DATE			O % AT BOTTO M	R \$ TOTAL PREVIOUS APPLICATIONS	S \$ AMOUNT THIS APPLICATION L-R	
	UNIT ITEM NO.	UNIT	ESTIMATED QUANTITY								N \$ J+K	P % J/H	N \$ MBE	O \$ WBE	P \$ DBE				
																	P/L		
																		O/L	
																		N/L	



SUBCONTRACTORS AND MAJOR MATERIAL SUPPLIERS LIST

Project Number _____ Project Title _____

From Contractor _____ To _____ Date _____

Spec. No.	Section Title	4	Firm, Address (Check box if Supplier)	Phone, FAX and e-mail	Contact

Attachments:

Signed by: _____ Date _____

Distribution: Owner Contractor Construction Manager Design Professional Consultant Other



DAILY LABOR FORCE REPORT

Project Number _____ Day _____ Date _____

Project Title _____

Contractor _____

Subcontractor _____

Weather: (Indicate if weather prevented work and why) _____

Shift: (circle) 5–8 hr Days 4–10 hr Days Other _____

* This report *MUST be completed and turned in* for EACH DAY until FINAL COMPLETION.

Worker's Full Legal Name	Occupational Title or Classification Group & Skill	Hours Worked & Time (i.e. 10AM – 4PM)	Race & Gender

I CERTIFY THAT ALL OF THE INFORMATION PROVIDED ABOVE IS TRUE AND COMPLETE.

Contractor/Subcontractor Representative:

Complete Name: (print) _____ Title: (print) _____

Signature: _____

Page ____ of ____

Distribution: City Department Contractor Subcontractor Other



CERTIFICATE OF SUBSTANTIAL COMPLETION

Project Number _____

Project Title _____

CONTRACT FOR: _____

CONTRACTOR: _____

DATE OF ISSUANCE: _____

PROJECT OR DESIGNATED PORTION SHALL INCLUDE:

The Work performed under this Contract has been reviewed and found, to the Design Professional's and/or Construction Manager's best knowledge, information and belief, to be substantially complete. Substantial Completion is the state in the progress of the Work when the Work or designated portion thereof is sufficiently complete in accordance with the Contract Documents so the Owner can occupy or utilize the Work for its intended use. The date of Substantial Completion of Project or portion thereof designated above is hereby established as _____ which is also the date of commencement of applicable warranties required by the Contract Documents, except as stated below:

A list of items to be completed or corrected is attached hereto. The failure to include any items on such list does not alter the responsibility of the Contractor to complete all Work in accordance with the Contract Documents.

CONSTRUCTION MANAGER BY _____ DATE _____

DESIGN PROFESSIONAL BY _____ DATE _____

The Contractor will complete or correct the Work on the list of items attached hereto within _____ days from the above date of Substantial Completion.

CONSTRUCTION MANAGER BY _____ DATE _____

DESIGN PROFESSIONAL BY _____ DATE _____

The Owner accepts the Work or designated portion thereof as substantially complete and will assume full possession thereof at _____ (time) on _____ (date).

OWNER'S REPRESENTATIVE BY _____ DATE _____

- Distribution:
- Owner
 - Contractor
 - Construction Manager
 - Design Professional
 - Consultant _____
 - Other _____

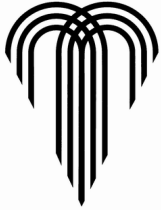

PUNCH LIST

Project Number _____

Project Title _____

CONTRACTOR _____

From _____ Site Visit Date _____

The following items require the attention of the CONTRACTOR for completion or correction. This list may not be all-inclusive, and the failure to include any items on this list does not alter the responsibility of the CONTRACTOR to complete all Work in accordance with the Contract Documents.

Item No.	Location (Area)	Description	Correction/ Completion Date	Verification Check
----------	-----------------	-------------	-----------------------------	--------------------

Attachments

Signed by: _____ Date: _____

DESIGN PROFESSIONAL (Firm/In House)

- Distribution:
- OWNER
 - CONTRACTOR
 - DESIGN PROFESSIONAL
 - Consultant _____
 - Other _____



CONTRACTOR AFFIDAVIT FOR FINAL PAYMENT

Project Number _____

Project Title _____

STATE OF _____)
)SS
COUNTY OF _____)

The Undersigned, _____ of lawful
(Name)

age, being first duly sworn, states under oath as follows:

1. I am the _____ of _____ who is the general
(Title) (CONTRACTOR)
CONTRACTOR for the CITY on Project No. _____ and Project Title _____.

2. All payrolls, material bills, use of equipment and other indebtedness connected with the Work for this Project have been paid and all Claims of whatever nature have been satisfied, as required by the Contract.

3 (✓) ___ Prevailing wage does not apply; or

(✓) ___ All provisions and requirements set forth in Chapter 290, Section 290.210 through and including 290.340, Missouri Revised Statutes, pertaining to the payment of wages to workmen employed on public works projects have been fully satisfied and there has been no exception to the full and complete compliance with these provisions and requirements and the Annual Wage Order contained in the Contract in carrying out the Contract and Work. CONTRACTOR has fully complied with the requirements of the prevailing wage law as required in the Contract and has attached affidavits from all Subcontractors on this Project, regardless of tier, affirming compliance with the prevailing wage law as stipulated in the Contract.

4. I hereby certify that (a) at project completion and pursuant to contractor's final request for payment, contractor achieved (____%) Minority Business Enterprise (MBE) participation and (____%) Women Business Enterprise (WBE) participation on this contract, and (b) listed herein are the names of all certified M/WBE subcontractors, regardless of tier, with whom I, or my subcontractors contracted.

1. Name of MBE/WBE Firm _____
Address _____

Telephone Number (_____) _____
IRS Number _____
Area/Scope*of Work _____
Subcontract Final Amount _____

2. Name of MBE/WBE Firm _____
Address _____

Telephone Number (_____) _____
IRS Number _____
Area/Scope*of Work _____
Subcontract Final Amount _____

List additional subcontractors, if any, on a similar form and attach to the bid.

Supplier** Final Amount: _____

*Reference to specification sections or bid item number.

- (✓) ___ Met or exceeded the Contract utilization goals; or
- (✓) ___ Failed to meet the Contract utilization goals (attach waiver, substitution or modification); or
- (✓) ___ No goals applied to this Project.

5. CONTRACTOR certifies that each Subcontractor has received full payment for its respective work in connection with the Contract.

6. If applicable, I hereby certify that (1) at project completion and pursuant to contractor's final request for payment, contractor achieved, company-wide, at least ten percent (10%) minority workforce participation and two percent (2%) women workforce participation and (2) a true and accurate copy of my final project workforce monthly report is attached. **NOTE: This paragraph is only applicable if you completed a construction contract that was estimated by the City, prior to solicitation, as requiring more than 800 construction labor hours and costing in excess of \$300,000.00. If applicable you MUST attach copies of your final monthly workforce reports.**

7. This affidavit is made in behalf of the CONTRACTOR for the purpose of securing from Kansas City, Missouri, the certification of completion of the Project and receiving payment therefore.

8. If the Contract amount exceeded \$150,000, CONTRACTOR has submitted proof of compliance with the City tax ordinances administered by the City's Commissioner of Revenue and has on file proof of tax compliance from all Subcontractors. If the Contract term exceeded one (1) year, CONTRACTOR has provided proof of compliance with the City tax ordinances administered by the City's Commissioner of Revenue prior to receiving final payment and has on file proof of tax compliance from all Subcontractors prior to the Subcontractor receiving final payment from CONTRACTOR.

CONTRACTOR _____

By _____
(Authorized Signature)

Title _____

On this _____ day of _____, _____, before me appeared _____, to me personally known to be the _____ of the _____,

and who executed the foregoing instrument and acknowledged that (s)he executed the same on behalf of _____ as its free act and deed.

IN WITNESS WHEREOF, I have hereunto set my hand and affixed my official seal on the day and year first above written.

My commission expires:

Notary Public



SUBCONTRACTOR AFFIDAVIT FOR FINAL PAYMENT

Project Number _____

Project Title _____

STATE OF MISSOURI)

) ss:

COUNTY OF _____)

After being duly sworn the person whose name and signature appears below hereby states under penalty of perjury that:

1. I am the duly authorized officer of the business indicated below (hereinafter Subcontractor) and I make this affidavit on behalf of Subcontractor in accordance with the requirements set forth in Section 290.290, RSMo. Subcontractor has completed all of the Work required under the terms and conditions of a subcontract as follows:

Subcontract with: _____, Contractor

Work Performed: _____

Total Dollar Amount of Subcontract and all Change Orders: \$ _____

City Certified MBE WBE DBE NA
List certifications:

2. Subcontractor fully complied with the provisions and requirements of the Missouri Prevailing Wage Law set forth in Sections 290.210, RSMo through 290.340, RSMo.

Business Entity Type:

- Missouri Corporation
- Foreign Corporation
- Fictitious Name Corporation
- Sole Proprietor
- Limited Liability Company
- Partnership
- Joint Venture
- Other (Specify)

Subcontractor's Legal Name and Address

 Phone No. _____
 Fax: _____
 E:mail: _____
 Federal ID No. _____

I hereby certify that I have the authority to execute this affidavit on behalf of Subcontractor.

By: _____
 (Signature)

 (Title)

_____ (Print Name)
 _____ (Date)

NOTARY

Subscribed and sworn to before me this ____ day of _____, 20____.

My Commission Expires: _____ By _____

Print Name

Title



DAILY FIELD OBSERVATION REPORT

Project Number _____

Project Title _____

Contractor _____

Report Number _____ Date _____ Time _____

Weather

- Clear
- Overcast
- Rain
- Snow
- Foggy
- Cold

- Warm
- Hot
- Temperature Range _____

Site Conditions

- Clear
- Muddy
- Dusty
- _____

Day

- Monday
- Tuesday
- Wednesday
- Thursday
- Friday
- _____

Persons Contacted:

Work Observed:

Items Discussed:

Materials Delivered:

Requested Revisions or Interpretations:

Nonconforming Work Reported This Date To Contractor:

Remarks:

Attachments

Signed by: _____

Date: _____

- Distribution:
- Owner
 - Contractor
 - Construction Manager
 - Design Professional
 - Consultant _____
 - Other _____



PERIODIC FIELD OBSERVATION REPORT

Project Number _____

Project Title _____

Contractor _____

Report Number _____ Date _____ Time _____

Weather

- Clear Snow
 Overcast Foggy
 Rain Cold

- Warm
 Hot
 Temperature Range _____

Site Conditions

- Clear Dusty
 Muddy _____
 Temperature Range _____

Day

- Monday Thursday
 Tuesday Friday
 Wednesday _____

Persons Contacted:

Work Observed:

Items Discussed:

Remarks:

Attachments

Signed by: _____

Date: _____

- Distribution: Owner
 Contractor
 Construction Manager
 Design Professional
 Consultant _____
 Other _____



WEEKLY REPORT OF WORKING DAYS

Project Number _____

Project Title _____

Contractor _____

Report Number _____ Week Ending: _____

DATE:	WORKING DAY	REMARKS		
TOTAL THIS WEEK	PREVIOUSLY	TOTAL TO DATE	WORKING DAYS IN CONTRACT	REMAINING OR OVERTIME

Signed by OWNER'S REPRESENTATIVE _____ Date: _____

Signed by CONTRACTOR _____ Date: _____

Distribution: OWNER CONTRACTOR Construction Manager Design Professional Consultant Other

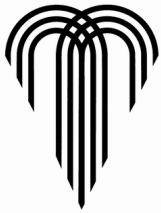

TRANSMITTAL LETTER

Project Number _____

Project Title _____

TO: _____ Date _____
 _____ Re: _____

 ATTN: _____

We are sending you Attached Under separate cover via _____ the following items:
 Shop Drawings Prints Drawings Samples Specifications
 Copy of Letter Change Order _____

Copies	Date	No.	Description

These are transmitted as checked below:

For Approval Approved as Submitted Resubmit _____ Copies for Approval
 For Your Use Approved as Noted Submit _____ Copies for Distribution
 As Requested Returned for Corrections Return _____ Corrected Prints
 For Review and Comment _____

Remarks: _____

By: _____

- Distribution:
- Owner
 - Contractor
 - Construction Manager
 - Design Professional
 - Consultant
 - Other



SUBSTITUTION REQUEST

Project Number _____

Project Title _____

To: _____

Authorization Number: _____

Re: _____

From: _____

Date: _____

Contract For: _____

Specification Title: _____

Section: _____ Page: _____ Article/Paragraph: _____

Proposed Substitution: _____

Manufacturer: _____ Address: _____ Phone No. _____

Trade Name: _____ Model No. _____

Installer: _____ Address: _____ Phone No. _____

History: New Product 2-5 years old 5-10 years old More than 10 years old

Differences between proposed substitution and specified product: _____

Point-by-point comparative data attached – REQUIRED

Undersigned certifies:

- Proposed substitution has been fully investigated and determined to be equal or superior in all respects to specified product.
- Same warranty will be furnished for proposed substitution as for specified product.
- Same maintenance, service, and availability of replacement parts, as applicable, are available.
- Proposed substitution will not affect or delay Progress Schedule, except as stated below.
- Cost data as stated above is complete. Claims for additional costs related to accepted substitution which may subsequently become apparent are to be waived.
- Proposed substitution does not affect dimensions and functional clearances, except as stated below.
- Payment will be made for changes to building design, including architectural or engineering design, detailing, licenses, royalties, and construction costs caused by the requested substitution.
- Coordination, installation, and changes in the Work as necessary for accepted substitution will be completed in all respects.

Reason for not providing specified item: _____

Similar Installation:

Project: _____

Design Professional: _____

Address: _____

Owner: _____

Date Installed: _____

Proposed substitution affects other parts of Work: No Yes; explain _____

Savings to Owner for accepting substitution: _____

Proposed substitution changes Contract Time: No Yes; add/deduct _____ days.

Supporting Data Attached:

Product Data Drawings Tests Reports Samples _____

Attachments: _____

Submitted by: _____

Signature: _____

Firm: _____

Address: _____

Telephone: _____ Fax: _____ E-Mail: _____

Additional Comments: Contractor Subcontractor Supplier Manufacturer DP _____

DESIGN PROFESSIONAL'S REVIEW AND ACTION

- Substitution approved – Make submittals in accordance with Specification Section 01300.
- Substitution approved as noted – Make submittals in accordance with Specification Section 01300.
- Substitution rejected – Use specified materials.
- Substitution Request received too late – Use specified materials.

Signed by: _____ Date: _____

-
- Distribution:
- Owner
 - Design Professional
 - Contractor
 - Consultant
 - Construction Manager
 - Other

STATE OF MISSOURI



John R. Ashcroft
Secretary of State

CORPORATION DIVISION
CERTIFICATE OF GOOD STANDING

I, JOHN R. ASHCROFT, Secretary of State of the STATE OF MISSOURI, do hereby certify that the records in my office and in my care and custody reveal that

SUPERIOR BOWEN ASPHALT COMPANY, L.L.C.
LC0031034

was created under the laws of this State on the 2nd day of September, 1999, and is active, having fully complied with all requirements of this office.

IN TESTIMONY WHEREOF, I hereunto set my hand and cause to be affixed the GREAT SEAL of the State of Missouri. Done at the City of Jefferson, this 18th day of January, 2023.

Secretary of State

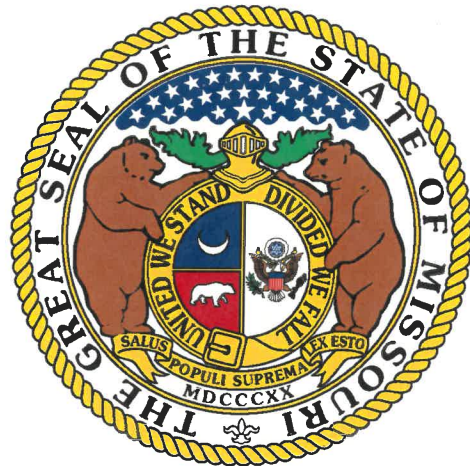

Certification Number: CERT-01182023-0140

SECTION 02070 – Fill Dirt and Top Soil

A. Codes and Standards:

- a. The publication listed below forms a part of this specification to the extent referenced. The publications are referred to within the text by the basic designation only.
- b. American Society for Testing and Materials (ASTM):
D 4318 - Test Method for Liquid Limit, Plastic Limit, and Plasticity Index of Soils

B. Summary: Areas to be seeded or sodded may require additional fill material to bring them up to grade or provide a suitable growing environment. This fill material will be either top soil only or a combination of topsoil and fill dirt. If the fill required is 6” or less, only topsoil will be used. If more than 6” of fill is needed, only the top 2” shall be topsoil with the remainder being fill dirt.

C. Material:

a. Fill Dirt:

- i. Suitable Material- Material suitable for use backfill, fill, and embankment include job excavated or borrow material that is free of debris, roots, organic matter, frozen matter and shale particles/rock/stone or gravel with all dimension less than 2 inches:
 1. Cohesion-less materials include gravels, gravel-sand mixtures, sands, gravelly sands; generally exclusive of clayey and silty material with the following properties:
 - a. Free-draining.
 - b. Impact compaction will not produce a well-defined moisture-density relationship curve.
 - c. Maximum density by impact methods will generally be less than by vibratory methods.
 - d. Generally less than 15% by dry weight of soil particles pass a No. 200 sieve
 2. Cohesive Materials include materials made up predominately of silts and clays generally exclusive of sands and gravel with the following properties:
 - a. Impact compaction will produce a well-defined moisture-density relationship curve.
 - b. Are not free draining.
- ii. Unsuitable Materials – Materials unsuitable for use in backfill, fill and embankment include all material that contains debris, roots, organic matter, frozen matter, shale particles/rock/stone or gravel with any dimension greater than 2 inches. Additionally, as determined by the City/Design Professional, any other materials that are too wet or

otherwise unsuitable for providing a stable subgrade or stable foundation for structures or trenches.

iii. Material used for embankment or fill:

1. For soils used below structural elements (such as: footings, slabs, pavements and mats), the portion of material passing the No. 40 sieve shall have a liquid limit not exceeding 40 and a plasticity index not exceeding 25 when tested in accordance with ASTM D4318.

b. **Top Soil:**

- i. On-Site Topsoil – Surface soil stripped and stockpiled on site and modified as necessary to meet the requirements specified herein. When available, topsoil must be existing surface soil stripped and stockpiled on the Site.
- ii. Off-Site Topsoil – Conform to requirements specified herein. Additional topsoil must be furnished by the Contractor.
- iii. Composition – Natural, friable soil representative of productive, well-drained soils in the area, free of subsoil, stumps, rocks larger than 1- inch diameter, brush, weeds, toxic substances and other material detrimental to plant growth. Amend topsoil pH range to obtain a pH of 5.5 to 7.
- iv. Topsoil shall be of a quality at least equal to the existing topsoil in adjacent areas, free from trash, stones, debris and well suited to support plant growth.

- c. **Samples:** Contractor shall submit samples of both fill dirt and top soil along with certified test reports for approval by CITY at the beginning of the contract. CONTRACTOR shall resubmit samples and test reports if CONTRACTOR plans to change material suppliers or products or when requested by CITY.

D. Execution:

- a. Construct and maintain erosion and sediment control practices and measures in accordance with CITY codes.
- b. Existing excavated material onsite can be reused if it meets these specifications.
- c. Any excavation work needed to complete fill dirt or top soil work shall be included in CONTRACTOR's unit prices.
- d. Excess non-suitable excavated materials shall be disposed of by CONTRACTOR at CONTRACTOR's expense.
- e. If CONTRACTOR damages areas adjacent to original repair while performing the WORK, CONTRACTOR shall repair those damaged areas at CONTRACTOR's expense.

- f. **Fill Dirt:** Place fill dirt in layers not to exceed 6 inches, and compact each layer as required to reduce erosion, slippage, settlement, or other related problems. Subsequent noticeable settlement due to improper material or execution shall be corrected at the CONTRACTOR's expense.

 - g. **Top Soil:** Scarify areas to receive top soiled to a minimum depth of 2 inches before placing topsoil. Final surfaces shall match adjacent existing areas, be non-ponding with a minimum 1% slope to drain, and be raked so that they are both smooth and even.
- D. Payment:** Payment shall be made at the Contract Unit Price as listed in Section 00412 – Unit Prices and as stated in Section 01260 Measurement and Payment. Such payment and price shall constitute full compensation for all labor, materials, testing, and equipment necessary to complete the item.

End of Section

GENERAL NOTES – All work shall conform to the latest APWA Standard Specifications and Design Criteria, Division II, and Kansas City, Missouri Supplements, Standards and Utility Cut regulations. Excavations shall be protected at all times. Once excavation is made, work shall continue on a workday basis until final restoration is complete. Cuts in roadways shall be plated or temporarily filled and capped with cold mix asphalt when work is not being performed. Trees shall be protected from damage both above and below ground. City Forester at 513-9550 must be contacted when digging within five (5) feet of a tree or when any damage to the tree or a root over three (3) inches occurs.

1. EXCAVATIONS – The top dimension of the excavation shall be equal to or greater than the bottom dimension. (All sides of the excavation shall be vertical or lay back greater than vertical before beginning backfill.)

BELL HOLE EXCAVATIONS – Excavation around underground facilities wider than surface opening will be allowed if the excavation is backfilled within 24 hours with flowable backfill as stated in 3 below. If unable to complete in the time frame, then the unsupported subgrade and pavement shall be removed to meet the provisions of section 1 above.

2. BEDDING – Utility bedding shall be granular bedding meeting 2102.12, compacted embankment meeting 2102.12, or flowable fill meeting 2102.12 unless approved by City. Bedding may extend no greater than 12" above utility. In the downtown loop granular bedding shall not be used.

3. BACKFILL – Backfill shall not be placed in water or mud. Clean graded rock or frozen material shall not be used as backfill. Backfill material and placement shall meet flowable fill meeting 2102.12 or untreated compacted aggregate meeting 2202. Utilities using untreated compacted aggregate will need to provide all compaction prior to completion of the permit.

4. ROADWAY SURFACES – Surfacing shall be of same type of materials as the existing surface. The finished surface shall be flush with the surrounding surface and shall match the slope and contours of the surrounding pavement.

A. Portland Cement Concrete – (Detail 4)

If the street cut is in a concrete street, the patch shall extend to the nearest joint in all directions. The patch shall be saw cut and all load transfer devices, expansion joints and reinforcing steel placed prior to placing the new concrete. Concrete shall be placed to the current thickness of pavement or ten (10) inches, whichever is thicker. The concrete must match the color and pattern of the previous pavement.

B. Asphalt – (DETAIL 1)

Pavement shall be removed twelve (12) inches beyond the edge of the disturbed subgrade or pavement, whichever is greater. Pavement shall be milled 2" deep and resurfaced for full width of the lane that is cut and minimum of 10 feet in length. Tack coat shall be applied (Section 2204), surface placed compacted (Section 2205.3) and joints sealed (Section 2206.2). If asphalt is not available at the time repairs are made, concrete may be brought to the surface as a temporary repair. Once asphalt is available, the mill and resurfacing shall be completed. Overlay a full lane for a block if more than 20% of the block is patches from active project or 50% of cumulation of all patches in a full lane for a block.

C. Other Materials

- Brick and other paver type materials shall be replaced with matching materials placed over eight (8) inch concrete base similar to DETAIL 1.
- Oiled crushed rock roads shall have four (4) inches of Type 3 asphaltic concrete placed over a minimum of six (6) inches of untreated compacted aggregate base.
- Earth or crushed rock roads shall have a minimum of twelve (12) inches of untreated compacted aggregate.
- All others shall be replaced as directed by the City.

5. OTHER SURFACES (Backfill under all surfaces shall be as shown in details for pavement.)

A. Sidewalks, Curbs and Driveways – Any section that is cut shall be removed to the nearest joint (Section 2209.3A and 2301.3A). Restoration shall match the existing surface material and joint pattern and shall comply with the appropriate standards.

B. Grass Areas – Finish to grade with six (6) inch topsoil compacted to 90%. Seed or sod (Section 2400) area as appropriate.

C. All Other Areas – Replace as directed by the City.

6. MISCELLANEOUS REGULATIONS

A. Permits are required before working in right-of-way, which must be on site during work.

1. Excavation Permits: Public Works 513-2670
Park Dept. (513-7606)
2. Traffic Control Permit: 513-2670

B. Notifications required before actual excavation begins:

1. 2 Working Day Minimum: MO. ONE CALL 1-800-344-7483.
2. 24-Hour Minimum: Public Works 513-4701.

C. Permit holder must have inspection of backfill or permit will be void. Contact utility cut inspection section @ 513-4701, fax 513-4717, to request inspection in advance.

D. Repairs shall match existing street slope and grade, and shall be maintained for three (3) years or bond period .

E. Any Pavement Markings removed by the repairs must be replaced with like materials.

F. All excavations (under traffic) must be embedded street plates unless the excavation is in safety secured and permitted site or within a lane closure (not under traffic).

G. All excavations that are made under emergency conditions when certified testing and CLSM are not available shall be considered at temporary repairs and the materials placed under such conditions shall be removed and replaced with CLSM or materials places and tested to meet compaction requirements. The removal and replacement shall be completed within 5 business days of completion of the original emergency repair.

H. Patch is defined as less than lanes width or less than 10 foot in length.

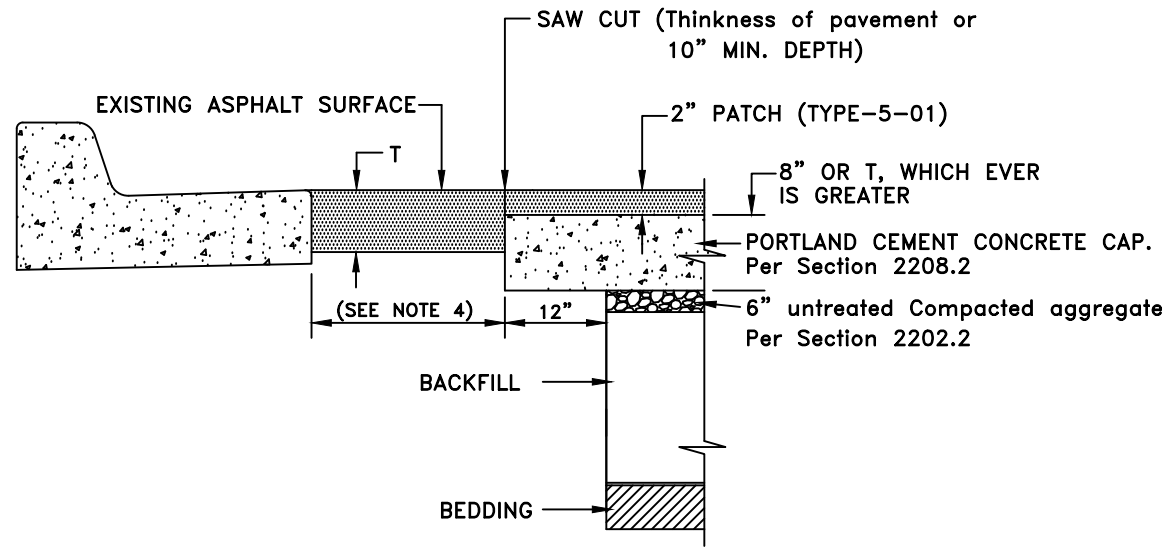

DETAIL 1 – ASPHALT PAVEMENT SURFACE

TYPICAL SECTION
NO SCALE



1-800-DIG-RITE or 811
(1-800-344-7483)
www.mo1call.com



Kansas City, Missouri
Public Works Department
Engineering Division

STREET CUT
RESTORATION

STANDARD DRAWING
NUMBER

SR-1
(PG 1 of 3)

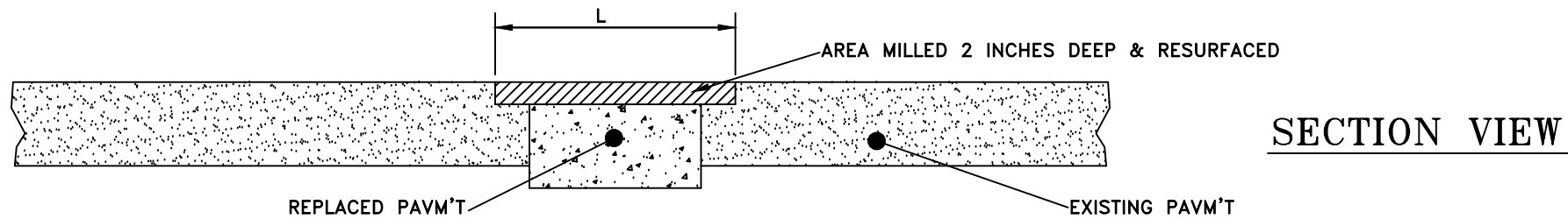
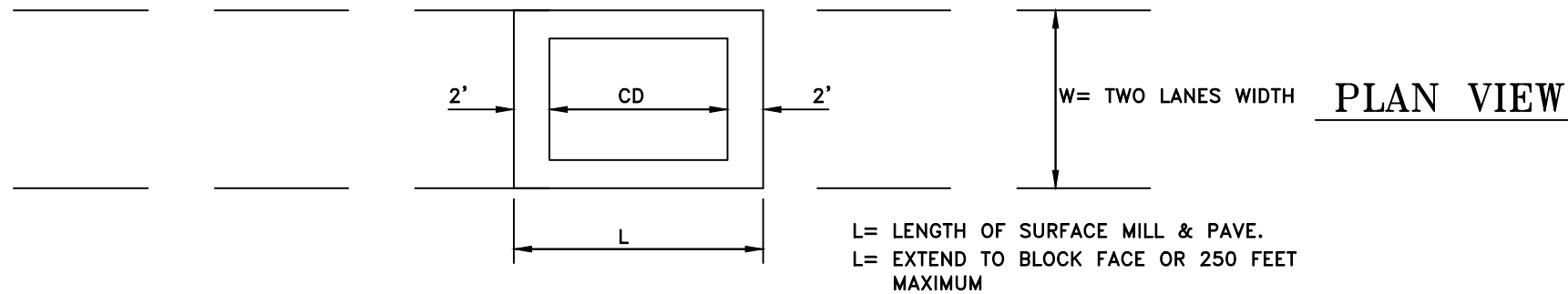

DETAIL 2

NO SCALE

E. In asphalt streets, core hole excavations 18 inches in diameter or less may be repaired after proper backfilling, by reinstalling the original surface core. The core must be fully intact and installed with an approved epoxy grout. The finished patch must have all cut lines completely filled with the grout.

7. EXCAVATING IN STREET PAVEMENTS WITHIN FIVE YEARS OF CONSTRUCTION OR RESURFACING.

The City will make available its proposed 2-year schedule of street construction and resurfacing to businesses that may require making street cuts. If a street cut is made, within 5 years after a street is constructed or resurfaced, the following requirements will apply: The Public Works Director may waive this requirement based on an emergency as defined by the Director of Public Works.

A. Asphalted Surfaced Streets

1. The width and length of the surfaced area shall be as follows:
WIDTH – two lane widths (parking lanes and bicycle lanes are considered part of the adjacent vehicle travel lane width and not separate lanes).

LENGTH – extend to block face or 250 feet maximum.

The area described above shall be milled to a depth of 2 inches and a two-inch thick asphalt surface course shall be placed. This is shown in Detail 2. All lanes affected by the cut shall be milled and resurfaced as stated above.

B. For Concrete Streets

The entire slab shall be removed and replaced to the existing joints.

8. In asphalt streets, when multiple street cuts are separated by less than 10 feet, the lane shall be resurfaced with a single, continuous and continuous patch.

9. EXCAVATING IN PAVED AREA ADJACENT TO A MANHOLE: If pavement is removed adjacent to a casting with a clear opening of 30 inches or less and it does not match the slope and grade of the surrounding pavement, the manhole ring must be replaced with an adjustable manhole ring. All adjustable manhole rings must be adjustable to meet the slope and grade of the pavement from 0 to 17%, and shall be able to be raised and lowered in 1/4 inch increments up to 2 3/4 inches. The ring and lid shall be rated for H20 traffic. Any casting with a diameter larger than 30 inches must be approved by the Director of Public Works prior to being installed. These casting requirements do not apply to valve castings.

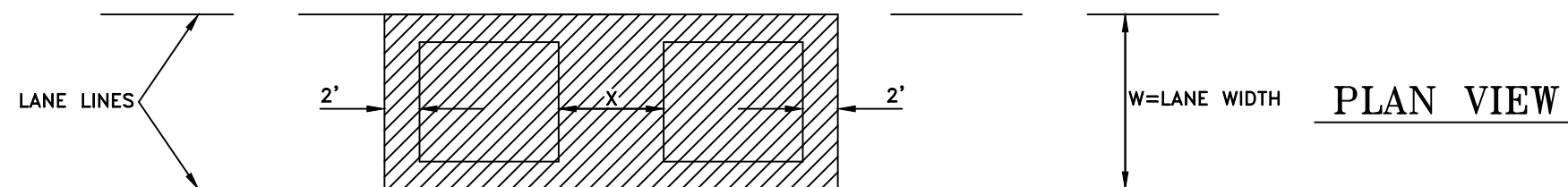

IF DISTANCE X IS LESS THAN W, THEN ENTIRE AREA SHADED WILL BE MILLED & RESURFACED.

DETAIL 3

NO SCALE



1-800-DIG-RITE or 811
(1-800-344-7483)
www.mo1call.com



Kansas City, Missouri
Public Works Department
Engineering Division

STREET CUT
RESTORATION

STANDARD DRAWING
NUMBER

SR-1

(PG 2 of 3)

Revised Sept. 2021

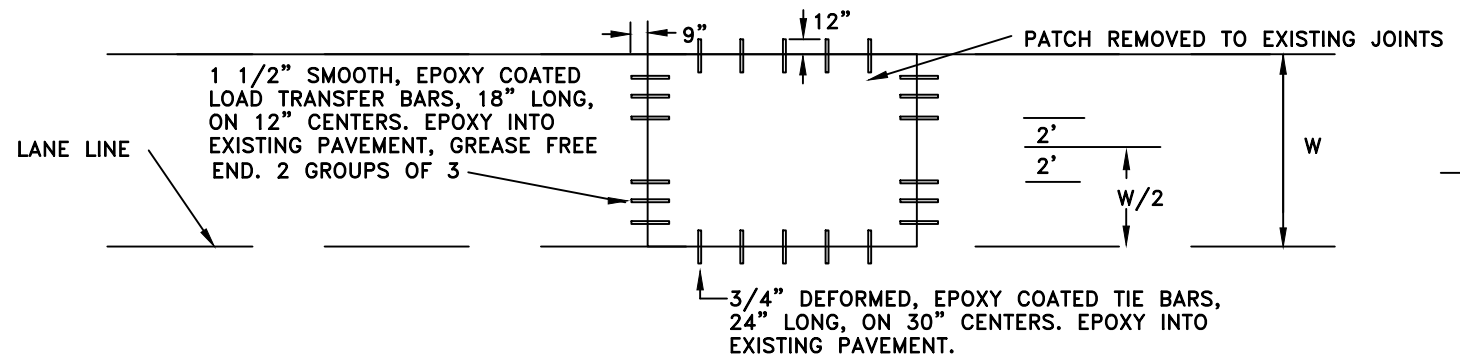

PLAN VIEW

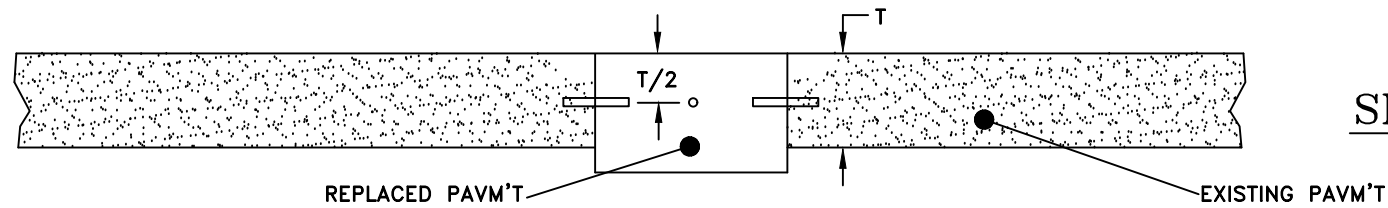

SECTION VIEW

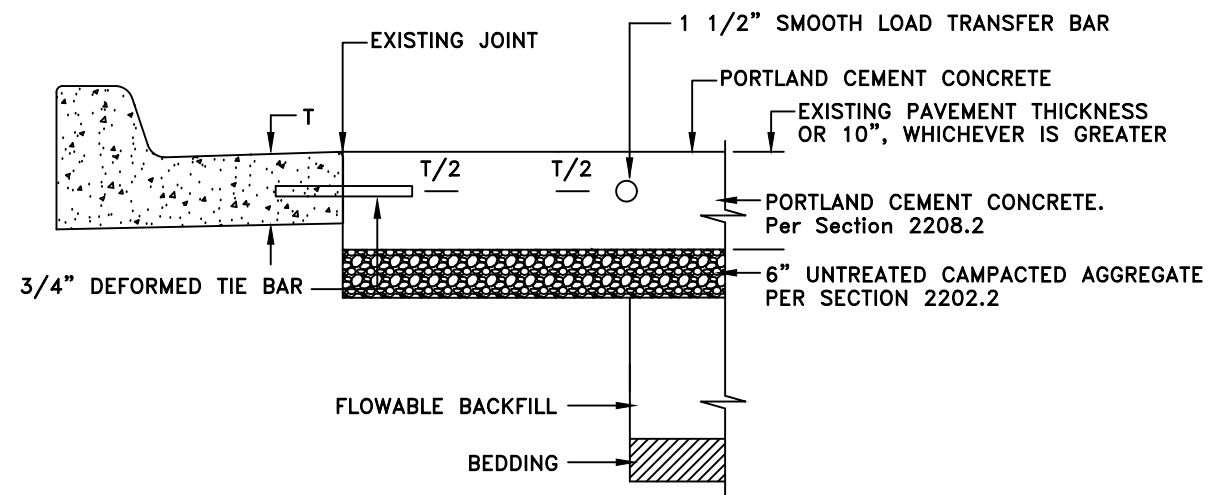

P.C. CONCRETE PAVEMENT SURFACE

DETAIL 4

NO SCALE

10. UTILITY APPURTENANCE SLOPE AND GRADE: All utility appurtenances shall be installed and maintained at a slope and grade that meets the surrounding pavement within 1/4 inch. The slope and grade tolerance shall be measured by placing a 6 foot straightedge across the manhole and measuring the distance between it and the pavement. One end of the straightedge shall be placed on the casting ring and the straightedge shall cross the opposite edge of the ring. This measurement shall be made on both sides in the direction of travel. All appurtenances shall be adjusted to the proper slope and grade prior to any street paving or patching. If adjustments are not completed prior to the street paving or patching, note 7 of this standard shall be applicable.

10. CRACK & JOINT SEALER: All perimeter joints will be sealed with 48 hours after finished concrete pavement surface.



1-800-DIG-RITE or 811
(1-800-344-7483)
www.mo1call.com



Kansas City, Missouri
Public Works Department
Engineering Division

STREET CUT
RESTORATION

STANDARD DRAWING
NUMBER

SR-1

(PG 3 of 3)

Revised Sept. 2021

SECTION 02130 - COLD MILLING

- A. Description:** This item shall consist of cold milling the existing street surface with equipment which shall mill or shave the surface irregularities out of the existing pavements to produce a smooth surface and, in most cases, to cut the pavement down to a two (2) inch depth.
- B. Cleanup:** Before and after milling, the CONTRACTOR shall clean all dirt, trash, and debris from the street. This material shall not be mixed with the milled material. An operator – driven motorized pickup sweeper shall be used unless otherwise approved by CITY. CONTRACTOR shall ensure that no debris is allowed to enter any stormdrain.

After the street has been milled, all loose asphalt, concrete and debris shall be swept and removed by CONTRACTOR. The CONTRACTOR shall also remove all milling debris from the street, curb, gutter and other surrounding areas.

- C. Disposal:** CONTRACTOR shall dispose of all materials removed from the site in a location meeting all CITY, State, and Federal regulations.

D. Details:

1. All passes with cold milling machine shall be parallel to the curb and as shown on the diagram on page 2 of this specification.
2. The furnished texture of the pavement shall be smooth and uniform.
3. The groove depths shall not exceed $\frac{1}{4}$ inch and the groove spacing shall not exceed 1 inch.
4. Cold milling at intersections shall be cut as detailed below:
5. Sufficient passes, or cuts, shall be made in order to remove a minimum of two (2) inches over the entire street section.

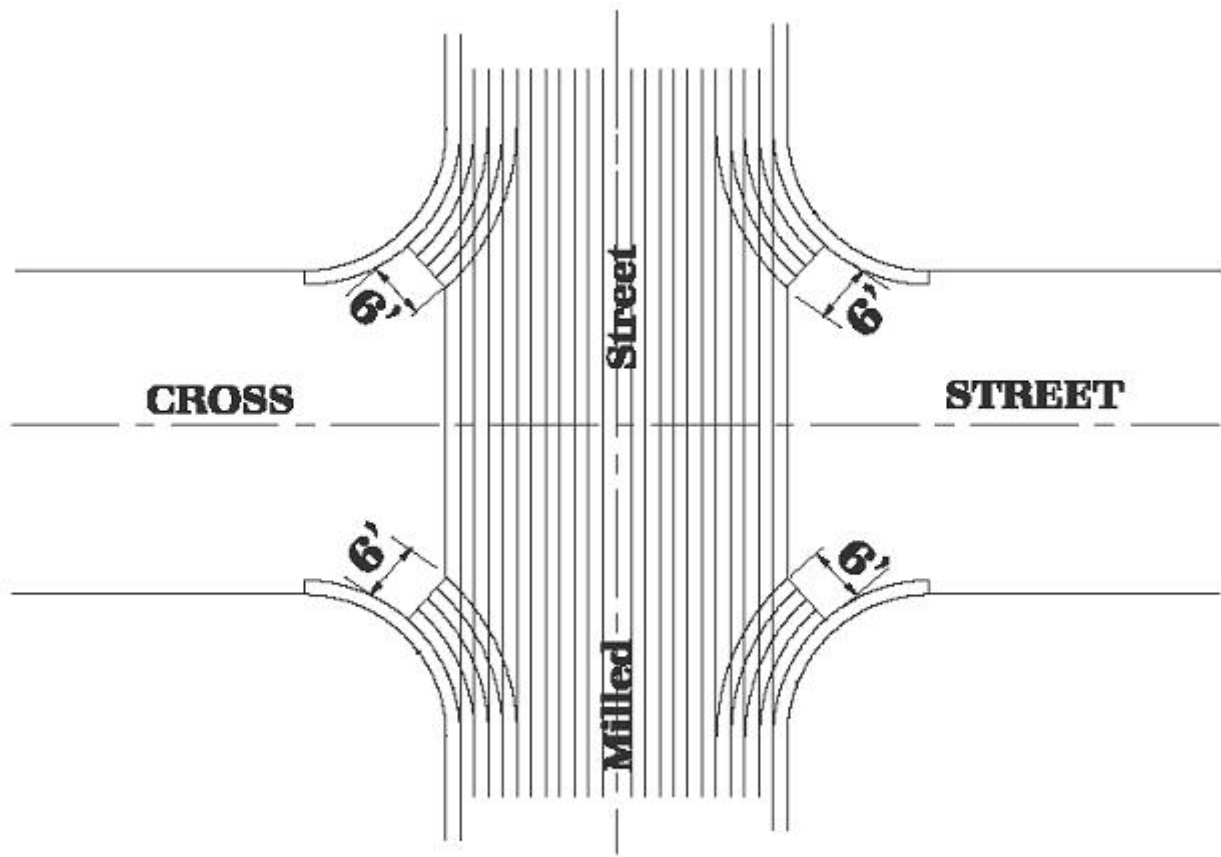

E. Measurement:

1. Asphalt pavement milling performed and provided by these specifications shall be measured by the square foot at the completion of work at each location. The Project Engineer and Job Superintendent will perform all measurements and will agree to the area of work satisfactorily performed at the end of each day.
2. The City will require no weight tickets on the material retained by the CONTRACTOR. The City makes no guarantee of the tonnage of cold milled material generated.
3. No separate payment will be made for measuring and weighing vehicles. All costs pertaining to this work shall be included in other bid items.

E. Payment: Payment for cold milling shall be made at the price bid per square foot of pavement milled per Section 00412 – Unit Prices and Section 01260 – Measurement and Payment.

End of Section

SECTION 2202 – UNTREATED COMPACTED AGGREGATE

- A. Referenced Standards:** The following standards are referenced directly in this section. The latest version of these standards shall be used.

ASTM

C 88 - Test Method for Soundness of Aggregates by Use of Sodium Sulfate or Magnesium Sulfate

C 131 - Test Method for Resistance to Degradation of Small-Size Coarse Aggregate by Abrasion and Impact in the Los Angeles Machine

C 136 - Test Method for Sieve Analysis of Fine and Course Aggregates

C 142 - Test Method for Clay Lumps and Friable Particles in Aggregates

D 4318 - Test Method for Liquid Limit, Plastic Limit, and Plasticity Index of Soils

AASHTO

T 99 - The Moisture-Density Relations of Soils Using a 5.5-lb. (2.5 kg) Rammer and a 12-in. (305 mm) Drop

- B. Summary:** Untreated Compacted Aggregate shall be placed where specified. Section 00412 – Unit Prices includes an estimated amount of "Untreated Compacted Aggregate". The actual amount may be greater, less, or none at all. All materials and placement shall be tested as outlined in the "Public Works Department Materials Testing Requirements". 2202.2

- B. Material:** The base course material shall consist of crushed stone aggregate with not more than 1.0% clay lumps and friable particles in accordance with ASTM C 142, and free from vegetable or other deleterious substances. The abrasion loss shall be no more than 35% when tested in accordance with ASTM C 131. That fraction passing the 1 inch (25.0 mm) sieve and retained on the No. 4 (4.75 mm) sieve shall have a loss not greater than 15% by weighted average at 5 cycles of ASTM C 88 (Magnesium Sulfate) Soundness Test. That fraction of the material passing the 1-inch (25.0 mm) Sieve and retained on the No. 4 (4.75 mm) Sieve shall contain less than 20% by weight of flat and elongated particles (flat being a ratio of 1 to 3 between thickness and least width and a ratio of 1 to 3 between the least width and length). The material shall consist of angular particles with no less than 90% of particle count having two or more fractured surfaces. The gradation in percentages by weight passing square mesh sieves shall be in accordance with ASTM C 136 and as follows:

<u>U. S. Standard</u> <u>Square Mesh Sieve</u>	<u>Percent Passing</u>
1-1/4" (31.5 mm)	100
1" (25.0 mm)	72-100
3/4" (19.0 mm)	60-90

3/8" (9.5 mm)	43-74
No. 4 (4.75 mm)	28-60
No. 10 (2.00 mm)	16-40
No. 40 (425 um)	3-22
No. 200 (75 um)	0-15

In addition to the above limits, the difference between the "Percent Passing Square Mesh Sieve" of successive sieve sizes shall not exceed 25 percent. That fraction of the material 2202.2 2202.4 22-5 passing the No. 40 (425 um) sieve shall have a plasticity index not to exceed 8 when tested in accordance with ASTM D 4318.

C. Placement:

- a. Subgrade: Prior to placement of base course material the previously prepared subgrade surface shall be cleared of all foreign substances and restored in shape, tolerance and density as specified in Section 2201 entitled "Subgrade Preparation".
- b. Material Placement: The material shall be uniformly spread in successive layers to such depth that when compacted, the base will have the minimum thickness specified. The contractor may construct the base in any number of layers that he chooses except that in no case shall any individual layer have a compacted thickness of more than 4 inches (10.16 cm). Each layer shall be compacted as hereinafter specified before any succeeding layer is placed. After spreading a layer of material, water in an amount sufficient to insure the desired compaction shall be added and uniformly mixed with the aggregate in a manner to prevent segregation. Excess moisture resulting in runoff shall be avoided. If for any reason, the material and subgrade become too wet to permit satisfactory work, they shall be allowed to dry to a moisture content that will permit satisfactory work.
- c. The material shall meet the required specifications immediately before compaction operations are commenced. If, for any reason, segregation occurs in excess of 10% variation from the gradation required under the above paragraph "Material" or the materials become contaminated, such segregated or contaminated materials shall be removed and replaced with suitable materials at the expense of the Contractor. The limited segregation of 10% variation will be ascertained by a sieve analysis of a minimum 100 pound (45.36 Kg) sample taken from the in-place base course. However, when crushed stone is used, segregated surface areas may be corrected by adding limestone screenings of such gradation and quantity as required to fill the surface voids and firmly bind the loose material in place. Screenings so used in correcting segregated surface areas will be paid for as a part of the aggregate base material.
- d. Shaping and compacting shall be carried on continuously until a true, even and uniform surface of proper grade and cross-section is obtained, and until the density of the complete base is at least 95% of maximum density as determined

by AASHTO T 99. The proper moisture content shall be maintained by wetting the surface as required during shaping and compacting operations. Final rolling shall be accomplished by use of a self-propelled smooth-wheeled roller.

- e. Most repairs under this Contract will not require any additional backfill. However, when backfill is required, CONTRACTOR shall provide and install sufficient compacted aggregate backfill as required to meet the specifications.
- D. Payment:** Payment shall be made at the Contract Unit Price as listed in Section 00412 – Unit Prices and as stated in Section 01260 Measurement and Payment. Such payment and price shall constitute full compensation for all labor, materials, and equipment necessary to complete the item.

End of Section

SECTION 02205 – ASPHALTIC CONCRETE, HOT RECYCLING, & RESURFACING

Referenced Standards: **The following standards are referenced directly in this section. The latest version of these standards shall be used.**

Section 2200 of the Kansas City Public Works Design and Construction Standards
ASTM C 117 - Test Method for Materials Finer than 75- um (No. 200) Sieve in Mineral Aggregates by Washing
ASTM C 136 - Test Method for Sieve Analysis of Fine and Coarse Aggregates
ASTM D 2172 - Test Methods for Quantitative Extraction of Bitumen from Bituminous Paving Mixtures
ASTM D 6307 - Test Method for Asphalt Content of Hot-Mix Asphalt by Ignition Method
ASTM D 4552 - Practice for Classifying Hot-Mix Recycling Agent
Asphalt Institute- "Superpave Performance Graded Asphalt Binder Specification and Testing", SP-1 "Superpave Mix Design", SP-2
Asphalt Institute- "Mix Design Methods for Asphalt Concrete and Other Hot-Mix Types", MS-2, Sixth Edition

- A. General:** Except as modified herein, the recycled asphaltic concrete shall be equal to that produced as new materials meeting Section 2200 of the Kansas City Public Works Design and Construction Standards. The Reclaimed Asphalt Pavement (RAP) and/or Reclaimed Aggregate Material (RAM) shall represent a maximum of 30 percent of the composition of all surface mixtures and maximum of 50 percent of the composition for all base mixtures. Virgin Surface shall be used on all new construction projects and on restoration projects recycled surface or virgin surface may be used. Recycled base may be used as an alternate on any project. The Recycled Asphaltic Concrete, if required, shall contain a combination of RAP, RAM, coarse aggregate, fine aggregate, mineral filler, asphalt cement, recycling agent, anti-stripping agent and approved additives, to produce an acceptable mixture. Recycled Asphaltic Concretes shall be designated by prefacing the type with "RC," such as "RC Type 1-01". Fractionated RAP (FRAP) shall be recognized as fine aggregate that passes the ¼ inch screen, and coarse aggregate as that material retained on the ¼ inch screen and passing the ¾ inch screen.

The CONTRACTOR will be expected to lay the quantity of recycled mix used in the proposal regardless of the percent composition used. The CONTRACTOR will have to obtain reclaimed material from another source, at no cost to the City, or lay virgin material at the recycled unit bid price if no reclaimed material remains from the supply generated by this contract.

- B. Materials Evaluation:** The RAP and/or RAM shall have the following tests performed in addition to the usual Marshall procedures. All recycled materials shall have the following tests performed in addition to those required in 2205.3.D.

1. A sieve analysis shall be performed on RAP and/or RAM in accordance with ASTM C 117, "Standard Test Method for Material Finer than No. 200 Sieve (75 um) in Mineral

Aggregates by Washing" and ASTM C 136, "Standard Method for Sieve Analysis of Fine and Coarse Aggregates" after extraction of asphalt.

2. Asphalt content analysis shall be performed for RAP in accordance with Method "A" of ASTM D 2172, "Standard Test Methods for Quantitative Extraction of Bitumen from Bituminous Paving Mixtures" where the RAP content exceeds 30%. For mixtures with RAP contents less than 30%, asphalt content may be determined using ASTM D6307.
3. The asphalt cement used shall be determined as follows:
For all hot mix asphalt containing RAC, the asphalt grade of the post production mix shall be tested in accordance with procedures outlined in the Asphalt Institute SP-1 to ensure that the asphalt grade meets or exceeds PG64-22.
4. All sources of material for use in RAC must be approved by the Engineer prior to use.

C. Material Requirements:

1. New asphalt cements added to the aged asphalt shall meet the requirements of Section 2205.2A
2. Recycling Agents, if used, shall meet the requirements of ASTM D 4552, "Standard Practice for Classifying HOT MIX Recycling Agents."
3. The RAP and/or RAM stockpiled at the plant site shall be maintained in stockpiles separated into surface and base. The RAP and/or RAM shall be processed such that 100% will pass the 1-1/2 inch (38 mm) sieve and 90% will pass the 1-inch (25.4 mm) sieve.
4. The final product shall be free of foreign matter (e.g., old planer teeth, ice, wood, soil, broken sewer castings, loop detector wire, protective membranes, rubberized joint filler materials and foil turn lane markers, trash, debris, etc.)
5. Mix Design Requirements: The necessary steps for a final mix design for recycled mixtures, shall be done in accordance with the Asphalt Institute's Manual MS-2 Sixth Edition in the appendix entitled "Mix Design Using RAP When a change in the RAP and/or RAM percentage exceeds 15% of the original amount of RAP and/or RAM in the mix design, a new mix design must be submitted.
6. Asphalt Plant Requirements: All delivery tickets shall designate the type of recycled mix, (RC-Type 1-01, RC-Type 2-01, RC-Type 3-01, or RC-Type 4-01

D. Mix Design Requirements: The necessary steps for a final mix design for recycled mixtures shall be done in accordance with the Asphalt Institute's Manual Series No. 2 (MS-2) 6th Edition. When a change in the RAP and/or RAM exceeds 15 percent, a new mix design must be submitted.

E. Asphalt Plant Requirements: All delivery tickets shall designate the type of recycled mix, (RC-Type 01-1, RC-Type 01-2, RC-Type 01-3, or RC-Type 01-4).

F. Asphalt Plant Certification and Equipment Approval: All asphaltic concrete used on this project shall be from a "certified" plant. All asphalt paving equipment used by the CONTRACTOR or subcontractor shall meet the requirements of Section 2205.7 of the Construction and Material Specifications, Division II. For a list of "certified" asphalt plants, or to arrange for approval of the plant and equipment, consult Materials Laboratory, at 513-8700.

G. Asphalt Truck Load Limit: The maximum truck load on City streets shall not exceed 20 tons.

H. Asphaltic Concrete Mix: The mix to be used at the different locations shall be at the discretion of the Director of Public Works and shall conform to one of the mix tables in Section 2205.3 of the "Standard Construction and Materials Specifications".

I. Material Installation: The CONTRACTOR shall endeavor to minimize the length of cold longitudinal joints. At the direction of the Engineer or his representative, longitudinal joints that have been damaged by traffic or other sources, shall be sawcut or otherwise prepared to re-establish a vertical face. All transverse joints shall be prepared with a vertical face at the direction of the Engineer's representative

J. Compaction:

1. General: A minimum of three rollers shall be used for compacting mixes unless otherwise approved by the engineer. These rollers shall meet the requirements of Section 2205.7B entitled "Rollers." Additional rollers shall be used as necessary to provide specified pavement density.

Immediately after spreading, each course of the pavement mixture shall be compacted by rolling. The initial or "breakdown" rolling shall be accomplished with a steel-wheeled roller **meeting the requirements of 2205.7.B.1. and shall take place as closely behind the laydown machine as the temperature and condition of the mat will allow.** The pneumatic tired roller shall be used to knead and compact the pavement mixture following the initial rolling and preceding the final rolling. Care shall be exercised in the use of the pneumatic-tired roller to ensure that the pavement mixture is sufficiently cooled to avoid "picking up" of the mixture on the tires of the roller, and also to ensure that the pneumatic tired rolling is completed before the mixture becomes too cool to

allow satisfactory finish rolling. Final, or finish rolling shall be done with a steel- wheeled roller. The sequence of rolling operations may be changed with the approval of the engineer. All rolling shall be longitudinal, starting near the edge of the pavement **and progressing toward the center, overlapping on successive trips by not less than one-third (1/3) and no more than one-half (1/2) the width of the roller. Alternate trips of the roller shall be of slightly different lengths.**

The motion of the roller shall be slow enough at all times to avoid displacement of the hot mixture. The initial compaction roll shall be accomplished with the roller drive wheel leading the tiller wheel. Any displacement occurring as a result of reversing the direction of the roller, or from any other cause, shall be corrected immediately by the use of rakes and fresh mixture when required. To prevent adhesion of the mixture to the roller, the wheels shall be kept properly moistened, but excess water will not be permitted.

The surface of the mixture after compaction shall be smooth and true to established section and grade. Any surface which is segregated, or is in any way defective, shall be removed and replaced with fresh hot mixture at the Contractor's expense, and shall be immediately compacted to conform with the surrounding area.

2. Rolling Procedure:

a. Thin Layers (Lifts): When placing a thin lift (less than 2 in.[50 mm] compacted thickness) in single-lane width or full width, the mixture should be rolled in the following sequence:

- 1). Transverse joint.
- 2). Outside edge.
- 3). Breakdown rolling, beginning on the low side.
- 4). Intermediate rolling; same procedure as Step 3.
- 5). Finish rolling.

b. When paving a thin lift in echelon, or when abutting a previously placed lane or other lateral restraint, the mixture should be rolled in the following sequence:

- 1). Transverse joint.
- 2). Longitudinal joint.
- 3). Outside edge.
- 4). Breakdown rolling, beginning on the low side.
- 5). Intermediate rolling; same procedure as Step 4.
- 6). Finish rolling.

c. Thick Layers (Lifts): When placing a thick lift (2 in. [50 mm] or more compacted thickness) in single-lane width or full width, the mixture should be rolled in the following sequence:

- 1). Transverse joint.
- 2). Breakdown rolling, beginning 12 to 15 in.(300 to 380 mm) interior to the lower unsupported edge. The return pass shall be made with the edge of the roller 3 inches (76 mm) exterior to the unsupported edge of the pavement.
- 3). Breakdown rolling of outside edge. Repeat the process described in Step 2 above on the other longitudinal edge.
- 4). Intermediate rolling, beginning on the low side.
- 5). Finish rolling.

d. When paving a thick lift in echelon, or when abutting a previously placed lane or other lateral restraint, the mixture should be rolled in the following sequence:

- 1). Transverse joint.
- 2). Longitudinal joint.
- 3). Breakdown rolling, beginning at the longitudinal joint.
- 4). Intermediate rolling, beginning on the low side.
- 5). Finish rolling.

e. When paving in echelon, 2-3 inches (5.08-7.62 cm) of the first mat shall be left unrolled, and rolled when the joint between the lanes is rolled and after the 2nd mat is placed. Edges shall not be exposed more than fifteen minutes without being rolled. Particular attention shall be given to the construction of transverse and longitudinal joints in all courses.

f. In laying a surface mix adjacent to any finished area, it shall be placed sufficiently high so that, when compacted, the finished surface will be true and uniform. Where the grade is slight a level will be used to insure drainage to the desired outlet.

3. Transverse joints: When the transverse joint is next to an adjoining lane, the first pass shall be made with a static steel-wheeled roller moving along the longitudinal joint for a few feet. The surface will then be checked with a straightedge and corrections shall be made if necessary. The joint then shall be rolled transversely, with 6 in.(150 mm) of the drum width on the newly laid material. This operation shall be repeated with successive

passes, each covering an additional 6 to 8 in.(150 to 200 mm) of the new mat, until the entire width of a 22-46 drive roll is on the new mixture. During transverse rolling, wooden boards of the proper thickness should be placed at the edge of the pavement to give the roller a surface to drive on once it passes the edge of tile Mat. If boards are not used, transverse rolling must stop 6 to 8 in. (150 to 200 mm) short of the outside edge to prevent damaging it, and the edge must be compacted later during longitudinal rolling. Transverse joints shall be carefully constructed and thoroughly compacted to provide a smooth riding surface. If the joint has been distorted, it shall be trimmed to a line. The joint face shall be tacked before the fresh material is placed against it.

4. Longitudinal joints: Longitudinal joints shall be rolled directly behind the paving operation. The edge to be joined shall be tack coated. The paver screed shall be set to overlap the first mat by 1-2 inches (25-50 mm). The elevation of the screed above the surface of the first mat should be equal to the amount of roll-down expected during compaction of the new mat. For large aggregate mixes, the coarse aggregate in the material overlapping the cold joint should be carefully removed and wasted, leaving only the finer portion of the mixture to be pressed into the compacted lane at the time the joint is rolled. For mixes with smaller coarse aggregate, such as surface courses, the overlapping material should be pushed with a lute into a hump over the joint area prior to compaction.

5. Edges: The edges of the pavement shall be rolled concurrently with or immediately after rolling the longitudinal joint. Care shall be exercised in consolidating the material along the entire length of the edges. Before compaction, the materials along the unsupported edges shall be slightly elevated with a tamping tool or lute. This will permit the full weight of the roller wheel to bear on the material to the extreme edges of the mat. In rolling pavement edges, roller wheels shall extend approximately two inches (5cm) beyond the pavement edge, provided lateral displacement is not excessive.

6. Breakdown Rolling: Breakdown rolling shall immediately follow the rolling of the longitudinal joint and edges. Rollers shall be operated as close to the paver as necessary to obtain adequate density without causing undue displacement. The breakdown roller shall be operated with the drive wheel nearest the laydown machine. Exceptions may be made by the Engineer when working on steep slopes or super-elevated curves.

7. Intermediate Rolling: Pneumatic-tired rollers as specified in Section 2205.7B entitled "Rollers" shall be used for intermediate rolling. The intermediate rolling shall follow the breakdown rolling as closely as possible and while the paving mix is still of a temperature that will result in maximum density from this operation. Pneumatic-tired

rolling shall be continuous after the initial rolling until all of the mix placed has been compacted to the required density. Turning of pneumatic-tired rollers on the hot paving mix which causes displacement shall not be permitted.

8. Finish Rolling: The finish rolling shall be accomplished while the material is still warm enough for the removal of roller marks. All roller marks shall be 2205.8 2205.10 22-47 removed by the finish rolling operation. All rolling operations shall be conducted in close sequence.

9. In places inaccessible for the operation of standard rollers as specified, compaction shall be performed by trench rollers or others meeting the requirements of Section 2205.7B entitled "Rollers." The trench roller shall be operated until the lift is thoroughly compacted. Hand tamping, manual or mechanical, may be used in such areas, if such operations will give the required

K. Spot Patching: All soft areas shall be repaired by spot patching prior to paving

L. Paving Restrictions: All paving shall be completed during the daylight hours. No paving shall begin before sunrise. All paving shall cease a minimum of one-half (1/2) hour before sunset to allow rolling to be completed during daylight hours.

M. Cleanup: Before resurfacing has begun, the CONTRACTOR shall clean and dispose of all dirt, trash, and debris from the street.

All extra material resulting from paving shall be confined to the R-O-W and removed within 48 hours. Cleanup activities before and after resurfacing and spot patching shall be confined to impervious surfaces. No debris shall be placed or remain in "grass" areas, or interfere with ingress/egress of abutting properties. The unit price for asphaltic concrete shall include all costs for disposal and hauling of excess and waste asphalt materials.

N. Payment: Payment will be made at the applicable contract price per square foot by patch size based on a two (2) inch pavement thickness or per ton as listed in Section 00412 – Unit Prices and as stated in Section 01260 – Measurement and Payment.

End of Section

SECTION 02315 – FLOWABLE FILL

1. **General:** Where specified by the CITY, areas shall be backfilled with flowable fill. Flowable Fill shall be in accordance with the KC Water "Standard Specifications and Design Criteria." Section 00412 – Unit Prices includes an estimated amount of "Flowable Fill, placed". The actual amount may be greater, less, or none at all.
2. **Details:** The material shall be placed uniformly in the repair area and struck-off so the top is level and at the proper slope and grade. Materials tickets shall be provided when requested for all material placed. The flowable fill shall be of the diggable type with the strengths conforming to the requirements of the KC Water "Standard Specifications and Design Criteria."
3. **Materials:** Controlled Low Strength material (CLSM)
 - A. Materials:
 1. Portland cement Type I or Type II conforming to ASTM C150.
 2. Fly ash conforming to ASTM C618 for Class C.
 3. Fine aggregate conforming to ASTM C33.
 4. Water, clean and potable conforming to ASTM C1602.
 5. Shrinkage compensation shall be proportioned in accordance with the manufacturer's recommendations and as tested by ASTM C940.
 6. Admixtures for air entrainment or for other purposes shall conform to ASTM C494 or other appropriate standards referenced by the manufacturer. Admixtures shall only be used when specified in the Contract Documents.
 - B. Mixture Design:
 1. Mix design for CSLM shall meet the requirements of Kansas City Public Works Department Specification Section 2600, except that the maximum compressive strength shall be from 50 to 125 psi and shall be removable without using a breaker and without damaging the utility.
 2. The unit weight of the CLSM shall be a maximum of 120 pounds per cubic foot.
 - C. Quality Control:
 1. CLSM material shall be provided from a City-approved concrete plant. Contractor shall submit name and location of plant to be used.
 2. One set of cylinders for compressive strength testing shall be obtained once per day or for every 100 cubic yards of flowable backfill placed.
 3. Cost for Quality Control shall be included in the Bid Price. No separate measurement or payment shall be made.
4. **Payment:** Payment shall be made at the Contract Unit Price as listed in Section 00412 – Unit Prices and as stated in Section 01260 – Measurement and Payment. Such payment and price shall constitute full compensation for all labor, materials, and equipment necessary to complete the item. The actual amount may be greater, less or none at all.

End of Section

SECTION 02770 – Portland Cement Concrete Curbs

- A. General:** The curbs shall conform to the Standard Drawing C for Type C-1, CG-1, CG-2, or CS Curb. CONTRACTOR shall match the adjacent existing curb type.
- 1. Removal of Existing Curb:** Removal of existing curb shall be considered work incidental to construction of the proposed curb or curb and gutter. Where existing pavement is damaged, pavement shall be sawed two (2) inches deep parallel and/or perpendicular to the curb and gutter, pavement removed to a depth of at least two (2) inches and patched with asphaltic concrete. CONTRACTOR shall dispose of all removed materials.
 - 2. Non-Standard Curb:** Where non-standard curb exists, it shall be replaced with the applicable standard curb, maintaining approximate alignment at the back of the existing curb and tapering into adjacent remaining curb.
 - 3. Curbs on Corner Radii:** Where Type C-1 or Type CS curb is at a corner radius, the sidewalk and "curb section" shall be constructed monolithically and a false joint shall be tooled at the appropriate back of curb location as directed by the Engineer. Type CG-1 or CG-2 curb shall be constructed conforming to Standard Drawing SW-1.
- B. Curb Drains:** Where existing curb drains are encountered within the public right-of-way, the Contractor shall restore an adequate length of drain material which shall extend through, but not extrude past, the face of the curb section being replaced. Curb drains shall be reinstalled at a grade adequate to facilitate drainage from the existing structure. Curb drain restoration shall be considered incidental to the curb reconstruction.
- C. Payment:** Payment will be made at the contract unit bid prices per linear foot for curb as listed in Section 00412 – Unit Prices and as stated in Section 01260 – Measurement and Payment. This pricing shall include all Work in this section and any incidental costs needed to complete the Work.

End of Section

SECTION 02775 – PORTLAND CEMENT CONCRETE SIDEWALKS, DRIVEWAYS, and ADA ACCESSIBLE RAMPS

Referenced Standards:

The following standards are referenced directly in this section. The latest version of these standards shall be used. If conflicting standards are referenced, the more stringent standard shall apply.

ADAAG – ADA Accessibility Guidelines Section 4.7 – Curb Ramps

PROWAG - Public Rights-of-Way Accessibility Guideline

Section 2301 of the Kansas City “Standard Specifications and Design Criteria”

A. Sidewalks:

1. **General:** Portland Cement Concrete sidewalk shall be a minimum of four (4) inches thick and shall conform to the requirements of Standard Drawing SW-1. The Contractor shall be responsible for the cost of providing fill material consisting of untreated compacted aggregate within the top six (6) inches of subgrade. During construction, care shall be taken to ensure public safety along the sidewalk. Minor variations in alignment shall be permitted on all sidewalk locations to save some trees and other structures of permanent nature. All curb boxes, tile covers and meter pit covers shall be adjusted to grade and movable portions shall be left free and clean. CONTRACTOR shall dispose of all remaining materials on site.
2. **Joints:** All expansion and contraction joints shall be reconstructed and all catch basins, poles, fire hydrants, manholes and fire alarm bases shall be adjusted to grade and boxed in with expansion joints. Expansion material shall be located as directed by the City. Wherever possible, the expansion joints shall be located in lieu of other joints giving the sidewalk an appearance of continuity. Expansion joints shall be constructed where the new sidewalk abuts existing sidewalk, curb or driveways.
3. **Payment:** Payment will be made at the contract unit bid prices per square foot for the applicable type of sidewalk as listed in Section 00412 – Unit Prices and as stated in Section 01260 – Measurement and Payment. These prices shall be inclusive of all work described in this section including any incidental costs needed to complete the Work, such as restoring the area where formwork is removed.

B. Driveways:

1. **General:** When driveways need to be repaired Contractor shall restore driveway to the original dimensions and thickness unless directed otherwise by CITY. The Contractor shall be responsible for the cost of providing fill material

consisting of untreated compacted aggregate within the top six (6) inches of subgrade. Driveways shall be reconstructed to existing joints, will match the existing surface texture, and will not pond.

2. **Driveway Curb:** No separate payment will be made for curb transitions on driveway flares or radii. Work shall be considered incidental to driveways and all costs shall be included in the contract unit bid price for driveways as listed in section 00412 – Unit Prices.
3. **Payment:** Payment will be made at the contract unit bid prices per square foot for the applicable type of driveway as listed in Section 00412 – Unit Prices. These prices shall be inclusive of all work described in this section including any incidental costs needed to complete the Work.

C. **ADA Accessible Ramps with Detectable Warning:**

1. **General:** Detectable warnings are required standardized surface features built in or applied to walking surfaces on sidewalks or ramps to warn visually impaired people of hazards on circulation path. ADA accessible ramps shall conform to the details as shown in this Project Manual or the most current ADA specifications. The Contractor shall be responsible for the cost of providing fill material consisting of untreated compacted aggregate within the top six (6) inches of subgrade. **See attached General Notes and Curb Ramp Templates.**
2. **Contrast:** Detectable warnings shall contrast visually with adjoining surfaces, either light-on-dark or dark-on-light. The material used to provide contrast should contrast by at least 40%. Contrast in percent is determined by:

$$\text{Contrast} = [(B1-B2)/B1] \times 100$$

Where:

B1 = light reflectance value (LRV) of the lighter area

B2 = light reflectance valve (LRV) of the darker area

Light Reflectance Value shall be determined by ASTM D2805 for painted surfaces or by visual comparison to paint chips with LRVs determined by ASTM D2805 for non-painted surfaces. The material used to provide contrast shall be an integral part of the walking surface.

4. **Payment:** Payment for Detectable Warning will be made at the contract unit bid price per square foot for “ADA Ramp Detectable Warning” as listed in Section 00412 – Unit Prices. These prices shall be inclusive of all work described in this section including any incidental costs needed to complete the Work.

General Notes

1. ADA curb ramp construction is a major infrastructure improvement and requires detailed design spot elevations and slopes.
2. All areas of the pedestrian access route must be compliant with Section 2300 of the KCMO Public Works Standards and PROWAG. Any areas with slopes that are not in compliance with Section, will be removed and replaced.
3. Sidewalk sections shall be 4 inches thick, except where required to be thicker such as driveway crossings, Parks and Recreation right of way, etc., as shown on other Standard Drawings or approved plans. All curb ramps, lower landings adjacent to the curb and concrete slabs containing detectable warning surface (DWS) shall be a minimum of 8 inches thick. Sidewalk joints and edges shall be "Picture Framed" with the joint being a minimum 1/4th the depth of the slab. Finished sidewalk shall be a stable, slip resistant surface, and does not pond water. Pedestrian access route shall continue across driveways.
4. Curb ramp running slope shall be a maximum of 8.3 percent and the maximum cross slope shall be 2 percent. The running slope shall not require the ramp length to exceed 15 feet. Where necessary to slope the curb ramp greater than 8.3 percent in order to the into sidewalk slopes that follow the street slope, the curb ramp shall be a minimum of 16 feet long. At these locations any adjacent ramp shall be sloped to minimize the slope of the ramp in excess of 8.3 percent.
5. Do not scale drawing, follow dimensions.
6. The sub-grade shall conform to Standard Specifications Section 2301.3 (B). The sidewalk and ramp located within the street Right-of-Way (R/W) shall conform to Standard Specifications Section 2301.2. Expansion joint filler and joint sealing compound shall conform to Standard Specifications Sections 2301.4,B and 2301.7. Curing membranes shall conform to Standard Specifications Section 2301.5.
7. It is preferable that the curb ramp and turning space (if required) be constructed at the same time as the construction of the curb or ensure that the curb section at the curb ramp opening meets APWA 5200 and PROWAG.
8. Storm water inlets, signs, posts, manhole covers, pull boxes, and other access lids should be avoided within the sidewalk. If such a location is necessary, the feature must meet ADA Standards. Mailbox placement should also be avoided in the sidewalk. Utility poles will not be allowed in the sidewalk accessible route. An accessible route must have a minimum 4 feet clear width.
9. Where a curb ramp meets the pavement, the transition from the sidewalk to the gutter to the roadway surface must be flush. When monolithic concrete curb is constructed, strike a joint across the bottom of the ramp at the curb line.
10. Landings shall be constructed at the top and/or bottom of a curb ramp wherever a turning movement or access to a pedestrian push button is required. Landings located in the roadway must be completely contained within a crosswalk and out of a projected lane or actual lane of traffic.
11. The DWS type shall be "Cast-in-Place with replaceable panels" unless approved by the engineer (both new and retrofit application) and shall comply with ADA Standards. The DWS shall be Brick Red in color unless approved by the engineer.
12. Ramp types 5A, 5B, and 5C to be used in reconstruction only.
13. At signalized intersections and ADA ramps designs including pedestrian push button locations, designs shall be approved by the City Engineer.
14. Conditions outside of standard drawings must be designed and then approved by the City Engineer. Where applied to existing conditions, curb replacement and pavement wedging may be required.

Adopted
_____ DATE
_____ BY
_____ TITLE
Kansas City, Missouri Public Works Department

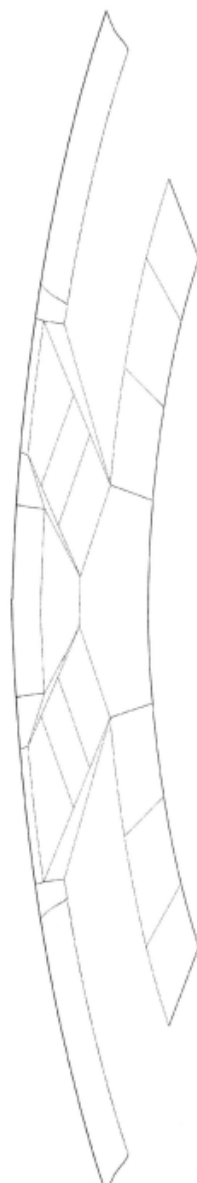
Curb Ramp Template General Notes Page 1 of 17

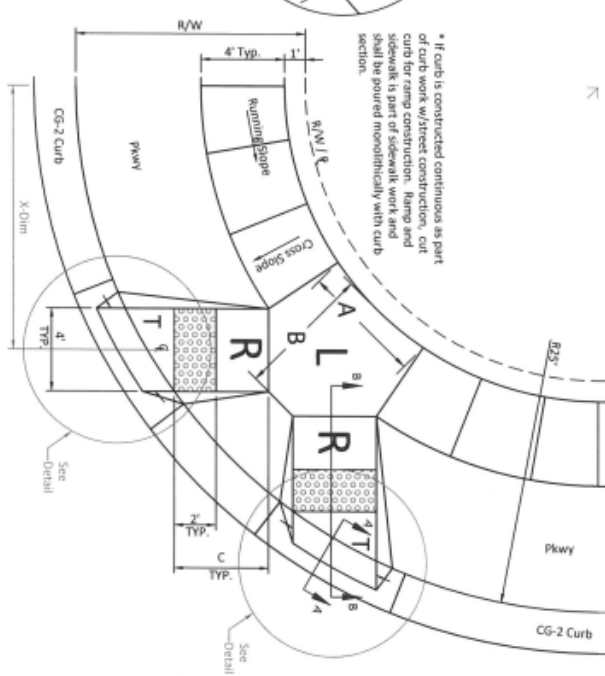

Type 1A

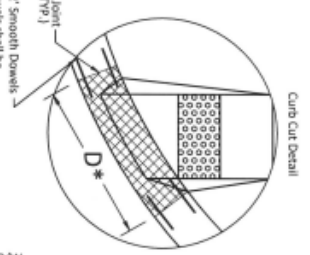

* If curb is constructed continuous as part of curb work w/street construction, cut curb for ramp construction. Ramp and sidewalk is part of sidewalk work and shall be poured monolithically with curb sections.



Expansion Joint Material (Typ.)
5/8" ϕ x 2' Smooth Dowels (Typ.) Dowels shall be greased and wrapped on one end with Expansion Tubes.

Letter	Dimensions Eng. Detailed Design Dim.	Comments
A	5'-9.1"	Field Dim. May Vary
B	6'-5.7"	Field Dim. May Vary
C	7'-5.3"	Field Dim. May Vary
D*	12'-7.1/4"	Curb to be Removed Field Dim. May Vary

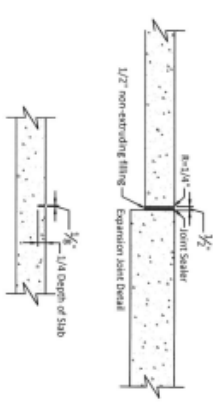
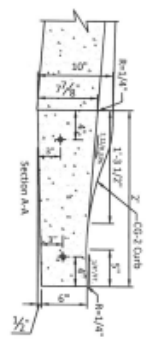

Residential 25' Radius 11' R/W

Adopted

Director of Public Works _____ Date _____
 Kansas City, Missouri
 Public Works Department
 Curb Ramp Template

Page 2 of 17
 Standard Drawing Number Type 1A



Templates to be used with general notes page.

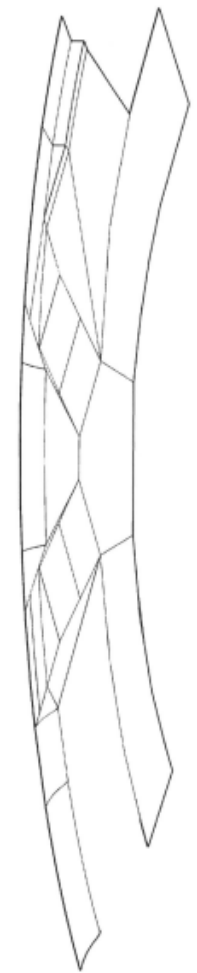
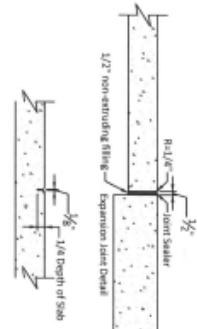
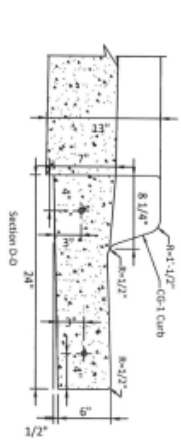
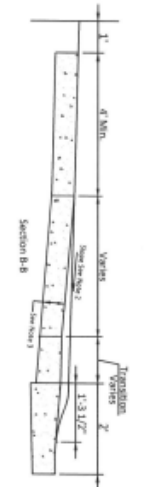
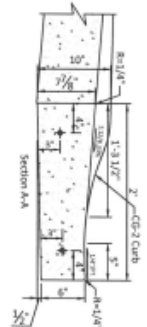

Type 1B

Curb Call Detail

* If curb is constructed continuous as part of curb work w/street construction, cut curb for ramp construction. Ramp and sidewalk is part of sidewalk work and be poured monolithically with curb section.

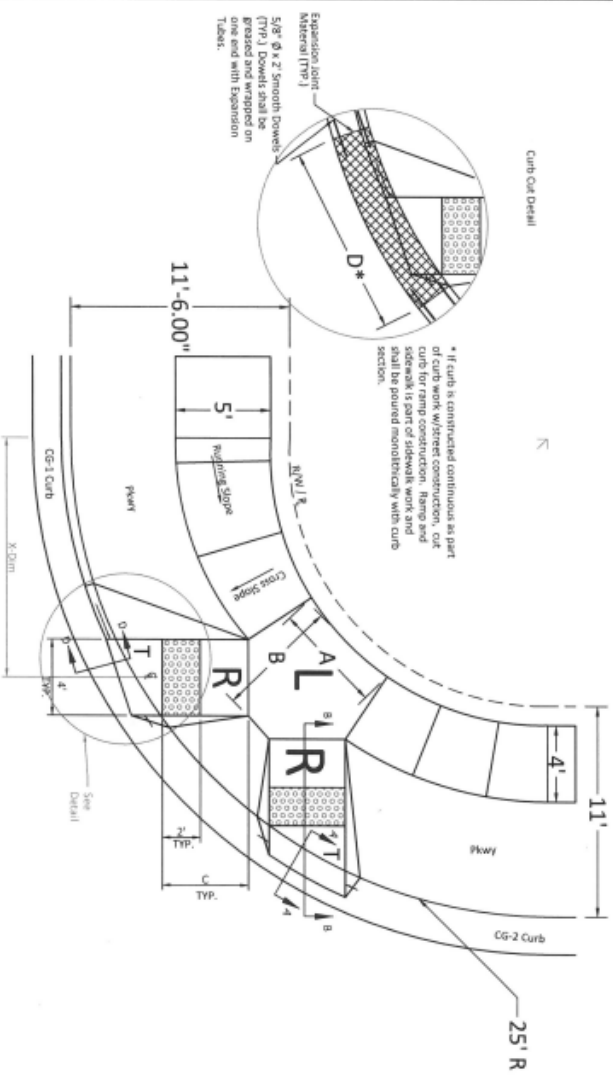

Letter	Eng. Detailed Design Dim.	Comments
A	5'-9.0"	Field Dim. May Vary
B	6'-5.5"	Field Dim. May Vary
C	9'-11.3"	Field Dim. Curb to be Removed
D*	12'-6.75"	Field Dim. May Vary

Residential Collector
 25' Radius
 11' - 11'-6" R/W

Adopted

Director of Public Works _____
 City No. _____ Date _____

Kansas City, Missouri
Public Works Department

Curb Ramp Template

Templates to be used with general notes page.

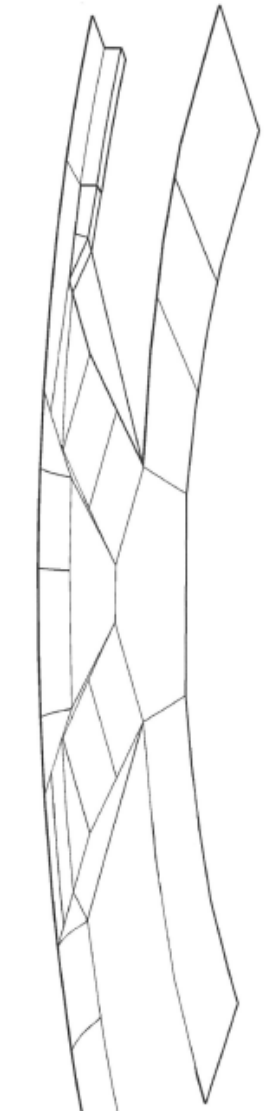

Type 1C

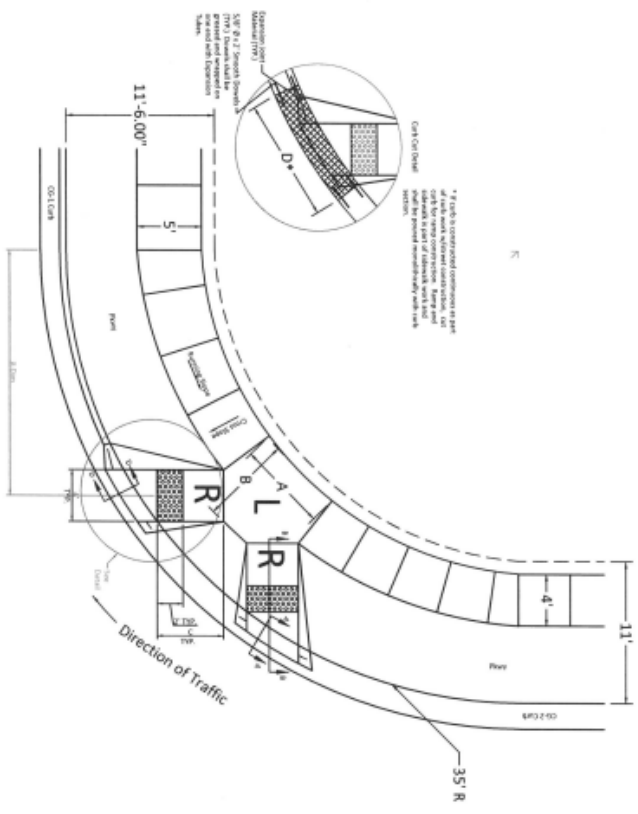
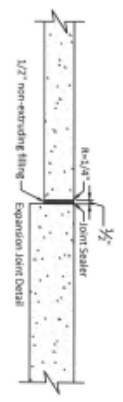
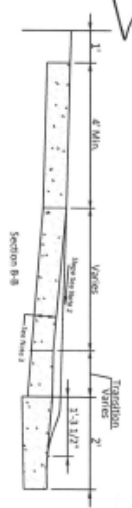
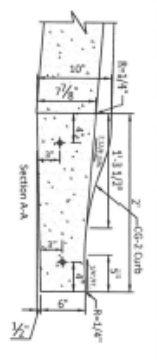

Letter	Eng. Detailed Dim.	Comments
A	6'-11.5"	Field Dim. May Vary
B	6'-11.8"	Field Dim. May Vary
C		Field Dim. May Vary
D*	9'-5.03"	Curb to be Removed
X-Dim	19'-0.36"	Field Dim. May Vary

Legend
 Radius Point
 L Landing
 R Ramp

Residential Collector
 35' Radius
 11' - 11'-6" R/W

Adopted

Kansas City, Missouri
 Public Works Department
 Curb Ramp Template

Templates to be used with general notes page.

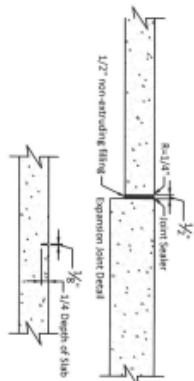
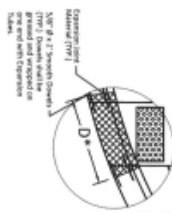
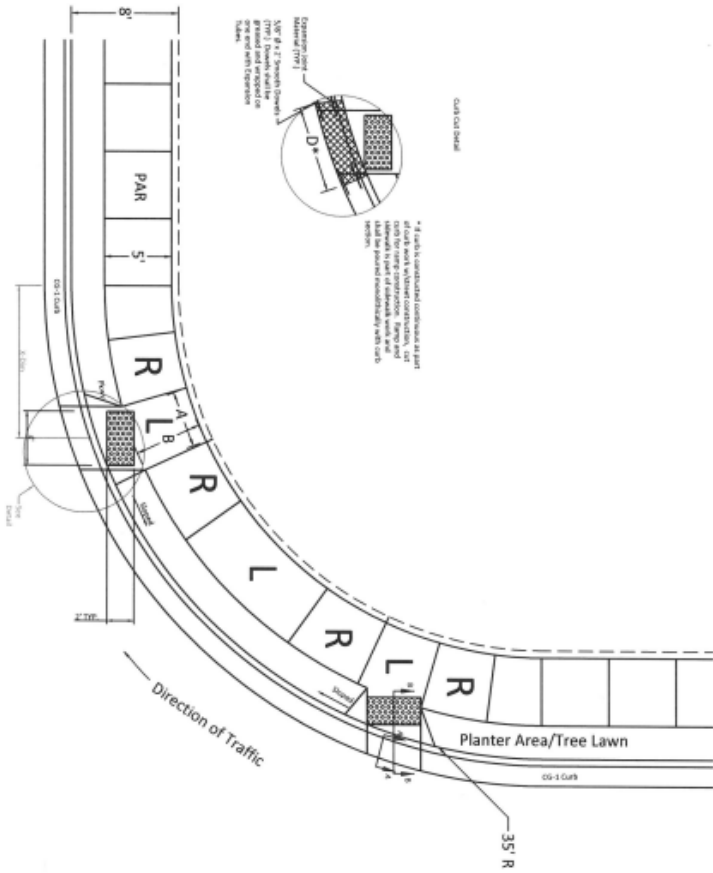
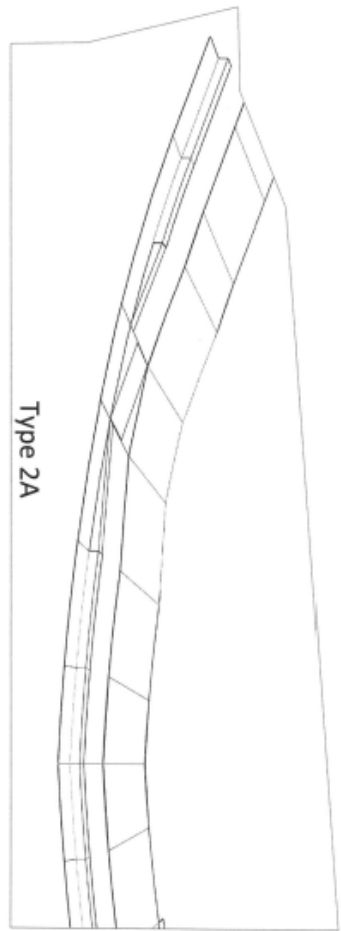

- Legend**
- \curvearrowright Radius Point
 - L Landing
 - R Ramp
 - PAR Pedestrian Access Route

Letter	Eng. Detailed Design Dim.	Comments
A	4'-2"	Field Dim. May Vary
B	5'-0"	Field Dim. May Vary
C		Field Dim. May Vary
D*	6'-5.0"	Field Dim. May Vary
X-Dim	11'-4.0"	Field Dim. May Vary

Adopted

**35' Radius
8' R/W**

Kansas City, Missouri
Public Works Department

Curb Ramp Template

Page 5 of 17

Type 2A

Templates to be used with general notes page.

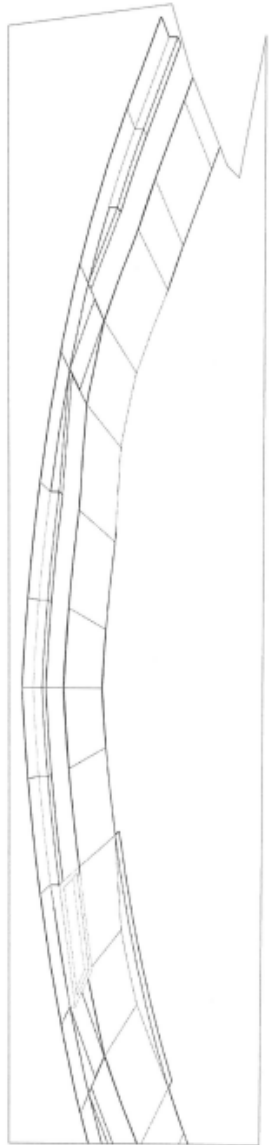

Type 2B

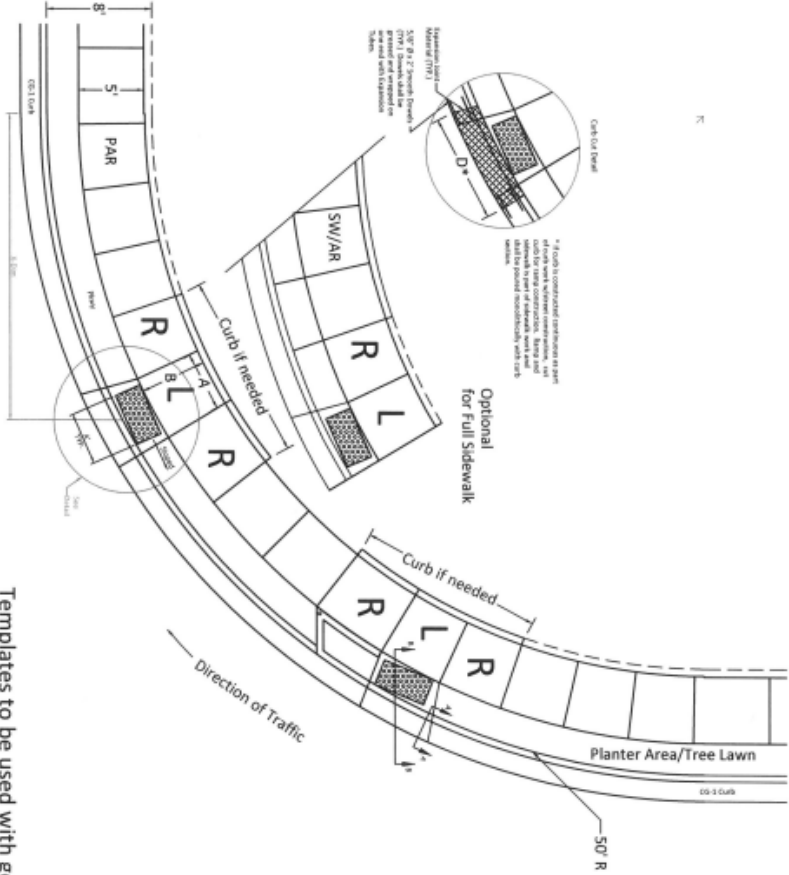

Templates to be used with general notes page.

Letter	Eng. Detailed Design Dim.	Comments
A	4'-5.6"	Field Dim. May Vary
B	5'-0"	Field Dim. May Vary
C		Field Dim. May Vary
D+	8'-2.16"	Curb to be Removed Field Dim. May Vary
X Dim	23'-2.7"	Field Dim. May Vary

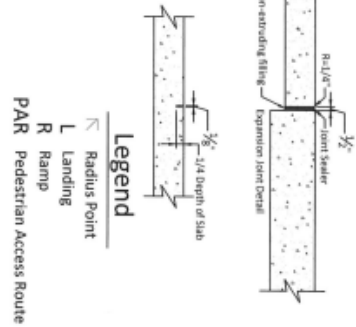
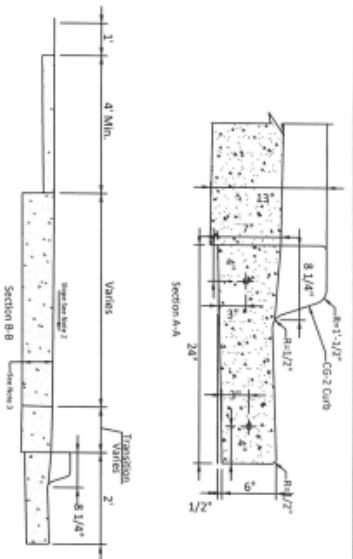

50' Radius
8' R/W

Adopted

Director of Public Works _____

City of _____

Kansas City, Missouri
Public Works Department

Curb Ramp Template

Standard Drawing Number: _____

Page 6 of 17

Type 2B

Templates to be used with general notes page.

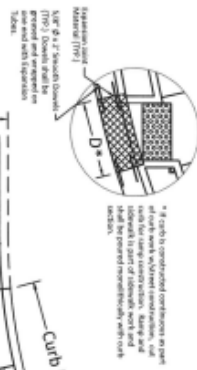
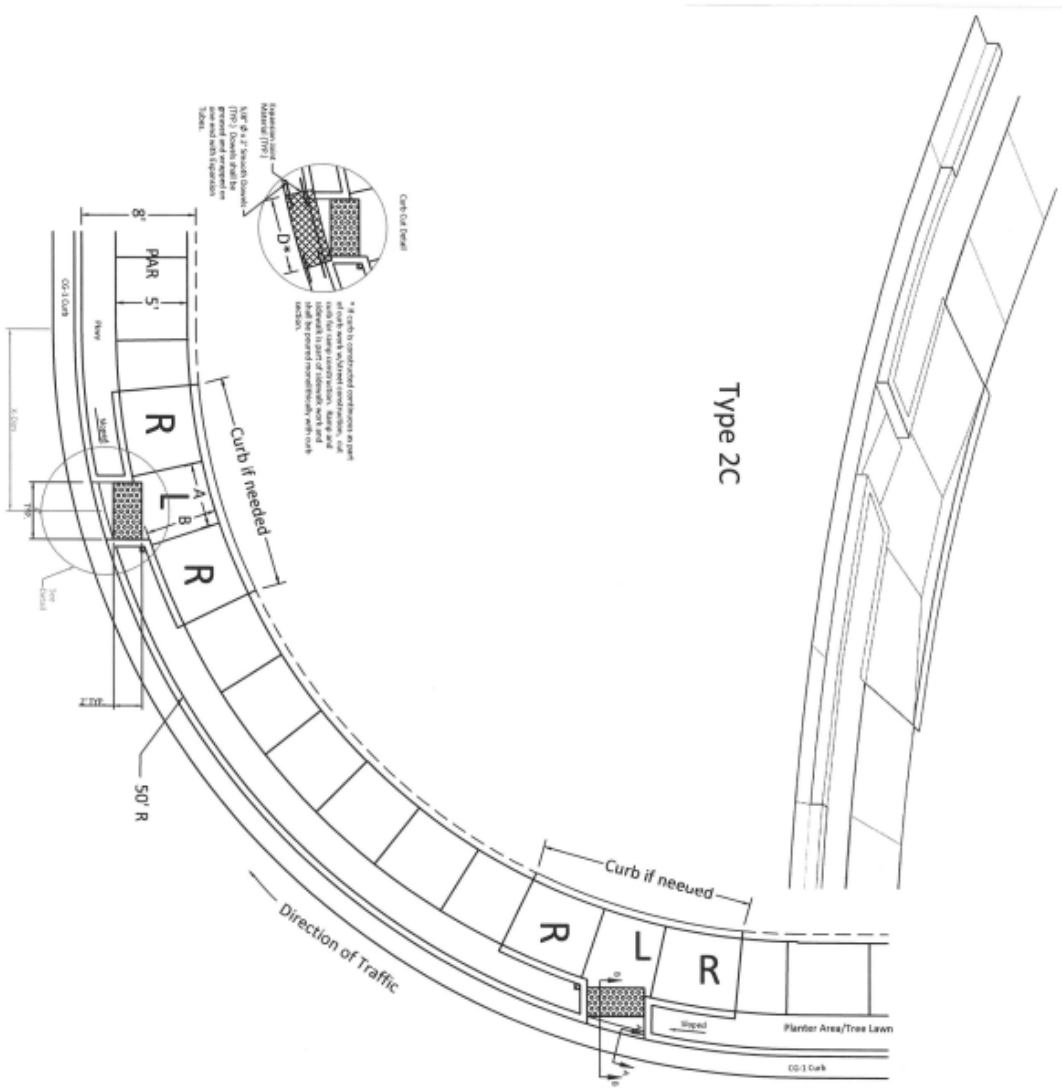

Type 2C

Letter	Dimensions Eng. Detailed Design Dim.	Comments
A	4'-5.7"	Field Dim. May Vary
B	5'-0.0"	Field Dim. May Vary
C	5'-3.7"	Field Dim. May Vary
D*	5'-3.7"	Curb to be Removed
X-Dim	12'-8.4"	Field Dim. May Vary

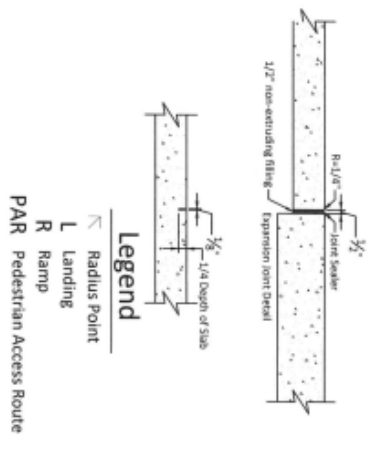
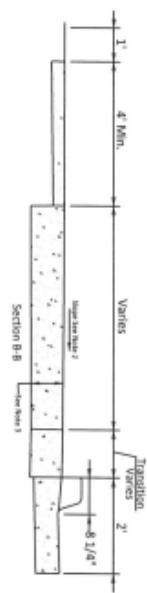
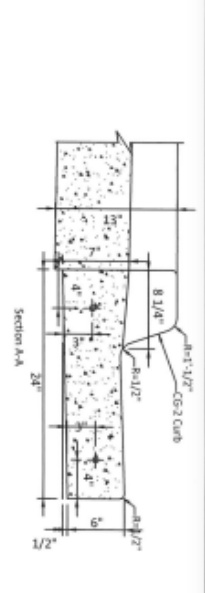

50' Radius
8' R/W

Adopted

 Director of Public Works

 Date

Kansas City, Missouri
Public Works Department

Curb Ramp Template

Page 7 of 17

Standard Drawing Number
Type 2C

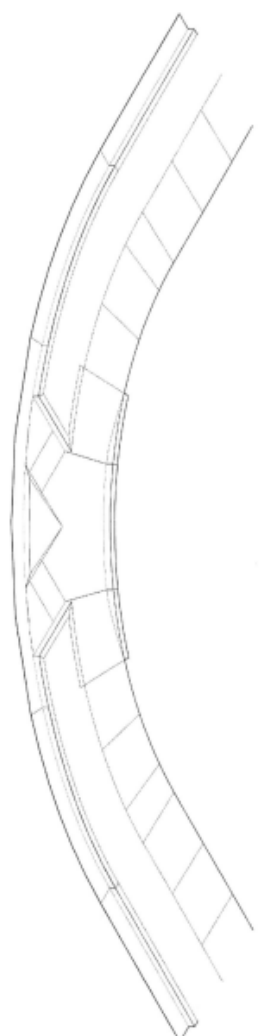

Type 3A

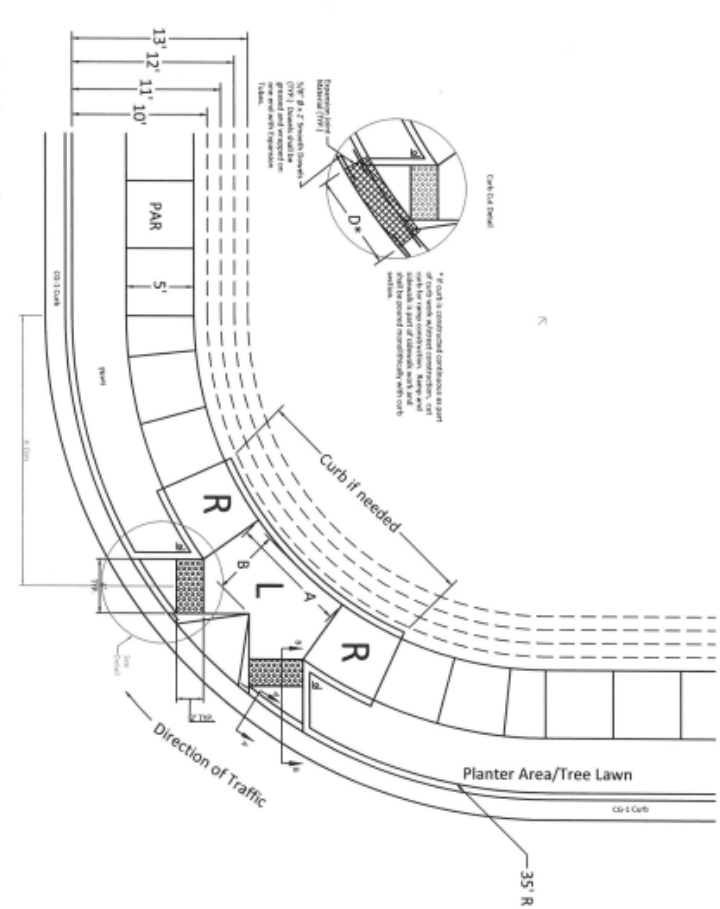

Letter	Dimensions	Eng. Detailed Design Dim.	Comments
A	8'-9.0"	Field Dim.	Field Dim. May Vary
B	5'-0.0"	Field Dim.	Field Dim. May Vary
C		Field Dim.	Field Dim. May Vary
D*	7'-0.3"	Field Dim.	Field Dim. May Vary
X Dim	19'-11.0"	Field Dim.	Field Dim. May Vary

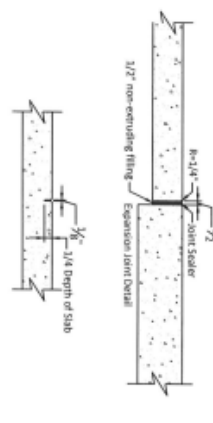
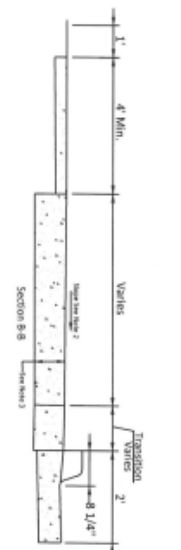
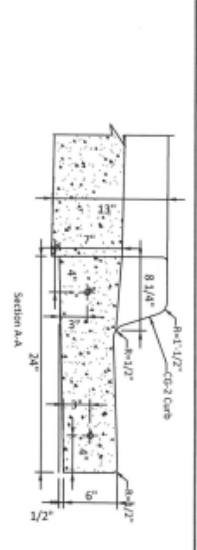

- Legend**
- R Radius Point
 - L Landing
 - R Ramp
 - PAR Pedestrian Access Route

35' Radius
10' to 13' R/W

Adopted

Kansas City, Missouri
Public Works Department

Curb Ramp Template

Page 8 of 17

Type 3A

Templates to be used with general notes page.

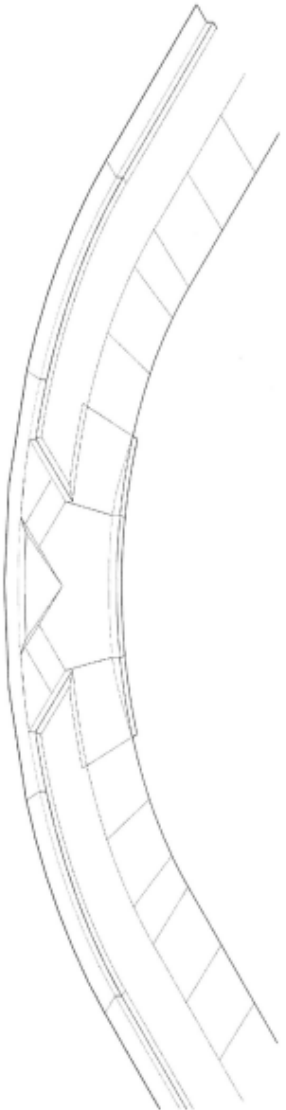

Type 3B

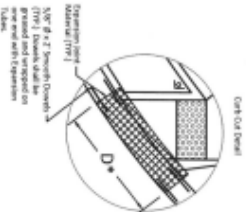
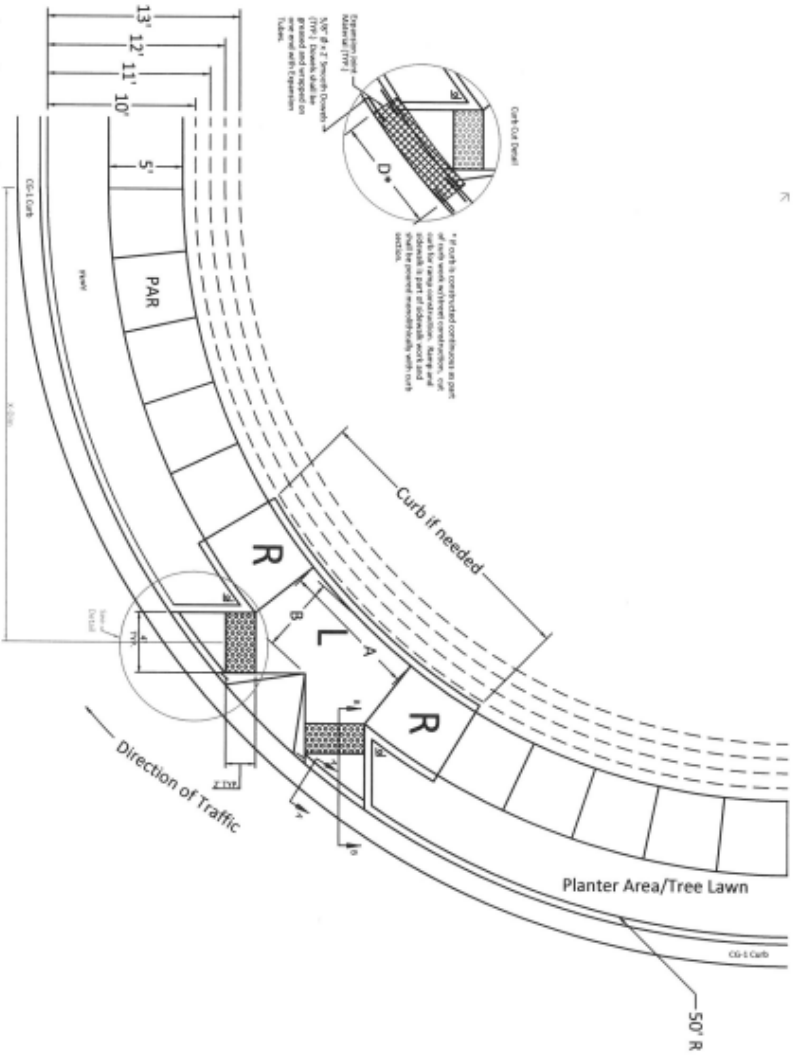

1" finish is recommended for concrete to provide a smooth surface. A 1/2" thick concrete curb is recommended for use with a 1/2" thick concrete ramp. A 1/2" thick concrete curb is recommended for use with a 1/2" thick concrete ramp. A 1/2" thick concrete curb is recommended for use with a 1/2" thick concrete ramp.

Letter	Design Dim.	Field Dim.	Comments
A	9'-3.4"	May Vary	Field Dim. May Vary
B	5'-0.0"	May Vary	Field Dim. May Vary
C	7'-2.1"	May Vary	Field Dim. May Vary
D*	30'-6.30"	May Vary	Curb to be Removed Field Dim. May Vary

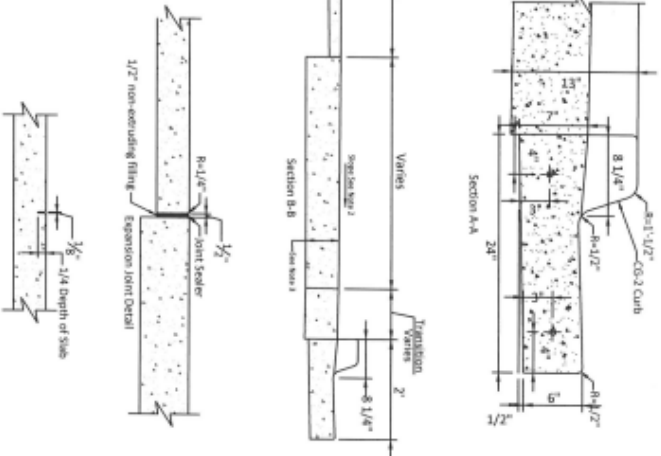

- Legend
- Radius Point
- L Landing
- R Ramp
- PAR Pedestrian Access Route

50' Radius
10' to 13' R/W

Adopted

Kansas City, Missouri
 Public Works Department
 Curb Ramp Template
 Page 9 of 17
 Type 3B

Templates to be used with general notes page.

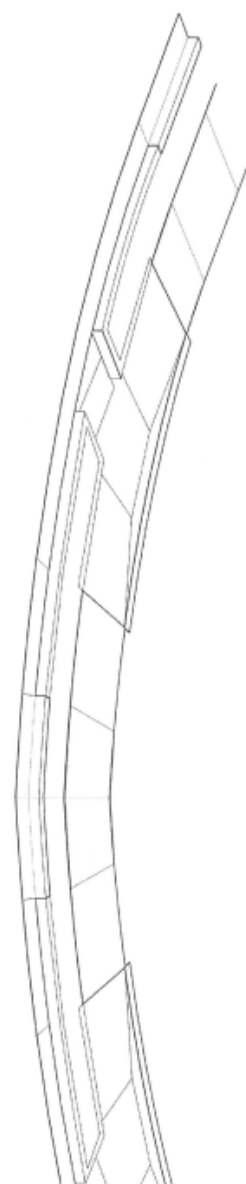

Type 3C

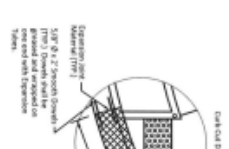
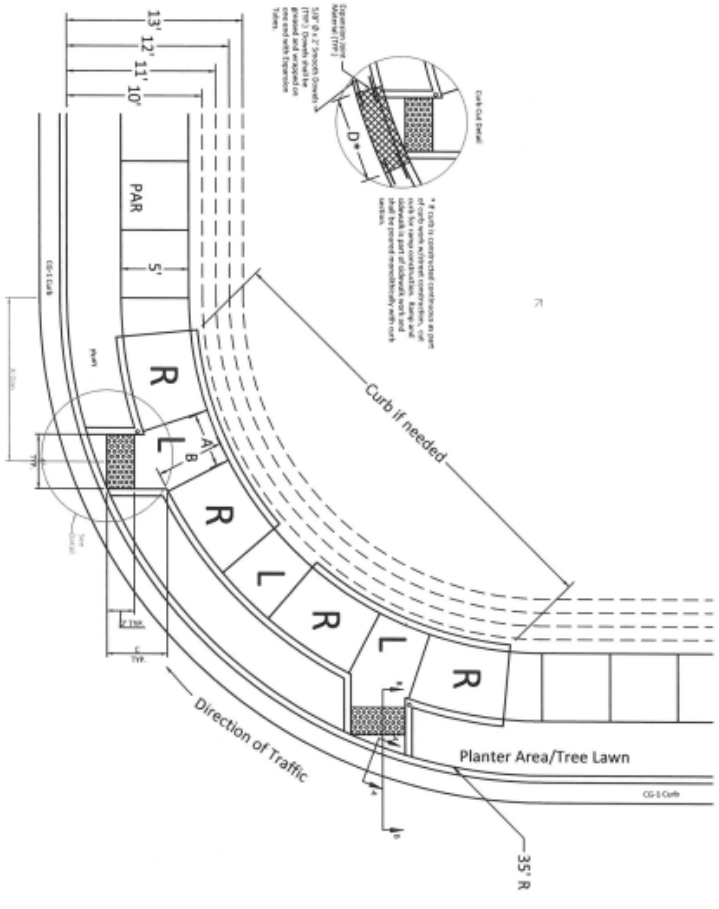

* 4 inch compacted concrete curb in place of curb work with per concrete. Curb should be placed in front of sidewalk and shall be formed immediately with curb sections.

Expansion joint
 1/2" non-eroding filling
 expansion joint detail

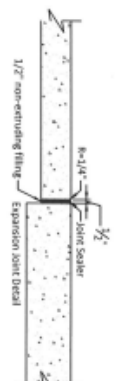
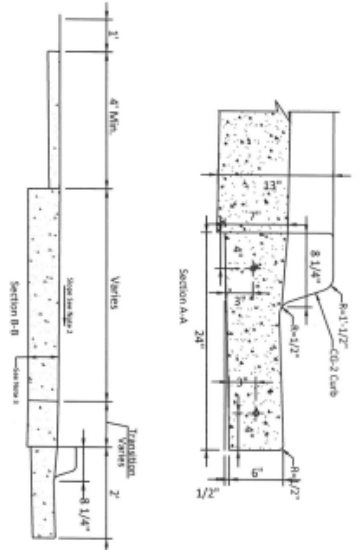

Legend

- R Radius Point
- L Landing
- R Ramp
- PAR Pedestrian Access Route

35' Radius
 10' to 13' R/W

Letter	Eng. Detailed Design Dim.	Comments
A	4'-0"	Field Dim. May Vary
B	5'-0"	Field Dim. May Vary
C	6'-3.5"	Field Dim. Curb to be Removed May Vary
D*	12'-0.9"	Field Dim. May Vary

Adopted

Kansas City, Missouri
 Public Works Department
 Curb Ramp Template

Page 10 of 17
 Type 3C

Templates to be used with general notes page.

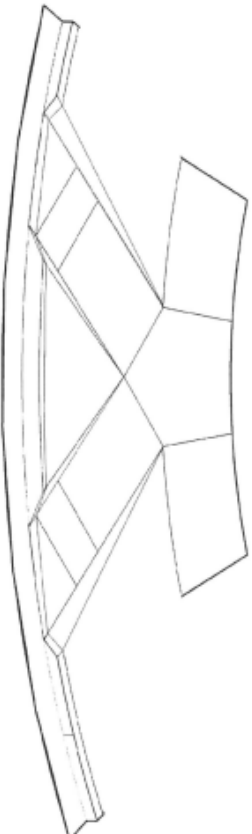

Type 4A

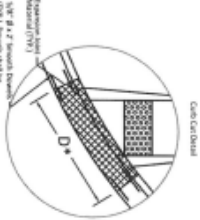

Curb Detail
3/4" R-1/4" (3/4" Depth of Curb)
0°

* If curb is constructed continuous in part of curb work, without construction, curb is to be poured monolithically with curb and be poured monolithically with curb.

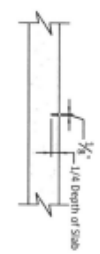
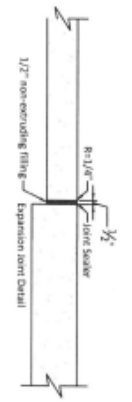
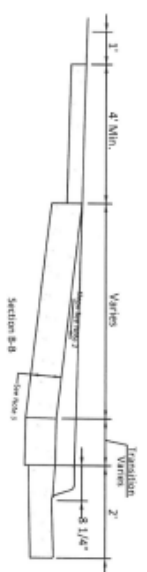
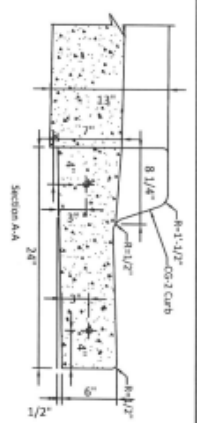
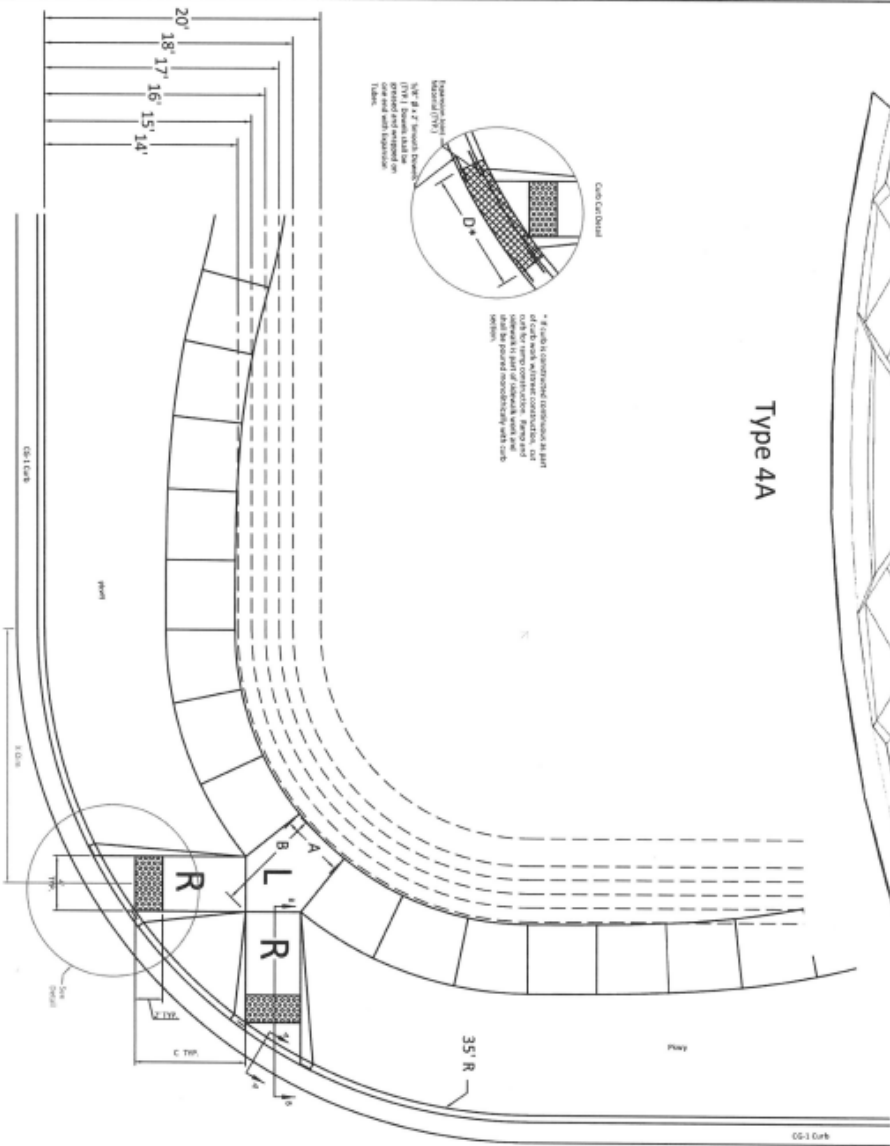

- Legend**
- R Radius Point
 - L Landing
 - R Ramp
 - PAR Pedestrian Access Route

Letter	Dimensions (Eng. Detailed Design Dim.)	Comments
A	4'-3.0"	Field Dim. May Vary
B	7'-8.0"	Field Dim. May Vary
C	8'-3.7"	Field Dim. May Vary
D*	18'-5.0"	Field Dim. May Vary

Adopted

35' Radius
14' to 20' R/W

Kansas City, Missouri
Public Works Department

Curb Ramp Template

Page 11 of 17 Type 4A

Templates to be used with general notes page.

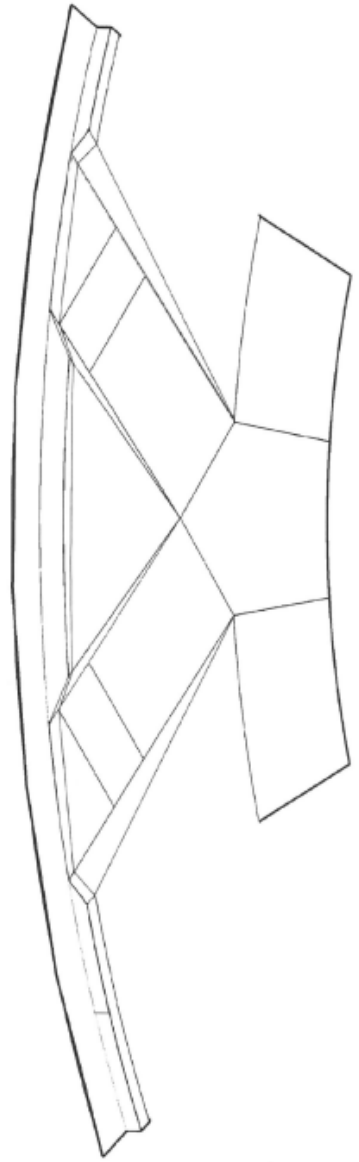

Type 4B

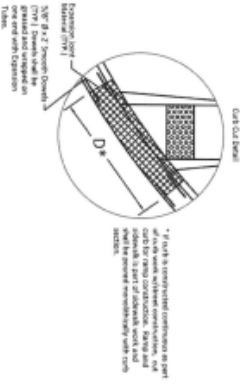
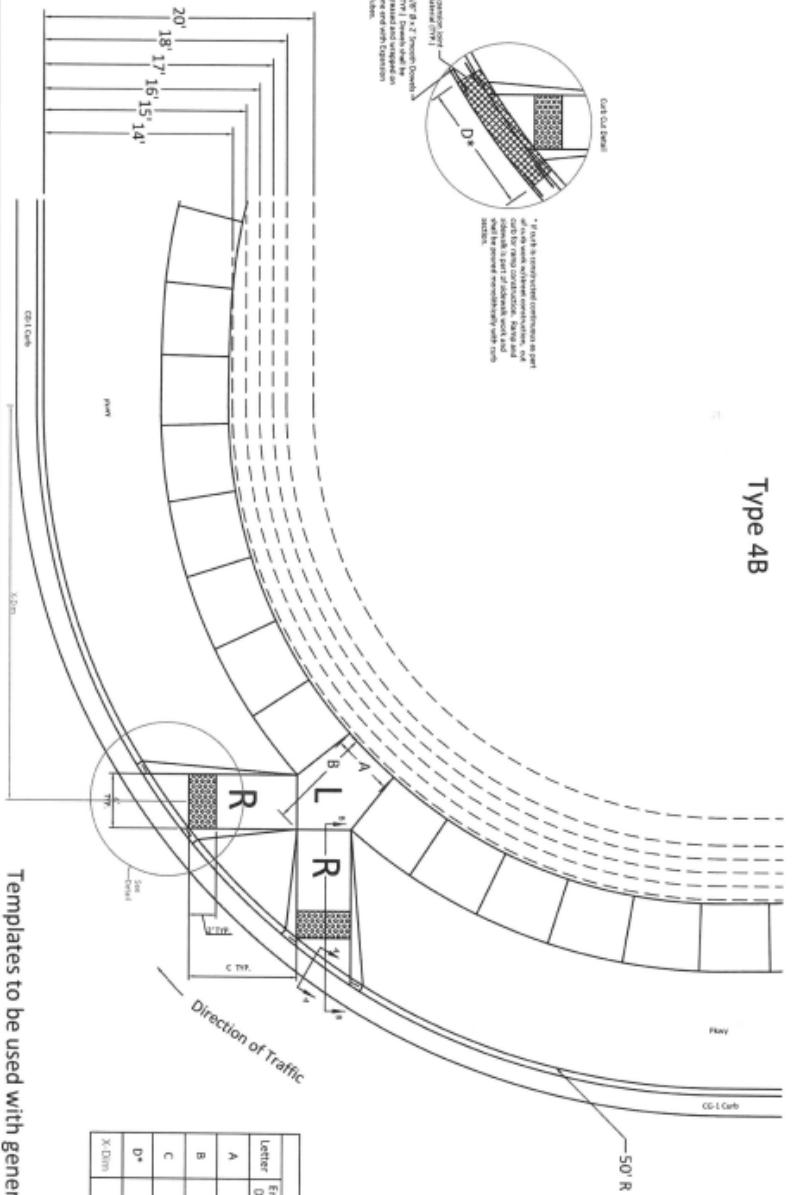

Letter	Dimensions	Eng. Detailed Design Dim.	Comments
A	4'-7.0"	Field Dim.	Field Dim. May Vary
B	7'-9.0"	Field Dim.	Field Dim. May Vary
C	9'-5.6"	Field Dim.	Field Dim. May Vary
D*	29'-1.6"	Field Dim.	Field Dim. May Vary

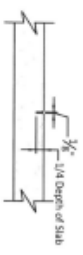
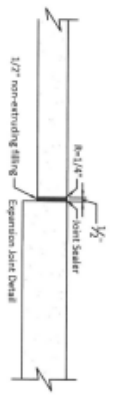
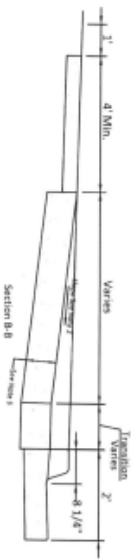
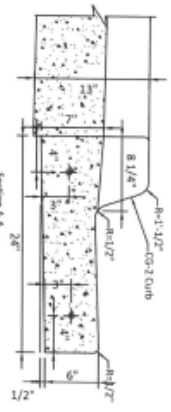

- Legend**
- ⊙ Radius Point
 - L Landing
 - R Ramp
 - PAR Pedestrian Access Route

50' Radius
14' to 20' R/W

Adopted

Kansas City, Missouri
 Public Works Department
 Curb Ramp Template
 Page 12 of 17
 Type 4B

Templates to be used with general notes page.

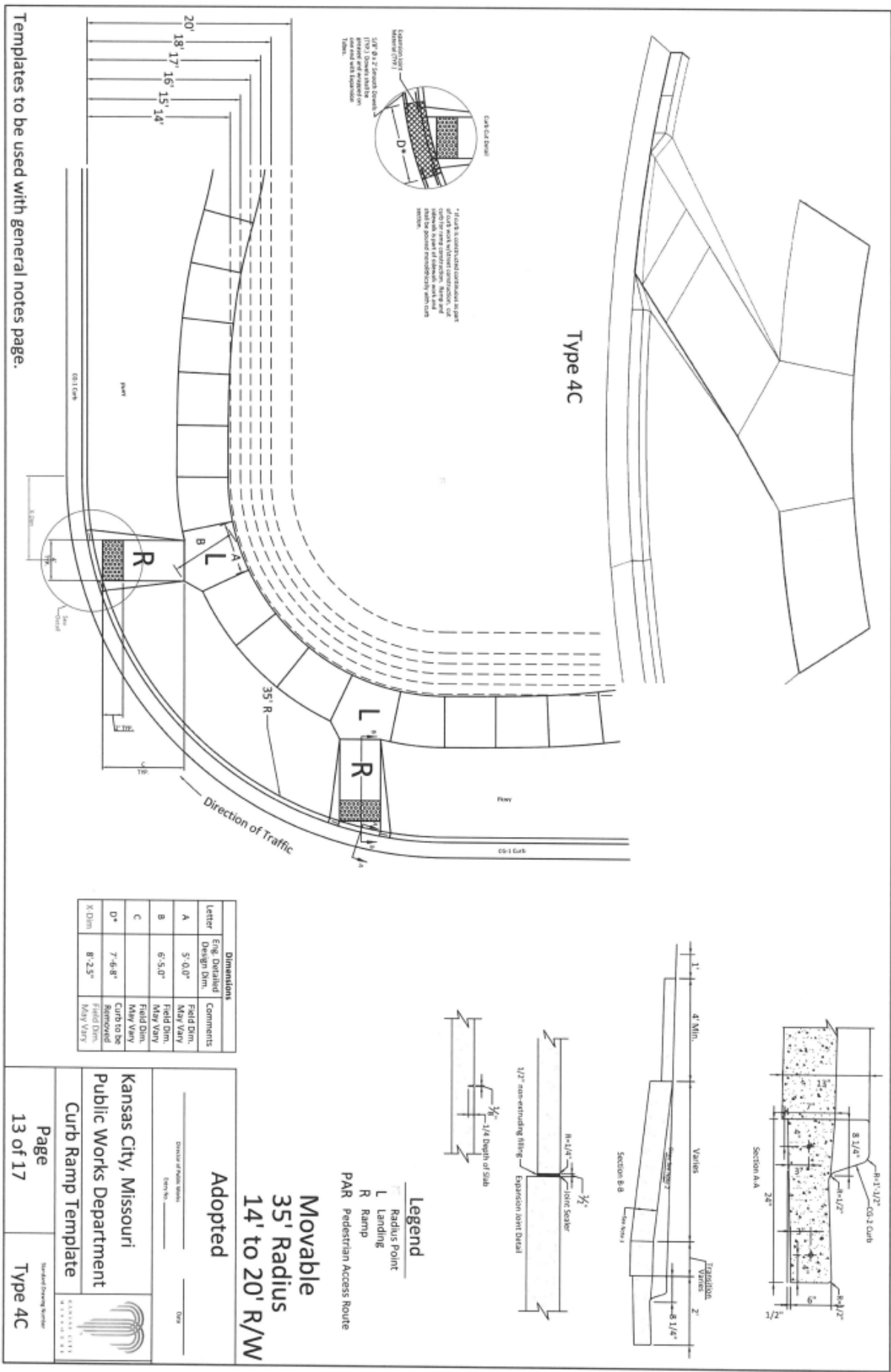

Templates to be used with general notes page.

Letter	Eng. Detailed Design Dim.	Comments
A	5'-0.0"	Field Dim. May Vary
B	6'-5.0"	Field Dim. May Vary
C		Field Dim. May Vary
D+	7'-6.8"	Curb to be Removed Field Dim. May Vary
X Dim	8'-2.5"	Field Dim. May Vary

Adopted

Movable 35' Radius 14' to 20' R/W

Kansas City, Missouri
Public Works Department

Curb Ramp Template

Page 13 of 17

Type 4C

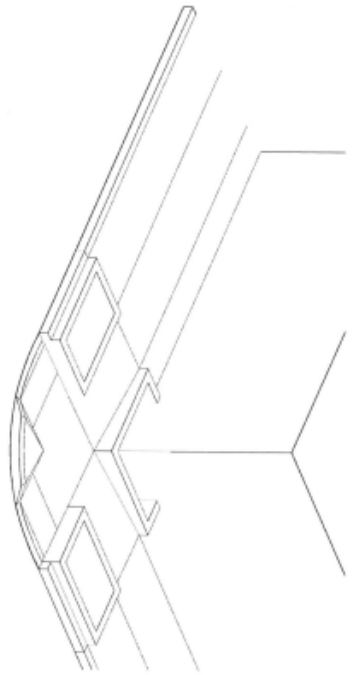

Type 5A

Expansion Joint
Material (TRP)

5/8" Ø x 2' Smooth Dowels
(TRP). Dowels shall be
greased and wrapped on
one end with Expansion
Tubes.

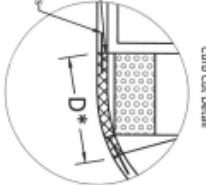

* If curb is constructed continuous as part
of curb work w/street construction, cut
curb for ramp construction. Ramp and
sidewalk is part of sidewalk work and
shall be poured monolithically with curb
section.

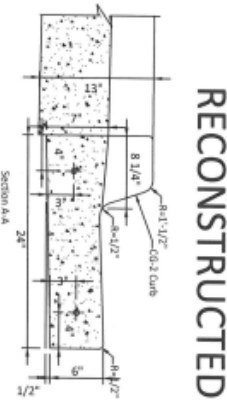
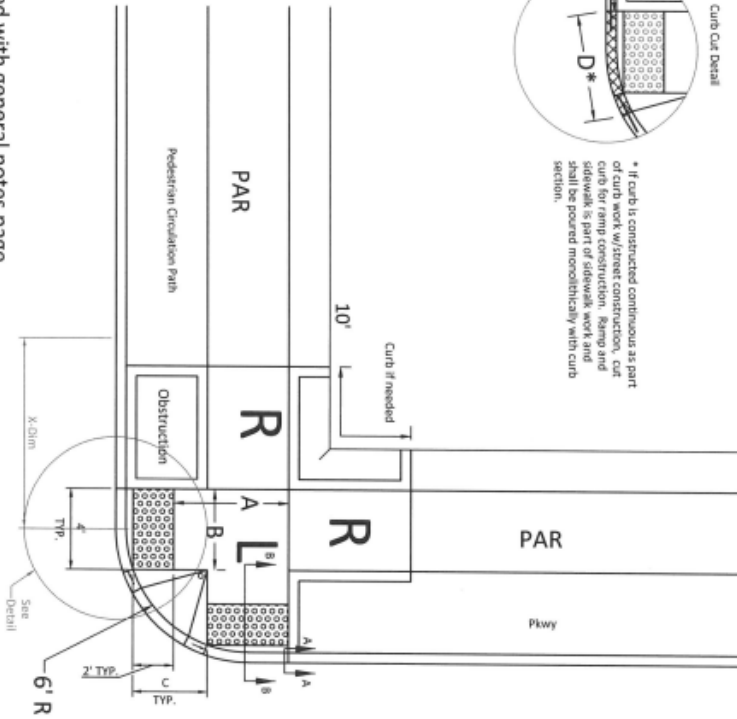

RECONSTRUCTED

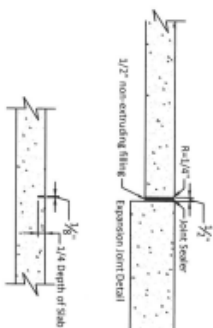
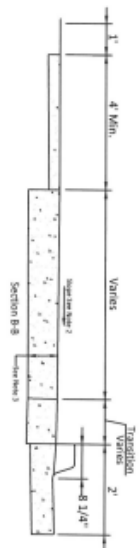

- Legend**
- ↖ Radius Point
 - L Landing
 - R Ramp
 - PAR Pedestrian Access Route

Letter	Dimensions	Comments
A	5'-8.0"	FIELD DIM. MAY VARY
B	4'-0.0"	FIELD DIM. MAY VARY
C	5'-2.6"	FIELD DIM. MAY VARY
D*	9'-4.30"	CURB TO BE RECONSTRUCTED. MAY VARY
X-Dim		

Adopted

Director of Public Works _____

City Engineer _____

Kansas City, Missouri

Public Works Department

Curb Ramp Template

Page 14 of 17

Reconstructed Type 5A

Templates to be used with general notes page.

RECONSTRUCTED

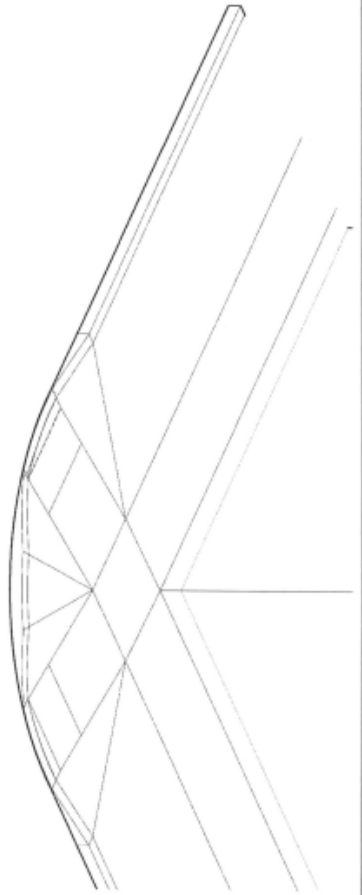

Type 5B

* If curb is constructed continuous as part of curb work w/ street construction, cut curb for ramp construction. Ramp and sidewalk is part of sidewalk work and shall be poured monolithically with curb section.

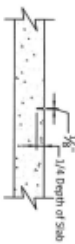
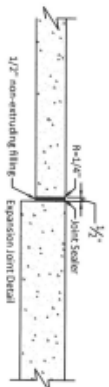
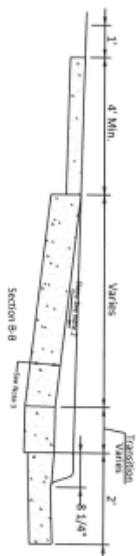
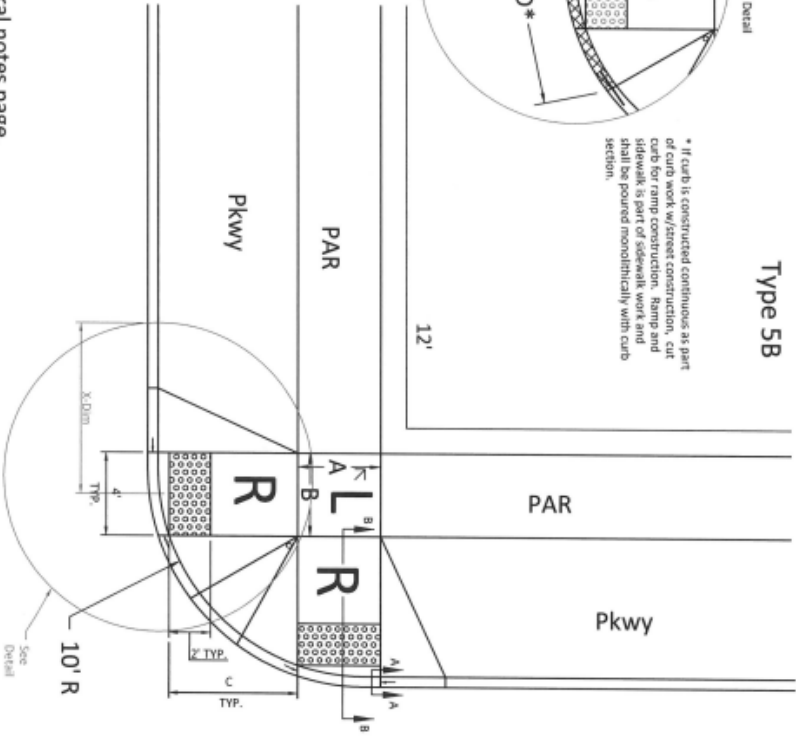
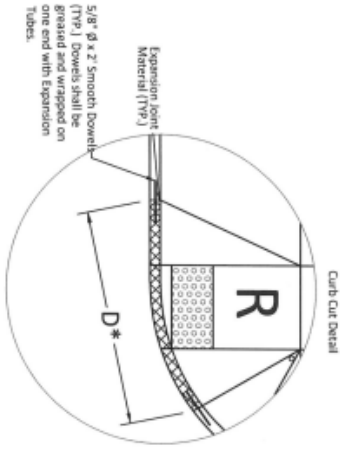

Legend

- ⊣ Radius Point
- L Landing
- R Ramp
- PAR Pedestrian Access Route

Letter	Engr. Detailed Design Dim.	Comments
A	4' min.	Field Dim. May Vary
B	4' min.	Field Dim. May Vary
C		Field Dim. May Vary
D*	10'-4.5"	Curb to be removed
X-Dim	8'-3.50"	Field Dim. May Vary

Adopted

Director of Public Works _____ Date _____

City No. _____

Kansas City, Missouri
Public Works Department

Curb Ramp Template

Page 15 of 17

Reconstructed Type 5B

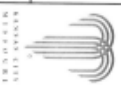

Templates to be used with general notes page.

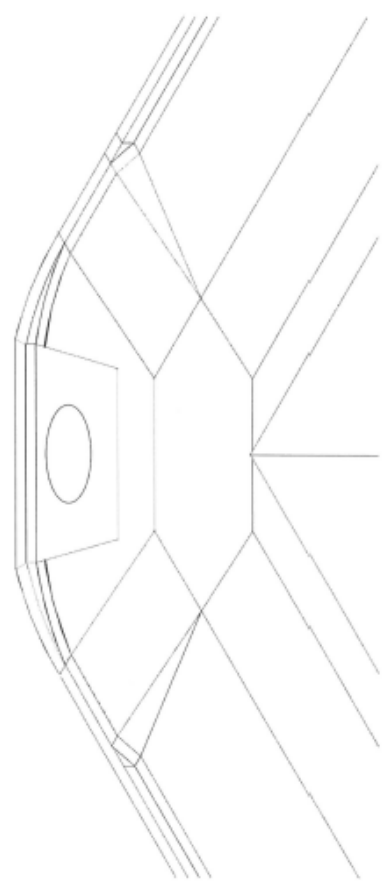

Type 5C

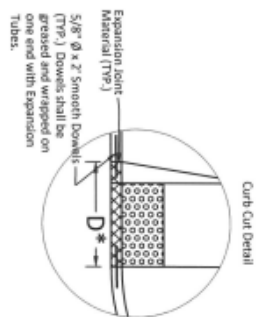

* If curb is constructed continuous as part of curb work w/street construction, cut curb for ramp construction. Ramp and sidewalk is part of sidewalk work and shall be poured monolithically with curb section.

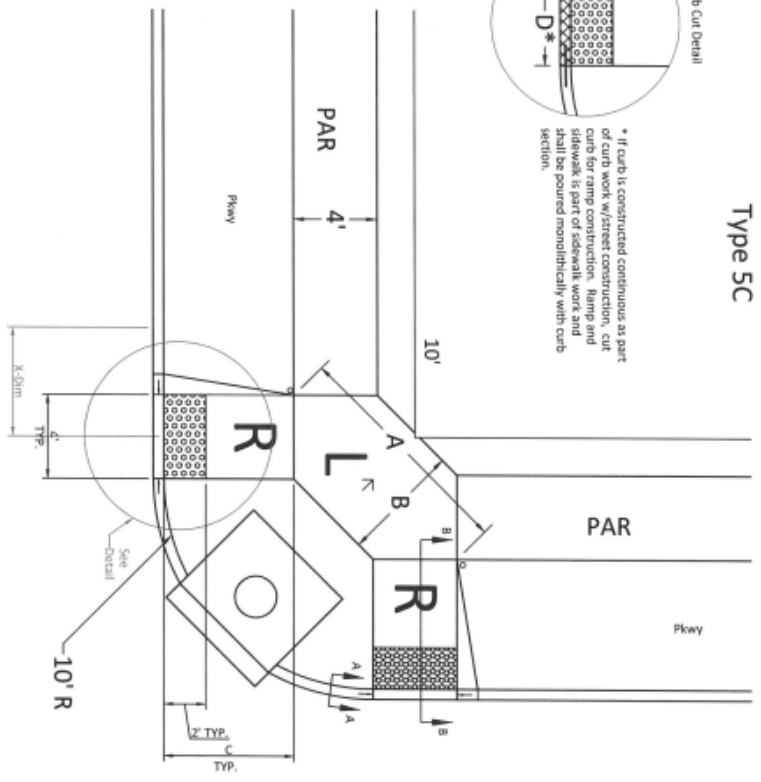

RECONSTRUCTED

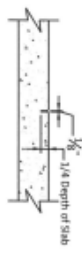
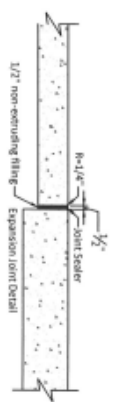
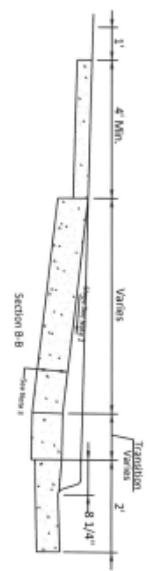
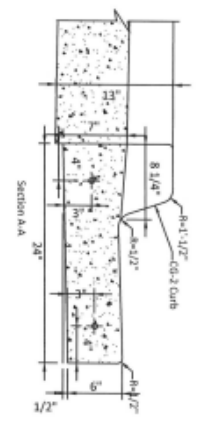

- Legend**
- ↖ Radius Point
 - L Landing
 - R Ramp
 - PAR Pedestrian Access Route

Letter	Dimensions Fig. Detailed Design Dim.	Comments
A	11'-0.0"	Field Dim. May Vary
B	5'-8.0"	Field Dim. May Vary
C	May Vary	Field Dim. May Vary
D*	5'-0.0"	Curb to be Removed
X Dim	5'-3.0"	Field Dim. May Vary

Adopted

 Director of Public Works
 Title

 Title

Kansas City, Missouri
Public Works Department

Curb Ramp Template

Page 16 of 17
 Reconstructed Type 5C

Templates to be used with general notes page.

RECONSTRUCTED

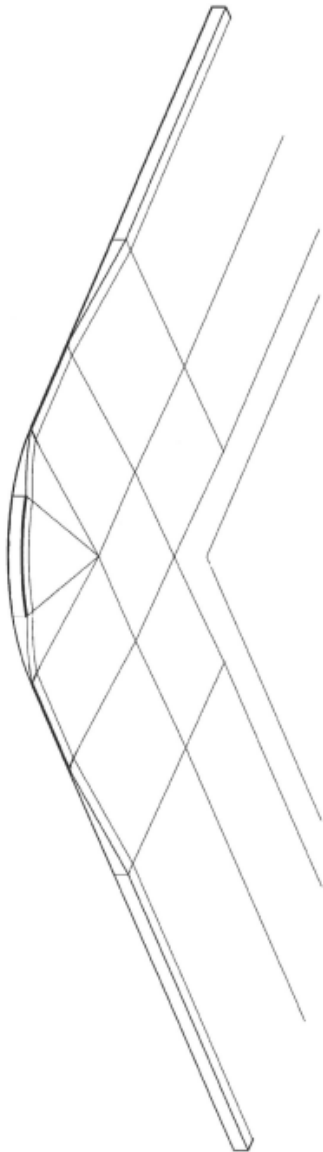

Curb cut Detail

Type 5D

* If curb is constructed continuous as part of curb work w/street construction, cut curb for ramp construction. Ramp and sidewalk is part of sidewalk work and shall be poured monolithically with curb section.

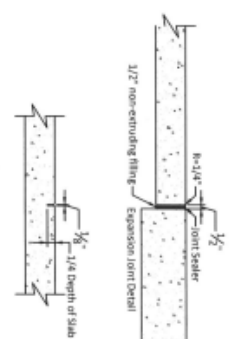
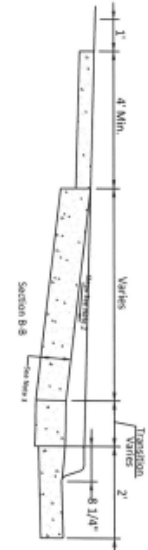
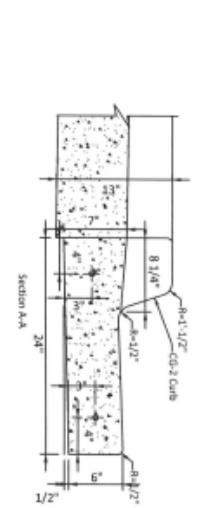
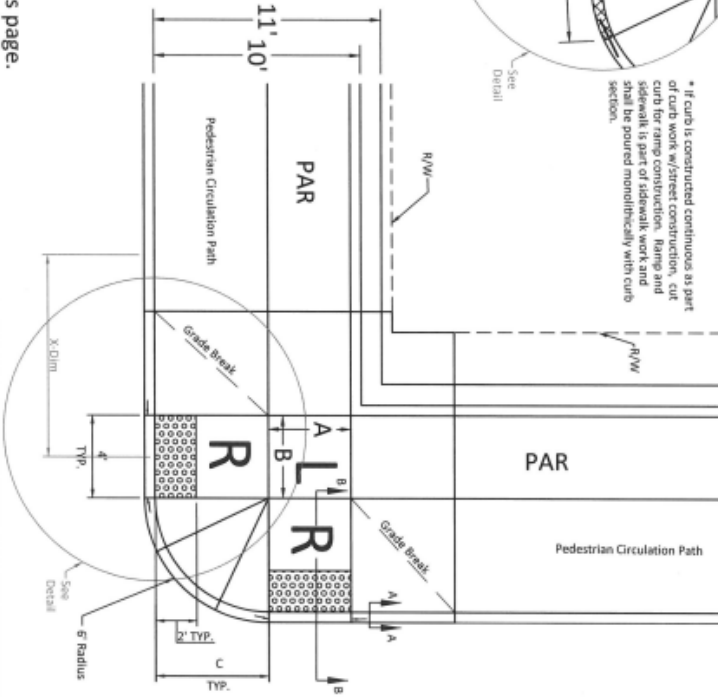
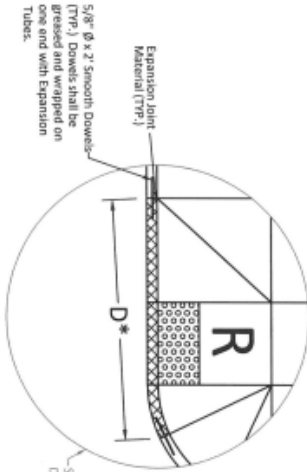

- Legend**
- ↖ Radius Point
 - L Landing
 - R Ramp
 - PAR Pedestrian Access Route

Letter	Dimensions	Eng. Detailed Design Dim.	Comments
A	4' min.	4' min.	Field Dim. May Vary
B	4' min.	4' min.	Field Dim. May Vary
C	11'-7.2"	11'-7.2"	Field Dim. May Vary
D*	9'-8.80"	9'-8.80"	Field Dim. May Vary

Adopted

Division of Public Safety
 Date: _____
 City: _____

Kansas City, Missouri
Public Works Department

Curb Ramp Template

Page 17 of 17

Reconstructed Type 5D

Templates to be used with general notes page.

D. Reinforced Sidewalks and Driveways:

1. **General:** In addition to meeting the requirements for sidewalks and driveways as outlined above, reinforced sidewalk and driveways shall also conform to Section 2301 of the Kansas City “Standard Specifications and Design Criteria.” All sidewalks and driveways reconstructed along streets under the jurisdiction of the Parks and Recreation Department shall be in accordance with the plans and specifications of that department. Reinforcing shall be 6 x 6 - W2.9 x W2.9 welded steel wire fabric. Work on Parks and Recreation Department streets shall also require a separate permit from that Department.
2. **Payment:** Payment will be made at the contract unit bid prices per square foot for the applicable type of sidewalk or driveway as listed in section 00412 – Unit Prices.

E. Concrete Stamping and Coloring:

1. **General:** The Contractor shall match as closely as possible the color and/or pattern of any stamped and/or colored concrete.
2. **Payment:** Payment will be made at the contract unit bid price for “Concrete Stamping and/or Coloring Markup” as listed in Section 00412 – Unit Prices.

End of Section

SECTION 02777 - CONCRETE STEPS

- A. General:** This item shall consist of removing any existing steps and constructing steps at locations shown on the plans or at locations designated by the Engineer. Section 00412 – Unit Prices includes an estimated amount of "Concrete Steps". The actual amount may be greater, less, or none at all.

The Contractor shall remove any existing steps as required by the Engineer and shall construct the new concrete steps and handrails (where applicable) to match existing steps unless otherwise directed by CITY.

Where the steps abuts other concrete or permanent structures, expansion joints shall be constructed and caulked as specified in Section 02775 of this Project Manual and as shown on the standard drawing.

Concrete steps shall be measured to the nearest square foot. This measurement shall be along the front face of the riser and the top of the tread.

CONTRACTOR shall dispose of all remaining materials on site.

- B. Payment:** Payment shall be made at the contract unit bid price per square foot for "Concrete Steps", as listed in Section 00412 – Unit Prices and as stated in Section 01260 - Measurement and Payment.

End of Section

SECTION 02781 - BRICK AND STONE SIDEWALKS, BORDERS, AND DRIVEWAYS

A. Brick and Stone Set in Mortar

1. **General:** Where it is determined by CITY that existing brick or stone work shall be replaced, existing material shall be removed to full depth and subgrade shall be prepared to match existing brick or stone. A base of four inch Portland Cement Concrete conforming to MCIB Mix No. WA610-1-4 shall be placed prior to the installation of the brick or stone surface. Concrete base shall be rough finished to provide a bonding surface for mortar setting bed. Concrete which is partially or completely set shall be cleaned and wetted prior to placing of mortar. Brick pavers or stones shall be placed in 1/2" mortar setting bed and laid to match existing pattern. CONTRACTOR shall dispose of all excess materials.

Section 00412 – Unit Prices includes an estimated amount of "Brick/Stone Walk or Border". The actual amount may be greater, less, or none at all.

B. Brick and Stone Set in Sand

1. **General:** Where it is shown on the plans or determined by the CITY that the existing concrete paver sidewalks or driveways shall be replaced; the contractor shall remove and store the existing concrete pavers. The contractor shall document the patterns, locations and design of the existing sidewalk or driveway prior to disturbing the pavers.
2. **Subgrade:** The sub-grade and sub-base shall be prepared and constructed as shown in the detail at the end of this section.
3. **Bedding:** Bedding and joint sand shall be clean, non-plastic, and free from deleterious or foreign matter. The sand shall be natural or manufactured from crushed rock. Limestone screenings or stone dust shall not be used. Bedding sand shall conform to the grading requirements of ASTM C 33 and Joint sand shall conform to ASTM C144 or as recommended by the manufacturer.
The contractor shall spread the sand evenly over the base course and screed to a nominal 1 inch thickness, not exceeding 1-1/2 inch thickness. The screeded sand should not be disturbed. The contractor shall place sufficient sand to stay ahead of the laid pavers. Do not use the bedding sand to fill depressions in the base surface.
4. **Installation:** The contractor shall relay the concrete pavers at the grade specified by the engineer. The contractor shall reuse the undamaged

concrete pavers in the reconstruction of the sidewalk or driveway. If additional concrete pavers are required to complete the work, the contractor shall obtain materials that match the existing material. Any new concrete pavers required to complete the sidewalk or driveway shall meet the requirements of ASTM C936 and shall be approved by the Engineer prior to their incorporation into the work. The contractor shall also match the pattern and shape of the existing sidewalk or driveway. The contractor shall ensure that pavers are free of foreign materials before installation. The joints between the pavers shall match the existing pavers. The contractor shall fill gaps at the edges of the paved area with cut pavers or edge units. Any pavers to be cut shall be cut with a masonry saw. The contractor shall use a low amplitude, high frequency plate vibrator to vibrate the pavers into the sand. The contractor shall vibrate the pavers, sweeping dry joint sand into the joints and vibrating until they are full. In addition the concrete pavers are to be installed according to the manufacturer's recommendations and to the satisfaction of the Engineer and the property owner.

C. Brick and Stone Sidewalks and Driveways

1. **Materials:** Brick pavers shall conform to ASTM C902-79a, Class SX, Type 1, or match, existing. Stone shall match existing as approved by the Engineer. Mortar shall conform to ASTM C270-82, Cement Lime Type M. Where possible, undamaged bricks or stone shall be reused.
2. **Joints:** Where brick or stone sidewalk abuts other concrete or permanent structures, expansion joints shall be constructed and caulked as specified for "Sidewalks" in Section 02775 of this Project Manual.

D. Brick Border Resetting:

1. **General:** Where it is determined by the Engineer that existing brick or stone work shall be replaced, existing material shall be removed to full depth and subgrade shall be prepared to match the existing brick or stone. A base of four inch Portland Cement Concrete shall be placed prior to the installation of the brick or stone surface. Concrete base shall be rough finished to provide a bonding surface for mortar setting bed. Concrete which is partially or completely set shall be cleaned and wetted prior to placing of mortar. Brick pavers or stones shall be placed in 1/2" mortar setting bed and laid to match existing pattern.
2. **Materials:** Brick pavers shall conform to ASTM C902-79a, Class SX, Type I, or match existing. Stones shall match existing as approved by the Engineer. Mortar shall conform to ASTM C270-82, Cement Lime Type M. Where possible, undamaged bricks or stones shall be reused.

3. **Joints:** Where brick abuts concrete or permanent structures, expansion joints shall be constructed and caulked as specified for "Sidewalks" and "Driveways" in Section 02775 of this Project Manual.

E. Payment:

Payment shall be made at the contract unit bid price per square foot for "Brick/Stone Walk or Border" as listed in Section 00412 – Unit Prices and as stated in Section 01260 - Measurement and Payment.

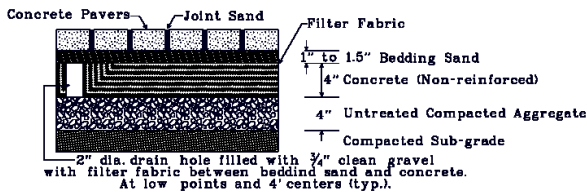

End of Section

Typical Detail

SECTION 02785 - TRAFFIC CONTROL

A. General Requirements:

1. The Contractor shall take any and all proper precautions to guard against injury to persons or damage to property until final acceptance of the work by the CITY. These precautions should include, but not be limited to, protection of vehicular and pedestrian traffic from injury or damage due to open excavations by the proper placement of appropriate safety devices. The Contractor shall maintain safety devices and their proper placement throughout the needed period. Construction practices should be followed that will eliminate all safety hazards as quickly as possible or practicable.
2. The Contractor shall provide all barricades, cones, drums, construction warning signs, flagmen and incidental devices to protect, warn, and guide vehicular and pedestrian traffic, and to protect his personnel and equipment on the job site. During all phases of construction, the Contractor shall display the required signs. Any traffic control device not in use shall be covered, removed or turned away from view of oncoming traffic. Whenever the work area changes, all construction warning signs and traffic channelization devices shall be made current in both legend and function.
3. All traffic control devices shall conform to the "Manual on Uniform Traffic Control Devices for Streets and Highways", most recent edition, and any current revisions. No substitutions for the devices required by the above referenced manual or changes in the methods of traffic control as outlined herein will be allowed without the written approval of CITY.
4. The Contractor's representative on this project will make daily inspections of the traffic control devices installed as part of this contract and maintain records of any maintenance required and the date on which it was completed. These records will be maintained for the duration of the project and be incorporated as part of the final records. It shall be the Contractor's responsibility to maintain its traffic control devices in proper working condition and placement at all times. The Contractor shall promptly correct any deficiencies in traffic control.
5. The Contractor shall be required to maintain access to all properties served by streets affected by the construction work, unless otherwise directed by CITY.
6. Construction work that requires sidewalk closures or temporary restriction of on-street parking will be permitted along one side of alternating blocks on one side of the street at a time, or in any other combination, provided that in any one block

both sidewalks or curb parking are not closed or restricted at the same time. A maximum of two (2) blocks shall be under construction at any one time.

B. Construction: Construction will be permitted along one side of alternating blocks, one side of the street at a time, or any other combination, provided that both sides in any one block are not under construction at the same time.

C. Emergency No Parking Signs:

1. When it is necessary to eliminate parking on a part of a street to facilitate construction work, the Contractor shall, subject to the approval by CITY, post "**EMERGENCY NO PARKING, 7 a.m. to 6 p.m.**" or "**EMERGENCY NO PARKING, DAY OR NIGHT**" signs on the side of the street where parking is to be eliminated. The signs must read as shown herein and must be on aluminum or plywood panels. **Paper or cardboard signs will not be allowed.** These signs must be installed a minimum of 18 hours and a maximum of 48 hours in advance of the time the Contractor plans to begin work. The Contractor must contact the inspector as soon as the signs are installed. The inspector will contact the Street and Traffic Division Dispatcher ((816) 513-2627 from 8 a.m. to 5 p.m., Monday through Friday) as soon as the signs are installed so that a temporary regulation can be written by the Streets and Traffic Division and the Kansas City, Missouri, Police Department can be notified. The signs cannot be enforced without this notification from the City. The notification to the City must be made by 12 noon for enforcement to be effective the following day.
2. The signs are to be installed on either steel drive posts or existing utility poles at a height of five (5) feet to the bottom of the sign. The signs are to be installed at the beginning and end of each block and at 150-foot maximum intervals in between. If there are existing parking restriction signs of a lesser degree of restriction, the Contractor shall install the **EMERGENCY NO PARKING** signs as outlined above and shall cover the existing signs with the **EMERGENCY NO PARKING** sign or some type of permanent cover (**paper and tape will not be accepted**). The Contractor shall immediately remove all signs and covers as soon as work in a block has been completed. If it becomes apparent, for any reason, that work will cease for more than 72 hours, the same signs and covers shall be removed and must be reinstalled subject to the minimum 18 hours advance notice before work can proceed. If work does not begin within 48 hours after the signs are posted, the same procedure must be followed. Failure by the Contractor to abide by all the provisions concerning "**EMERGENCY NO PARKING**" signs, will result in the cancellation of the permit.

D. Sidewalk Closed Signs: The Contractor shall utilize sidewalk closed signs as shown on herein to direct pedestrians to walk along the opposite side of the street while the sidewalk is closed.

E. Specific Requirement:

1. The contractor may close only one curb lane of the roadway at a time, maintaining two-way traffic in the other half of the roadway or using **FLAGGERS** to direct traffic.
2. On the streets where there is restricted parking during rush hours, the contractor shall be prohibited from working on the side of the street where restrictions apply during those hours. For example, if the northbound lane of a street has **No Parking from 7:00 a.m. to 9:00 a.m.**, the Contractor shall be prohibited from working in that lane during those hours. On the streets where there is **No Parking Anytime**, the Contractor shall obtain approval for work hours ahead of time from CITY, so they may work anytime.
3. During non-working hours, all roadways shall be opened to normal operating conditions. No construction related equipment shall be on the roadway. Barrels with Type C warning lights shall be placed adjacent to the work area. All of the construction signs except the **ROAD CONSTRUCTION AHEAD** signs shall be covered or turned away from traffic.
4. Access to adjacent properties shall be maintained at all times.
5. Emergency No Parking 7:00 a.m. to 6:00 p.m. may be required for this construction.

F. Payment: All costs pertaining thereto shall be included in the contract unit price for traffic control as listed in Section 00412 – Unit Prices and as stated in Section 01260 - Measurement and Payment.

End of Section

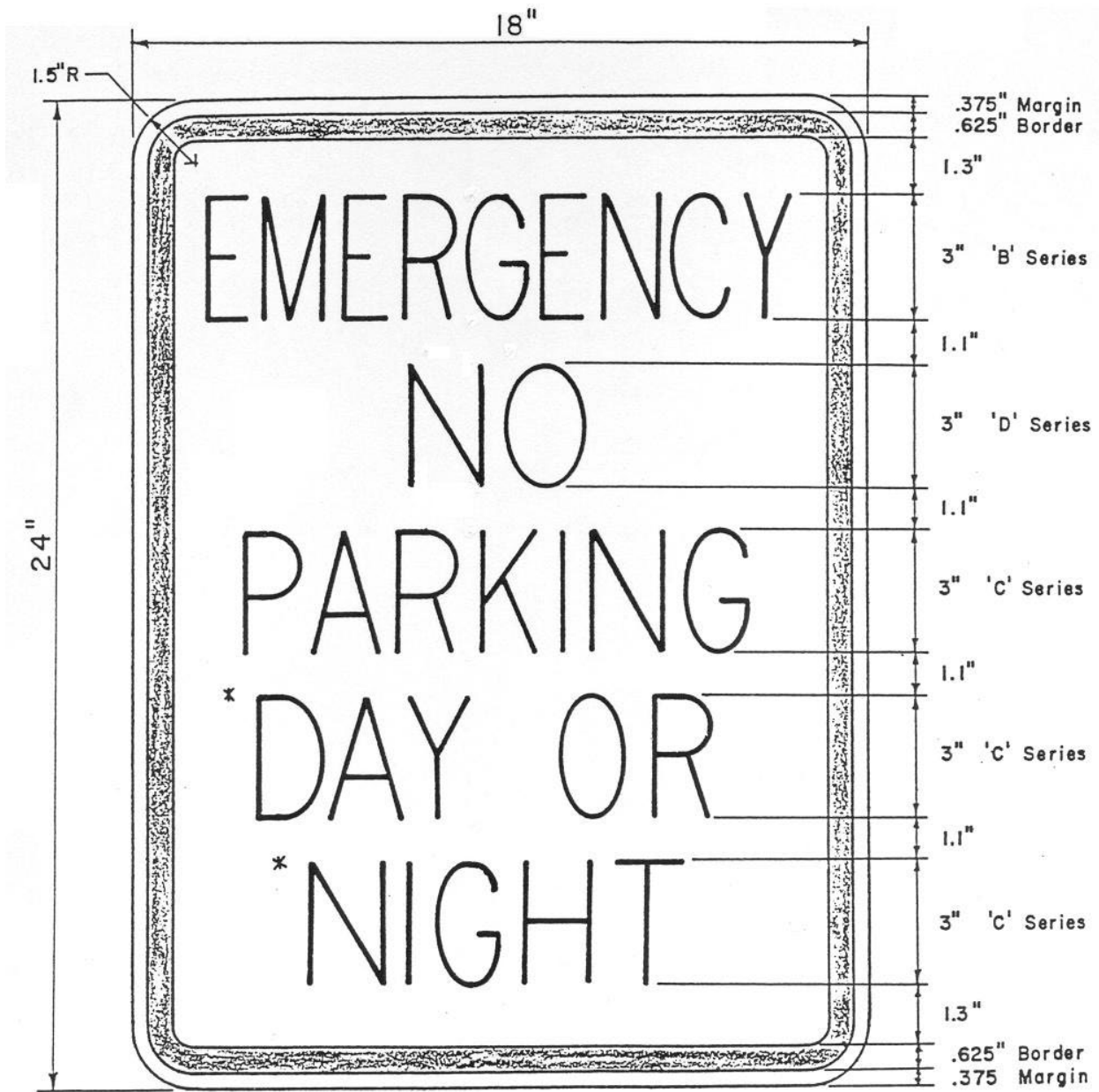

COLOR: Letters and Border - Red
 Background - Silver (reflective)

* ALTERNATE FOR
 LINES 4 & 5

7AM TO
 6PM

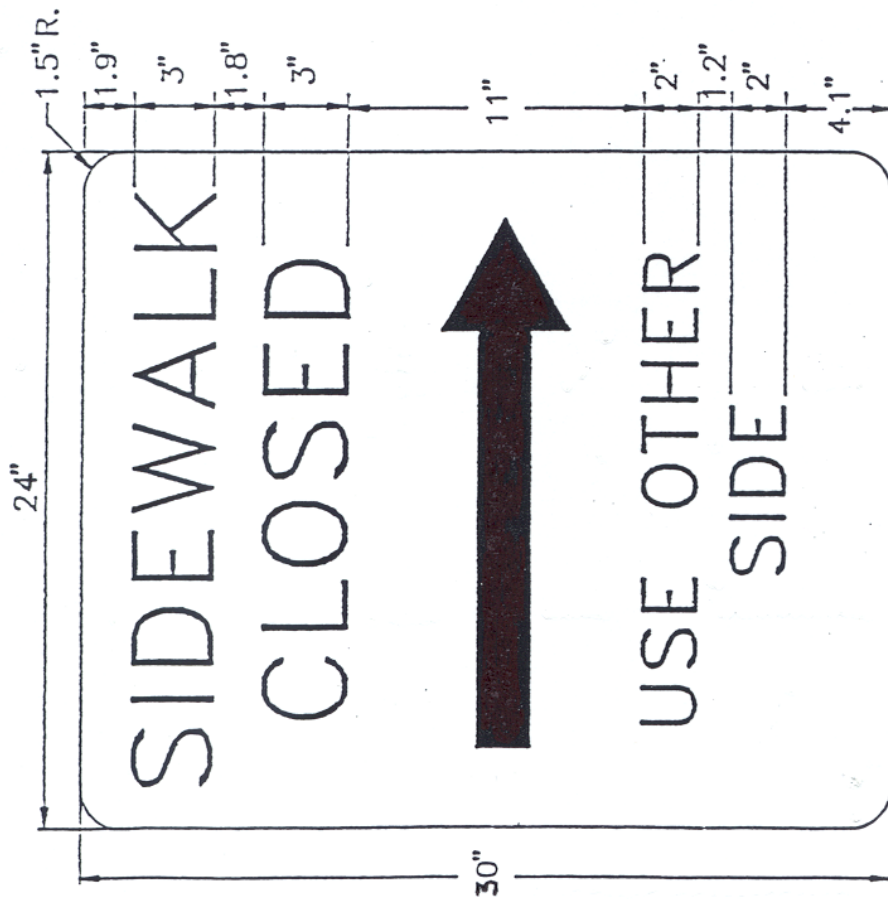

U-R

COLOR: Letters and Arrows - Black
Background - White (reflective)



U-L

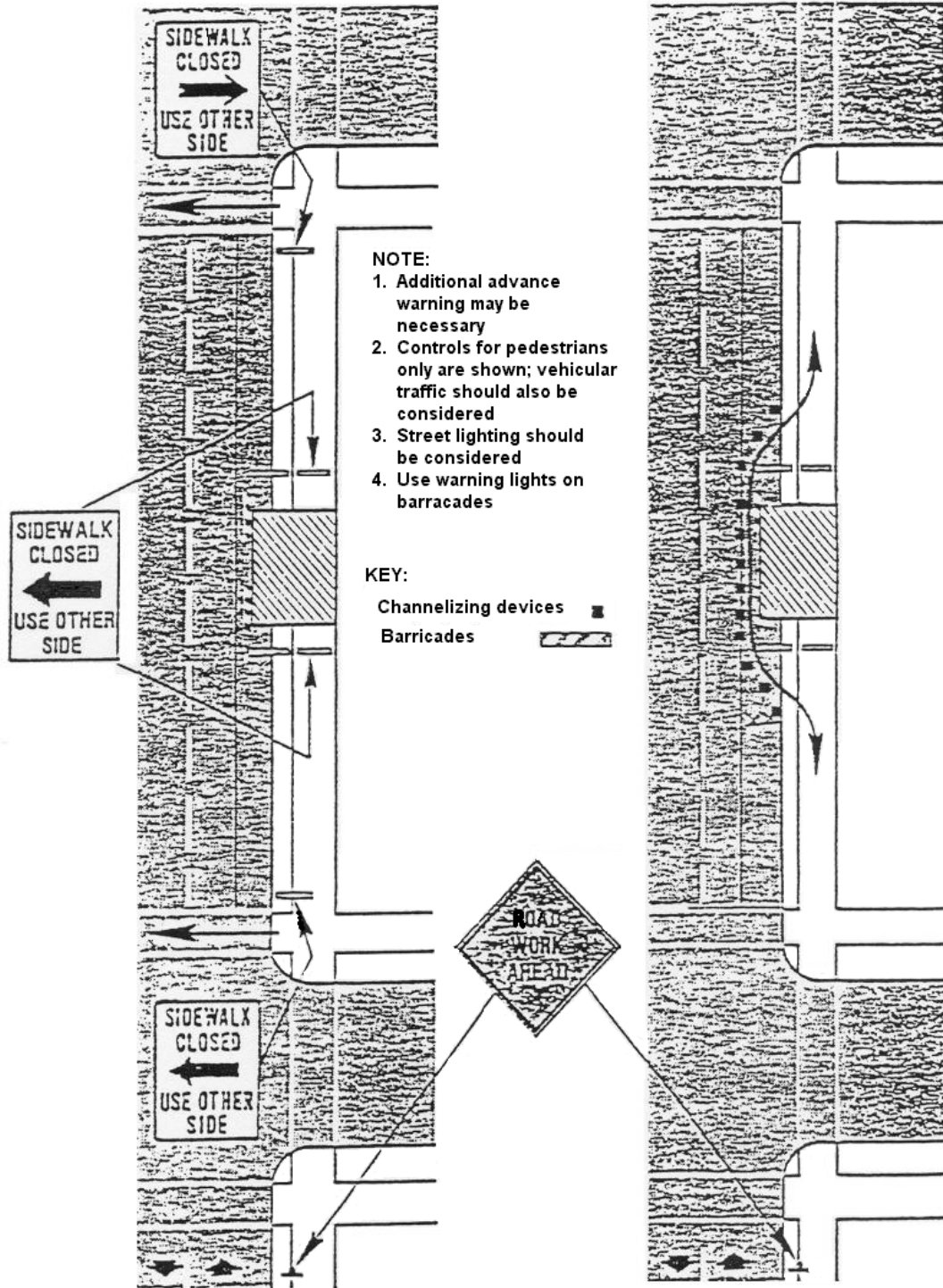
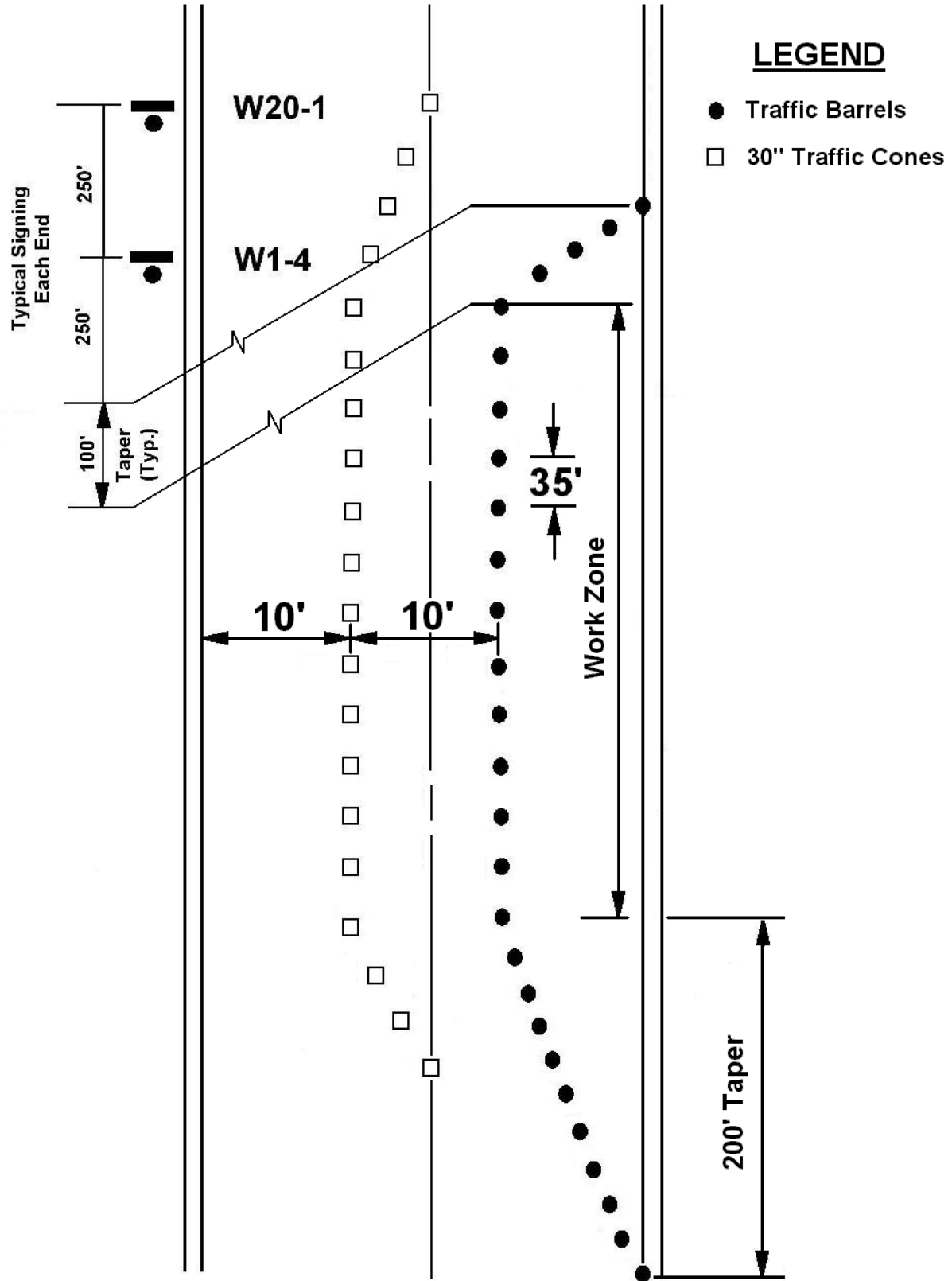
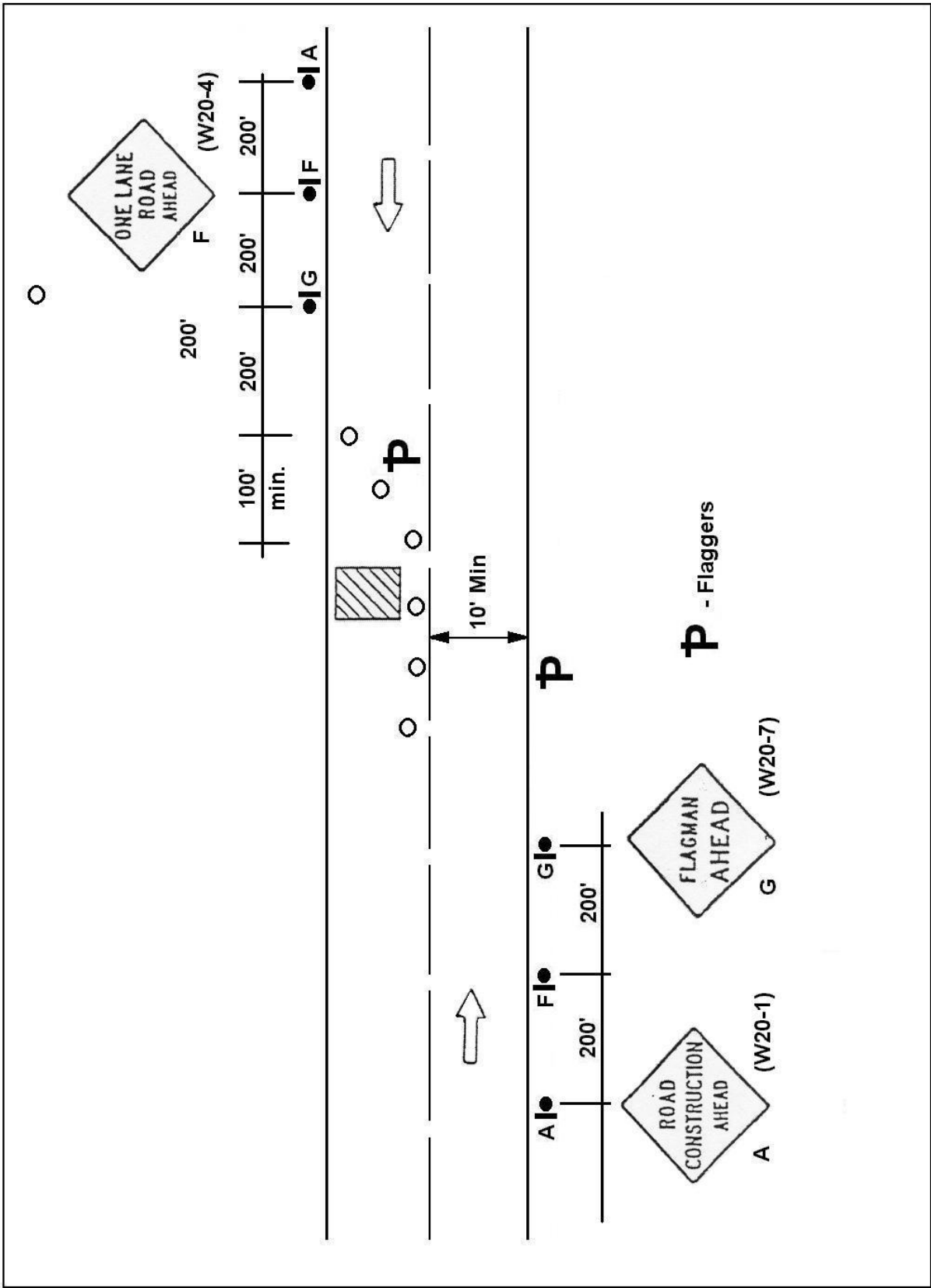
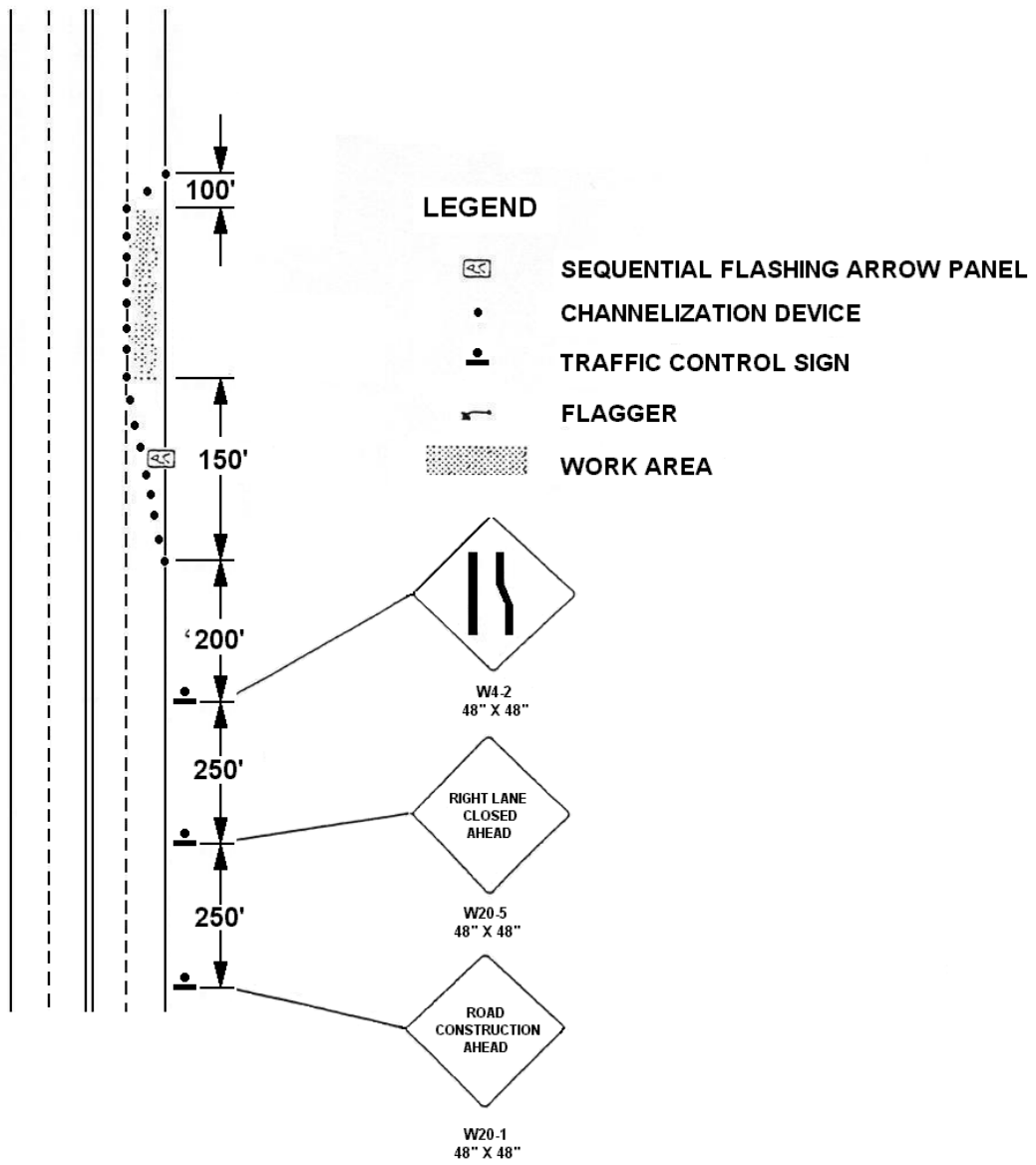

Figure 6-24 Typical Applications - Two Methods for Controlling Pedesrian Traffic by Either Directing Pedestrians to Another Route or Providing a Walkway







TYPICAL RIGHT LANE CLOSURE

BLACK MESSAGE ON ORANGE REFLECTIVE BACKGROUND - SIGNS A THRU K MIN. SIZE (A THRU I) 36" X 36"

MIN. SIZE (J) 24" X 30"

BLACK MESSAGE ON WHITE REFLECTIVE BACKGROUND - SIGNS M THRU U

NOTE: DESIGNATE DISTANCE FROM SIGN TO CLOSURE IN BLANK SPACE (MILES OR FEET).

MIN. SIZE (M) 30" X 48"

MIN. SIZE (N & P) 30" X 60"

MIN. SIZE (P) (R11-3)

MIN. SIZE (Q) 18" X 24"

MIN. SIZE (T & U) 24" X 30"

MIN. SIZE (U) 18" X 24"

MIN. SIZE (U-R) 18" X 24"

MIN. SIZE (U-L) 18" X 24"

MIN. SIZE (U) 18" X 24"

ALL SIGNS MUST CONFORM TO THE MANUAL ON UNIFORM TRAFFIC CONTROL DEVICES UNLESS OTHERWISE NOTED

CHANNELIZATION DRUM DETAIL

ORANGE	30 GAL.
WHITE	55 GAL.

30 - 55 GAL. DRUM WITH 4" - 6" WHITE AND ORANGE HORIZONTAL, REFLECTORIZED STRIPES - MIN. 2 WHITE AND 2 ORANGE PER DRUM. THESE MUST BE EQUIPPED WITH ONE, TYPE "C" STEADY-BURN LIGHT EACH, FOR NIGHT USE.

STANDARD LEGEND

- O - INDICATES 36" ORANGE PLASTIC CONE
- - INDICATES STEEL DRUM (SEE DETAIL)
- ⊙ - INDICATES DRUM WITH SIGN AND STANDARD

KANSAS CITY, MISSOURI TRANSPORTATION DEPARTMENT

STANDARD SIGNS FOR TRAFFIC MAINTENANCE DURING CONSTRUCTION

APPROVED: *[Signature]* 5/1/04

NO SCALE 8/78 K.F. A-387

SECTION 02790 - WATER VALVE ADJUSTMENT

- A.** All water valve covers shall be adjusted to the new elevation of the street surface resulting from repair of the street. Section 00412 – Unit Prices includes an estimated amount of "Water Valve Adjustment". The actual amount may be greater, less, or none at all.
- B.** Adjustment in the elevation of these valve covers shall be made before the final surface course is placed and after any binder, leveling, wedge or base course is placed.
- C.** Water valve cover adjusting rings will be furnished by the City, and will be available for the CONTRACTOR to pick up at the Water Department Maintenance Facility located at 18th and Prospect. The adjusting rings are set in position by removing the valve cover lid, and then inserting the adjusting ring. No mechanical anchors or adhesive will be required.
- D.** Payment for this item shall be made at the contract unit bid price for "Water Valve Adjustment" per each, as listed in Section 00412 – Unit Prices and as stated in Section 01260 - Measurement and Payment.

End of Section

**SECTION 02795 - SEWER MANHOLE ADJUSTMENT RING AND ADJUSTABLE
SEWER MANHOLE RING AND COVER**

- A.** All sewer manhole covers shall be adjusted to the elevation of the street surface resulting from repair of the street. Section 00412 – Unit Prices includes an estimated amount of "Sewer Manhole Adjustment" and "Adjustable Sewer Manhole Ring and Cover". The actual amount may be greater, less, or none at all.
- B.** Sewer manhole cover adjusting rings will be furnished by the CONTRACTOR, and approved for use by CITY.
- C.** No adjustment rings shall be used within the Downtown Loop unless authorized by the CITY.
- E.** Adjustable sewer manhole ring and cover will be furnished by the CONTRACTOR. The adjustable manhole assemblies shall be installed according to the manufacturer's recommendation. The new manhole assembly shall be set at $\frac{3}{4}$ " to allow future lowering and raising of the manhole.
- F.** Subsurface conditions that require additional work beyond manufacturer's recommendations for installation of adjustable manhole assemblies shall be included in the Unit Bid Price.
- G.** Payment shall be made at the Contract Unit Price as listed in Section 00412 – Unit Prices and as stated in Section 01260 - Measurement and Payment. Such payment and price shall constitute full compensation for all labor, materials, and equipment necessary to complete the item. The actual amount may be greater, less or none at all.

End of Section

SECTION 02930 - SEEDING

PART 1 GENERAL

A. Section Description

1. This section provides for areas to be restored with seeding materials.

B. Related Sections

1. Section 02931 - Sodding
2. Section 02070 – Fill Dirt and Topsoil

C. References

1. FS O-F-241 - Fertilizers, Mixed, Commercial.

D. Procedures

1. Seeding areas: All areas disturbed by construction operations including areas of cut and fill, trenching, temporary roads, and temporary staging or storage areas shall be seeded unless otherwise specified.
2. All seeding shall be performed by the hydroseeding/hydromulching method unless otherwise specifically approved by CITY.
3. Prior to application, roughen embankment and fill areas by rolling with a crimping or punching type roller or by hand raking with a bow rake.
4. CONTRACTOR shall incorporate appropriate anti-erosion measures as needed on steep slopes.

E. Quality Assurance

1. Materials shall comply with regulatory agencies for fertilizer and herbicide composition and shall not produce an undesirable odor.
2. Seed and Fertilizer shall be labeled in accordance with U.S. Department of Agriculture Rules and Regulations under the Federal Seed Act and State seed laws. Seed shall be furnished in sealed standard containers of the vendor. Each seed container shall bear the name, trade name, or trade mark, and a warranty of the producer and a certificate of the percentage of the purity and germination of each kind of seed specified. Seed which has become wet, moldy, or otherwise damaged in transit or in storage will not be acceptable
3. CITY reserves the right to take and analyze samples of materials for conformity to the specifications at any time. Rejected materials shall be removed immediately from the site at CONTRACTOR's expense. CONTRACTOR shall pay the cost of testing replacement materials.
4. All seeding work shall be performed by a contractor having demonstrated experience in seeding on projects of similar size. The work shall be prepared by experienced personnel who are familiar with the required work and who are under the supervision of a qualified foreman at all times when the work is in progress.

SECTION 02930 - SEEDING

5. The CONTRACTOR shall have access to equipment including a hydroseeder/hydromulcher, fertilizer spreader, and straight serrated disk for crimping mulch into the soil.
6. The appearance of completed grass repairs shall be equal to or better than the appearance of the grass on the remainder of the property where the Work is performed.
7. Warranty: CONTRACTOR shall correct grass that that did not grow according to the CITY's satisfaction within the warranty period where it was not the fault of lack of maintenance by the resident or a result of subsequent damage by other parties. This includes seed that was planted in the Winter but did not grow in the Spring.

PART 2 PRODUCTS

A. Topsoil for Repairs

1. Topsoil for repairs shall conform to Section 02070 – Fill Dirt and Topsoil. Final surfaces shall match adjacent existing areas, be non-ponding with a minimum 1% slope to drain where possible, and be smooth and even. Excess soil, debris or other materials shall be disposed of by CONTRACTOR at CONTRACTOR's expense.

B. Mulch

1. Wood Cellulose Fiber Mulch:

Prepared from virgin wood fibers containing no substance that might inhibit germination or growth of grass seed. Mulch shall be dyed an appropriate color to allow visual maintenance of its application and shall contain a tacking agent. The wood cellulose fibers shall be evenly dispersed and suspended when agitated in water. When sprayed uniformly on the surface of the soil, the fiber shall form a blotter-like ground cover that readily absorbs water and allows infiltration to the underlying soil. Weight specifications from suppliers, and for all applications, shall refer only to air dry weight of the fiber, at a standard equivalent of 10 percent nominal moisture content.

2. Other mulch ingredients:

CONTRACTOR may incorporate other mulch additives if they will improve the quality of the grass without detrimental effects or customer complaints.

C. Seed

1. Seed shall be labeled in accordance with U.S. Department of Agriculture Rules and Regulations under the Federal Seed Act and Stated seed laws. Seed shall be furnished in sealed standard containers of the vendor. Each seed contained shall bear the name, trade name, or trade mark, warranty of the producer and a certified of the percentage of the purity and germination of each kind of seed specified. Seed which has become wet, moldy or otherwise damage in transit or in storage will not be acceptable.

(a) Seed shall gave a guaranteed germination rate of 95% or greater.

SECTION 02930 - SEEDING

(b) Pure Live Seed (PLS) formula: The following formula shall be used to determine PLS for each kind of seed:

$$\text{PLS (\%)} = [\text{Purity (percent)} \times \text{Germination (percent)}] / 100$$

2. The areas and types of seeding to be used shall be specified on the plans. The types of acceptable seed, depending upon the area is as follows:
 - A. Type "A" Seed: This seeding mixture will normally be used when seeding is required in areas of established yards, shoulders, slopes in the street right-of-way and any other area where a high-type seeding is deemed necessary. The seed shall be sowed at a rate of 10 lbs. PLS per 1000 square feet (436 lbs. PLS per acre). The seed mixture will be 100 percent Turf-Type Tall Fescue compose of an equal mix of three of four compatible species. The mixture shall not include any varieties of the slower growing Turf-Type Tall Fescue "Dwarf". The species shall be one of the following or as approved by the City/Design Professional:

Apache	Arid	Austin
Bonanza	Carefree	Chieftan
Cimmaron	Chochise	Falcon
Guardian	Hounddog	Jaguar II
Maverick II	Mustang	Olympic
Phoenix	Rebel II	Rebel 3D
Safari	Shenandoah	Thoroughbred
Titan	Tribute	Vegas

3. If the property is already planted with zoysia grass, CONTRACTOR shall plant new zoysia grass plugs at the unit price for sodding.

SECTION 02931

SODDING

PART 1 GENERAL

A. Section Description

1. This section provides for areas to be restored with sodding materials.

B. Related Sections

1. Section 02930 – Seeding
2. Section 02070 – Fill Dirt and Topsoil

C. References

1. ASPA (American Sod Producers Association) - Guideline Specifications to Sodding.
2. FS O-F-241 - Fertilizers, Mixed, Commercial.

D. Procedures

1. Sodding areas: All established lawn areas that have been disturbed by construction operations including areas of cut and fill, trenching, temporary roads, and temporary staging or storage areas shall be sodded when indicated on work order.
2. Sequence of Work: Sequence shall be clearing, grading, fertilizing, tilling, sodding and watering.
3. CONTRACTOR shall incorporate appropriate anti-erosion measures as needed on steep slopes.

F. Quality Assurance

1. Materials shall comply with regulatory agencies for fertilizer and herbicide composition and shall not produce an undesirable odor.
2. All sodding work shall be performed by a contractor having demonstrated experience in sodding on projects of similar size. The work shall be prepared by experienced personnel who are familiar with the required work and who are under the supervision of a qualified foreman at all times when the work is in progress.
3. CONTRACTOR shall submit sod certification for grass species and the location of sod source to CITY for approval at the beginning of the CONTRACT and whenever a change in supplier or species is necessary.

SECTION 02931

SODDING

4. Sod Producer: Shall be a company specializing in sod production and harvesting with minimum three years documented experience.

G. Delivery, Storage, and Handling

1. Deliver sod in rolls. Protect exposed roots from dehydration.
2. Do not deliver more sod than can be laid within 24 hours. Sod harvested more than 48 hours prior to placement will be rejected and shall be removed immediately from the site.

PART 2 PRODUCTS

- A. Topsoil: Topsoil used, when necessary or when indicated by the work order, shall conform to section Section 02070 – Fill Dirt and Topsoil

B. Sod

1. The sod to be used as source material shall be a thick stand of Turf Type Tall Fescue, unless otherwise specified by CITY. The Turf Type Tall Fescue shall be composed of an equal mix of three or four compatible species of 100 percent Turf Type Tall Fescue. The mixture shall not include any varieties of the slower growing Turf Type Tall Fescue "Dwarf".
2. The sod shall contain a growth of not more than 1 percent of other grasses and clovers, shall be free from all prohibited and noxious weeds.
3. Shall be a minimum age of 18 months, with root development that will support its own weight without tearing, when suspended vertically by holding the upper two corners.
4. If property is already planted with zoysia grass, CONTRACTOR shall plant new zoysia grass plugs at the unit price for sodding.
5. Broken pads and torn or uneven ends will not be acceptable. Standard size sections shall be strong enough to support their own weight and should retain their size and shape when suspended vertically from a firm grasp on the upper 10 percent of the section. Sod shall not be harvested or transplanted with moisture content (excessively dry or wet) that will adversely affect its survival.

SECTION 02931

SODDING

C. Fertilizer

- A. Fertilizer shall be inorganic 12.12.12 or 13.13.13 grade, uniform in composition, free flowing and suitable for application with approved equipment, delivered to the site in convenient containers, each fully labeled, conforming to applicable state fertilizer laws, bearing the name, trade name, or trade mark and warranty of the producer.

PART 3 EXECUTION

Preparation of Subsoil

A. General:

1. The work shall not be started until all earthwork has been completed. Backfills and fills shall be properly compacted, the topsoil shall be spread and finish grading shall be completed immediately before the sodding work is started.

B. Preparation of Area:

1. Preparation of areas to be sodded shall include filling, reshaping eroded areas, cleaning ditches and refinishing slopes to the established grade section.

C. Cleanup:

1. Within reasonable time after completion of the construction operations and before any sod is installed, the entire area shall be cleared of excess soil and waste material, including, but not limited to, stones, stumps, roots, brush, wire, grade stakes, and all objects that might be a hindrance to maintenance operations or affect the visual appearance of the site. All roads over which hauling operations have been conducted, regardless of the type of surfacing, shall be kept clean, and soil clods and debris left on the surface shall be removed. The wheels of vehicles shall be cleaned to avoid leaving soil upon the surface of roads, walks, and other surfaced areas.

D. Preparation of Sod Bed:

1. After fertilizer has been applied, the areas to be sodded shall be tilled to a depth of at least 2 inches. All operations shall be done in a direction parallel to the contour lines on the slope and not uphill or downhill.

SECTION 02931

SODDING

Fertilizing

- A. Before tilling operations, fertilizer shall be spread uniformly at the rate of 3.5 pounds per 500 square feet.

Laying Sod

- A. Application of Sod: Sod shall be moist when it is placed. Sod strips shall be laid along contour lines, commencing at the lowest point of the area and working upward. The transverse joints of sod strips shall be staggered and the sod carefully placed to produce tight joints. If necessary to walk excessively on newly laid sod, walking boards should be laid for this purpose. The sod shall be firm and watered immediately after it is placed. The "firming" shall be accomplished by application of a roller weighing not less than 60 nor more than 90 pounds per linear foot of roller or other approved method.

Maintenance

- A. Promptly after placing the sod, CONTRACTOR shall wet the sod thoroughly. The property owner will be responsible for additional watering and maintenance after the initial watering.
- B. Water used in this work shall be furnished by the Contractor and will be suitable for irrigation and free from ingredients harmful to plant life. All watering equipment required for the work shall be furnished by the Contractor. Water shall be taken from adjacent fire hydrants or public water lines only through hydrant connections permitted and issued by WSD. Written approval from the property owner shall be obtained prior to the use of water from customer's premises.
- C. If the City inspector determines that the area was not properly completed, the inspector shall require the Contractor to re-prepare and re-sod the area, prior to final acceptance.

Payment

- A. Payment: Payment for sodding will be made at the contract unit bid price per square foot for "Sodding" as listed in Section 00412 – Unit Prices and as stated in Section 01270.

END OF SECTION