



CITY PLAN COMMISSION STAFF REPORT

City of Kansas City, Missouri
City Planning & Development Department
www.kcmo.gov/cpc

June 5, 2024

Project Name

Cookingham Development – Expansion

Docket

- 9.1 Area Plan Amendment
- 9.2 Rezoning without Plan
- 9.3 Development Plan – Non-Residential

Request

CD-CPC-2024-00030
Rezoning without Plan
CD-CPC-2024-00031
Area Plan Amendment
CD-CPC-2024-00032
Development Plan – Non-Residential

Applicant

Aaron March
Rouse Frets White Goss, PC

Owner

Cookingham LLC & Dillingham
Enterprises Inc

Location	2001 NW Cookingham Dr
Area	About 59 Acres
Zoning	M2-3 & AG-R
Council District	1 st
County	Platte
School District	Platte County R-III

Surrounding Land Uses

North: Undeveloped, zoned MPD
South: Interstate 435, zoned AG-R
East: Interstate 435, zoned AG-R
West: Undeveloped, zoned M2-3

KC Spirit Playbook Alignment

N/A

Land Use Plan

The KCI Area Plan recommends open space/buffer and mixed use community for this location.

Major Street Plan

NW Cookingham Drive is identified as a thoroughfare on the City's Major Street Plan.

APPROVAL PROCESS



PROJECT TIMELINE

The application for the subject request was filed on 3/15/2024. Scheduling deviations from 2024 Cycle 5.1 have occurred due to technology issues at City Hall.

REQUIRED PUBLIC ENGAGEMENT

Public engagement as required by 88-505-12 does apply to this request. The applicant hosted a meeting on 4/16/2024. A summary of the meeting is attached to the staff report, see Attachment #3.

EXISTING CONDITIONS

The 59-acre site is undeveloped, generally flat and has a regulated stream that runs on along the eastern and southern perimeters of the site.

SUMMARY OF REQUEST + KEY POINTS

CD-CPC-2024-00030 - A request to rezone about 59 acres from zoning district AG-R to district M2-3 generally located at Interstate 435 and NW Cookingham Drive.

CD-CPC-2024-00031- A request to approve an area plan amendment to the KCIA Area Plan from Mixed Use Community to Commercial/Industrial on about 59 acres generally located at Interstate 435 and NW Cookingham Drive.

CD-CPC-2024-00032 - A request to approve a non-residential development plan to allow for Communications Service Establishments in districts in the proposed M2-3 zoning district on about 59 acres generally located at Interstate 435 and NW Cookingham Drive.

CONTROLLING + RELATED CASES

CD-CPC-2023-00138, CD-CPC-2023-00139 and **CD-CPC-2023-0140** were approved by the City Council on November 30, 2023 to allow for a speculative data center development (**Ordinance No. 230979**).

PROFESSIONAL STAFF RECOMMENDATION

Docket # Recommendation

- 8.1** **APPROVAL**
- 8.2** **APPROVAL**
- 13** **APPROVAL WITH CONDITIONS**

PLAN REVIEW & ANALYSIS

The applicant is expanding a previously approved development plan to allow for a speculative data center (communication service establishment). The proposed expansion will consist of an additional 30 acres east of the previously approved site. The 30 acres are undeveloped, currently zoned for agricultural uses, adjacent to Interstate 435 and generally flat. The applicant will be removing over nine (9) acres of trees but is not required to provide any tree mitigation due to the existing stream buffer that runs along the eastern and southern perimeter of the site. The applicant is also seeking a deviation of 10' to allow for 70' tall structures to be constructed on the site. City staff assigned MoDOT a review due to the proximity of the site to Interstate 435. Also, the City and MoDOT have a cooperative maintenance agreement for NW Cookingham Drive and City staff is awaiting feedback from MoDOT to make sure they approve of the proposed use and possible traffic generation.

**indicates adjustment/deviation*

Standards	Applicability	Meets	More Information
Lot and Building Standards (88-140)*	Yes	No	The applicant is seeking a deviation to allow for building heights up to 70' which exceed the allowable height by 10'.
Tree Preservation and Protection (88-424)	Yes	Yes	The applicant is exempt due to the existing stream buffer.
Parking and Loading Standards (88-420)	Yes	Yes	
Landscape and Screening Standards (88-425)	Yes	Yes, subject to conditions	
Outdoor Lighting Standards (88-430)	Yes	Yes, subject to conditions	
Sign Standards (88-445)	Yes	Yes, subject to conditions	
Pedestrian Standards (88-450)	Yes	Yes, subject to conditions	

SPECIFIC REVIEW CRITERIA

Zoning and Development Code Map Amendments, Rezoning (88-515-08)

In reviewing and making decisions on proposed zoning map amendments, the City Planning and Development Director, City Plan Commission, and City Council must consider at least the following factors:

A. Conformance with adopted plans and planning policies;

The proposed development does require an area plan amendment to the KCI area plan but the use is generally permitted when north of Interstate 435 within this quadrant of the City.

B. Zoning and use of nearby property;

The immediate area is generally zoned AG-R and undeveloped.

C. Physical character of the area in which the subject property is located;

The area is undeveloped and adjacent to Interstate 435.

D. Whether public facilities (infrastructure) and services will be adequate to serve development allowed by the requested zoning map amendment;

The applicant is continuing to coordinate with KC Water related to public infrastructure serving the site.

E. Suitability of the subject property for the use to which it has been restricted under the existing zoning regulations;

The proposed site is adjacent to Interstate 435 and if properly screened from the public right-of-way the proposed zoning will be suitable for the proposed use.

F. Length of time the subject property has remained vacant as zoned;

The proposed site is undeveloped.

G. The extent to which approving the rezoning will detrimentally affect nearby properties; and

The proposed site is adjacent to Interstate 435 and if well screened from the public right-of-way and adjacent properties it should not detrimentally affect nearby properties.

H. The gain, if any, to the public health, safety, and welfare due to denial of the application, as compared to the hardship imposed upon the landowner, if any, as a result of denial of the application.

The proposed use would not be permitted without rezoning the property from AG-R to M2-3.

Development Plans, Project Plan, or Site Plan (88-516-05)

In order to be approved, a development plan, project plan, or site plan must comply with all of the following criteria:

A. The plan must comply with all standards of the Zoning and Development Code and all other applicable city ordinances and policies;

The applicant has outstanding corrections from KC Water and KCPD and no ordinance request can be submitted until the corrections are resolved. The applicant is also seeking a 10' height deviation from the lot and building standards of the Zoning and Development Code to construct 70' tall structures.

B. The proposed use must be allowed in the district in which it is located;

The western side of the project area currently allows for communication service establishments, the applicant has acquired additional property since the original plan was approved in 2023 and is now expanding the use to the east. The eastern portion of the site is zoned AG-R (Agricultural – Residential) and will be rezoned to M2-3 (manufacturing) to allow for the proposed use.

C. Vehicular ingress and egress to and from the site, and circulation within the site must provide for safe, efficient, and convenient movement of traffic not only within the site but on adjacent roadways;

City staff is waiting for MoDOT to complete their review related to amount curb cuts proposed. MoDOT and the City of Kansas City have a shared maintenance agreement for NW Cookingham Drive. Staff has encouraged the developer to have one primary entrance and a second entrance that can only be used by emergency personnel.

D. The plan must provide for safe, efficient, and convenient non-motorized travel opportunities, being pedestrian and bicycle movement, on the subject site;

The proposed use on the site, a data center (communication service establishment), does not generate much pedestrian or bicycle activities. The plan does comply with the Pedestrian Standards (88-450) of the Zoning and Development Code.

E. The plan must provide for adequate utilities based on City standards for the particular development proposed.

The applicant has outstanding corrections from KC Water that shall be resolved prior to ordinance request.

F. The location, orientation, and architectural features, including design and material, of buildings and other structures on the site must be designed to be compatible with adjacent properties.

The proposed architectural features and design are high quality and are compatible with the site's immediate adjacency to Interstate 435.

G. Landscaping, berms, fences, and/or walls must be provided to buffer the site from undesirable views, noises, lighting, or other off-site negative influences and to buffer adjacent properties from negative influences that may be created by the plan.

The applicant did provide a landscape plan that complies with Code and will provide a strong visual buffer along NW Cookingham Drive.

H. The design of streets, drives, and parking areas within the project should result in a minimum of area devoted to asphalt or other impervious surfaces consistent with the needs of the project and city code requirements.

The applicant has stated this is a speculative project which means that the proposed amount of impervious surfaces could change depending on who the end user is.

I. The plan must identify trees to be removed and trees to be preserved during the development of the subject property with the goal of saving trees that are not required to be removed for the development of the property.

The applicant provided a tree preservation and removal plan. The applicant is proposing to remove over 9 acres of trees for the speculative development. No mitigation is required due to the existing stream buffer.

ATTACHMENTS

1. Conditions Report
2. Applicants Submittal
3. Public Engagement Materials

PROFESSIONAL STAFF RECOMMENDATION

City staff recommends the following:

CD-CPC-2024-00030 - Rezoning without Plan	APPROVAL
CD-CPC-2024-00031 - Area Plan Amendment	APPROVAL
CD-CPC-2024-00032 - Development Plan – Non-Residential	APPROVAL WITH CONDITIONS

Respectfully Submitted,

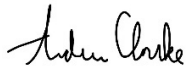

Andrew Clarke, AICP
Planner



Plan Conditions

Report Date: May 29, 2024

Case Number: CD-CPC-2024-00032

Project: Cookingham Development - Expansion

Condition(s) by City Planning and Development Department. Contact Andrew Clarke at (816) 513-8821 / Andrew.Clarke@kcmo.org with questions.

1. The developer shall submit an affidavit, completed by an ISA certified arborist, an SAF certified forester, a professional engineer, or a landscape architect licensed in the State of Missouri, verifying that all trees preserved and all trees planted to meet mitigation required of the approved plan, whichever is applicable, has been installed or preserved in accordance with the plan and is healthy prior to Certificate of Occupancy.
2. The developer shall be responsible for tree preservation in an easement or platted tract, mitigation planting, or payment of cash-in-lieu of preservation or mitigation planting, or any combination thereof in accordance with 88-424. Should the developer choose to pay cash-in-lieu of preservation or mitigation of all or a portion of the required area, the amount due shall be based upon the rate specified in 88-424. This requirement shall be satisfied prior to certificate of occupancy.
3. The developer shall screen all roof and/or ground mounted mechanical and utility equipment in compliance with 88-425-08.
4. The developer shall submit an affidavit, prepared by an engineer licensed in the State of Missouri, verifying that all outdoor lighting has been installed in accordance with approved plans and that lighting levels do not exceed that shown on the approved lighting plan at the property lines prior to Certificate of Occupancy.
5. The developer shall submit an affidavit, completed by a landscape architect licensed in the State of Missouri, verifying that all landscaping required of the approved plan has been installed in accordance with the plan and is healthy prior to Certificate of Occupancy.
6. The developer shall submit an affidavit, completed by a landscape architect licensed in the State of Missouri, verifying that street trees have been installed in accordance with the approved street tree planting plan and are healthy prior to Certificate of Occupancy.
7. The developer shall secure approval of a project plan from the City Plan Commission prior to building permit.
8. All signage shall conform to 88-445 and shall require a sign permit prior to installation.
9. The Council shall grant a deviation to 88-140-04 allowing for a maximum height of 70'.
10. The applicant shall resolve all KC Water and KCPD corrections prior to ordinance request.
11. The developer shall submit a phasing plan to the Development Management Division prior to ordinance request.

Condition(s) by City Planning and Development Department. Contact Matthew Barnes at (816) 513-8817 / matthew.barnes@kcmo.org with questions.

12. That prior to any Certificate of Occupancy is issued for each phase, a Final Plat must be approved by the City and recorded with the County Recorder of Deeds.
13. That the applicant must submit, gain approval from the City, and record a Final Plat for each phase prior to any certificate of occupancy being issued.

Condition(s) by City Planning and Development Department. Contact Terry Thomas at (816) 513-2510 / Terry.A.Thomas@kcmo.org with questions.

14. The developer shall grant a BMP and/or Surface Drainage Easement to the City as required by the Land Development Division, prior to recording the plat or issuance of any building permits.
15. The developer shall dedicate additional right of way [and provide easements] for _____ as required by the adopted [Major Street Plan and/or Chapter 88] so as to provide a minimum of ___ feet of right of way as measured from the centerline, along those areas being platted.

Condition(s) by City Planning and Development Department. Contact Terry Thomas at (816) 513-2510 / Terry.A.Thomas@kcmo.org with questions.

16. The developer shall submit plans for grading, siltation, and erosion control to Land Development Division for review and acceptance, provide a copy of the Storm Water Pollution Prevention (SWPP) plan submitted to the Missouri Dept. of Natural Resources (MDNR) and secure a Site Disturbance permit for any proposed disturbance area equal to one acre or more prior to beginning any construction activities.
17. The developer shall submit construction plans in compliance with adopted standards for all improvements required by the traffic study approved by the Public Works Department, and shall secure permits for those improvements as required by the Land Development Division, prior to recording the plat.
18. The developer shall submit verification of vertical and horizontal sight distance for the drive connection to public right-of-way to the Land Development Division and make improvements to ensure local jurisdiction and/or minimum AASHTO adequate sight distance standards are met, prior to issuance of any certificate of occupancy.
19. The developer shall pay impact fees as required by Chapter 39 of the City's Code of ordinances as required by the Land Development Division.
20. The developer shall cause the area to be platted and processed in accordance with Chapter 88, Code of Ordinances of the City of Kansas City, Missouri.
21. The developer shall submit a streetscape plan for approval and permitting by the Land Development Division prior to beginning construction of the streetscape improvements in the public right of way, and construct ADA compliant ramps at all required locations where new private drives are being added, or where existing sidewalks are modified or repaired.
22. The developer shall enter into a covenant agreement for the maintenance of any stormwater detention area tracts as required by the Land Development Division, prior to recording the plat.
23. The developer shall submit a Macro storm drainage study with the first Plat or Phase, from a Missouri-licensed civil engineer to the Land Development Division showing compliance with current adopted standards in effect at the time of submission, including Water Quality BMP's, to the Land Development Division for review and acceptance for the entire development area, and submit Micro storm drainage study with each subsequent Plat or Phase showing compliance with the approved Macro and adopted standards. The developer shall secure permits to construct any improvements as necessary to mitigate impacts from rate, volume, and quality of runoff from each proposed phase, prior to recording the plat or prior to issuance of a Building Permit, whichever occurs first as required by the Land Development Division.
24. The developer shall secure permits to extend public sanitary and storm water conveyance systems to serve all proposed lots within the development and determine adequacy of receiving systems as required by the Land Development Division, prior to recording the plat or issuance of a building permit whichever occurs first.

Condition(s) by Fire Department. Contact Michael Schroeder at (816) 513-4604 / michael.schroeder@kcmo.org with questions.

25. • The developer shall meet the fire flow requirements as set forth in Appendix B of the project International Fire Code 2018. (IFC-2018 § 507.1)
26. • Buildings equipped with a fire standpipe system shall have an operable fire hydrant within 100 feet of the Fire Department Connection (FDC). (IFC2018 § 507.5.1.1)
27. • Fire hydrants shall be installed and operable prior to the arrival of any combustible building materials onto the site. (IFC-2018 § 501.4 and 3312.1; NFPA 241-2013 § 8.7.2)
 - Fire hydrant distribution shall follow IFC-2018 Table C102.1
28. • Aerial Fire Apparatus access roads shall be provided for any building that is 30 feet in height or greater. Aerial Fire Apparatus Roads are a minimum 26 feet wide, at least 15 feet away from the building but not more than 30 feet from the structure. (IFC-2018 § D105).
 - Buildings exceeding three (3) stories or 30 feet in height shall have at least two means of fire apparatus access. (IFC-2018: § D104.1)
29. • Security gates which span across a fire access road shall provide a means for emergency operation. Electric gates shall require a siren sensor device typically referred to as a "yelp gate" (IFC-2018 § 503.6).

Condition(s) by Fire Department. Contact Michael Schroeder at (816) 513-4604 / michael.schroeder@kcmo.org with questions.

30. • A required fire department access roads shall be an all weather surface. (IFC-2012: § 503.2.3)
 - Fire Department access roads shall be provided prior to construction/demolition projects begin. (IFC-2018 § 501.4 and 3310.1; NFPA 241-2013 § 7.5.5)
 - Required fire department access roads shall designed to support a fire apparatus with gross axle weight of 85,000 pounds. (IFC-2018: § 503.2.3)
 - The turning radius for fire department access roads shall be 30 feet inside and 50 feet outside radius. (IFC-2018: § 503.2.4)
 - Shall provide fire lane signage on fire access drives.
31. • New buildings shall have approved radio coverage for emergency responders within the building based on the existing coverage levels of the public safety communication systems utilized by the jurisdiction, measured at the exterior of the building. This section shall not require improvement of the existing public safety communication systems. (IFC 2018 510.1) and (NFPA1221)

Condition(s) by Water Services Department. Contact Heather Massey at (816) 513-2111 / heather.massey@kcmo.org with questions.

32. Water/Sewer Service lines shall serve only one lot or tract and shall not cross a separate lot or tract.
33. No water service tap permits will be issued until the public water main is released for taps.
34. The developer shall ensure that water and fire service lines should meet current Water Services Department Rules and Regulations. Prior to C of O.
<https://www.kcwater.us/wp-content/uploads/2022/05/2022-Rules-and-Regulations-for-Water-Service-Lines-Final.pdf>
35. A full flow fire meter shall be required when the fire protection service line serves more than one building, or combination service lines 6 inches and larger, or that have private fire hydrants connected to them.

Condition(s) by Water Services Department. Contact Kirk Rome at (816) 513-0368 / kirk.rome@kcmo.org with questions.

36. Relocations and additions to the public water distribution system and public fire hydrants shall follow the KC Water Rules and Regulations for Water Main Extensions. Developer shall submit water main extension plans for review, approval, contracting, and construction of the proposed water distribution improvements prior to building permit issuance.

Condition(s) by Water Services Department. Contact Lucas Kaspar at (816) 513-2131 / Lucas.Kaspar@kcmo.org with questions.

37. The developer must grant BMP and Surface Drainage Easements to the City, prior to recording the plat or issuance of any building permits.
38. The developer shall submit a final stream buffer plan for approval prior to issuance of any building permits and obtain permits for the Stream Buffer prior to removal of any mature riparian species within the buffer zones due to construction activities on the site, in accordance with the Section 88-415 requirements.
39. The developer must secure permits to extend public sanitary and storm water conveyance systems to serve all proposed lots within the development and determine adequacy of receiving systems, prior to recording the plat or issuance of a building permit whichever occurs first.
40. The developer must obtain a floodplain certificate from Development Services prior to beginning any construction activities with the floodplain.
41. The developer must show the limits of the 100-year floodplain on the final plat and show the Minimum Low Opening Elevation (MLOE) of any structure on each lot that abuts a 100-year flood prone area (including detention basins and engineered surface drainage conveyances) on any plat and plan.
42. The developer shall submit a Preliminary Stream Buffer plan prior to approval of the plan in accordance with the Section 88-415 requirements.
43. The developer must grant on City approved forms, a STREAM BUFFER Easement to the City, as required by Chapter 88, prior to issuance of any stream buffer permits.

Condition(s) by Water Services Department. Contact Lucas Kaspar at (816) 513-2131 / Lucas.Kaspar@kcmo.org with questions.

44. The developer must enter into a covenant agreement for the maintenance of any storm water detention area tracts, prior to recording the plat.

PRELIMINARY DEVELOPMENT PLAN & PRELIMINARY PLAT FOR COOKINGHAM DEVELOPMENT

Part of the NW & NE 1/4
Section 21-Township 52S-Range 33E
in the
City of Kansas City
Platte County, Missouri

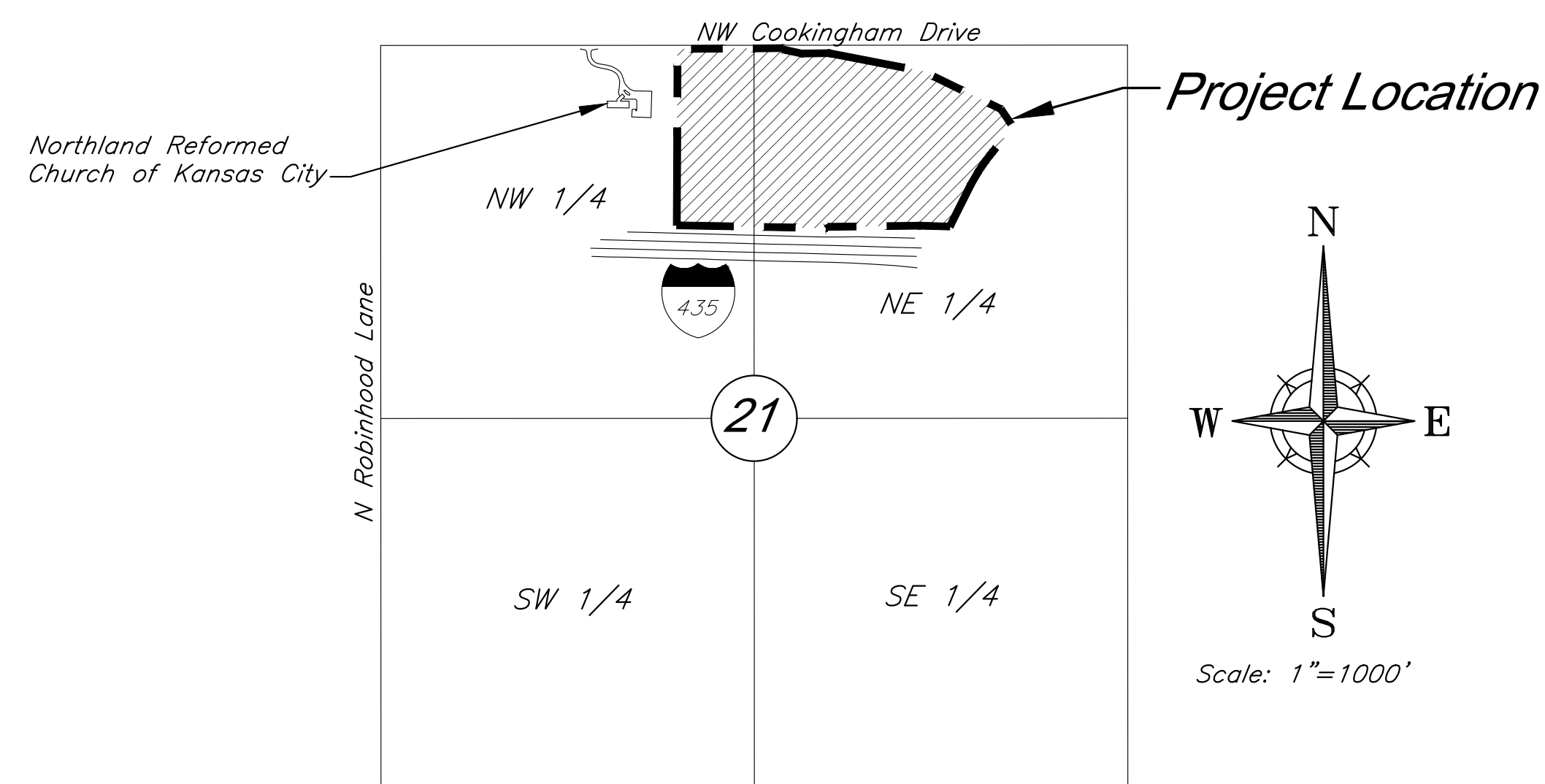

VICINITY MAP
Part of the NW & NE 1/4
Section 21-Township 52-Range 33

INDEX OF SHEETS

Sht. No.	Description
1	Title Sheet
2	General Layout
3-4	Site Plan
5	Landscape Plan
6	Street Tree Plan
7	Planting Details
8-9	Grading Plan
10-11	Utility Plan
12	Tree Removal & Tree Preservation Plan
13	Preliminary Plat
14	Stream Buffer Plan
E1.1	Lighting Plan
E1.2	Lighting Plan
A4.1 - Color	Partial Building Elevations
A4.2 - Color	Partial Building Elevations
A4.3 - Color	Partial Building Elevations

PREPARED FOR:
GBA REALTY LLC
9801 RENNER BOULEVARD
LENEXA, KANSAS 66219
PHONE: 816-876-3893
CONTACT: GRAHAM JONES LEED AP
EMAIL: gjones@gbabuilders.com

PREPARED BY:
GEORGE BUTLER ASSOCIATES, INC.
9801 RENNER BOULEVARD
LENEXA, KANSAS 66219
PHONE: 913-492-0400
CONTACT: CLINT LOUMASTER P.E.
EMAIL: cloumaster@gbateam.com

FLOODPLAIN:

According to the Flood Insurance Rate Maps (FIRMs) for the city of Kansas City, Missouri (29095C0061G, dated January 20th, 2017), the site is situated mainly within Zone X, areas determined to be outside the 0.2% annual chance floodplain. A channel on the site contains Zone AE, special flood hazard areas.

DEVIATIONS REQUESTED:

1. A deviation is requested to allow facilities up to 70 feet in height on each of the proposed lots.

PROJECT ENGINEER: CLINT LOUMASTER, P.E.

DATE:

APPROVED BY:

MANAGER, ENGINEERING SERVICES DIVISION:

DATE:

GBA

9801 Renner Boulevard
Lenexa, Kansas 66219
913.492.0400
www.gbateam.com

LEGAL DESCRIPTION

ALL THAT PART OF THE EAST 32 ACRES OF THE NORTHWEST 1/4 TOGETHER WITH THAT PART OF THE WEST 32.29 ACRES OF THE NORTHEAST 1/4 OF SECTION 21, TOWNSHIP 52 NORTH, RANGE 33 WEST OF THE 5TH PRINCIPAL MERIDIAN, KANSAS CITY, PLATTE COUNTY, MISSOURI, WHICH LIES SOUTHERLY OF MISSOURI STATE HIGHWAY ROUTE NO. 291 AND NORTHERLY OF INTERSTATE HIGHWAY NO. 435, MORE PARTICULARLY DESCRIBED BY TIMOTHY BLAIR WISWELL, OF GEORGE BUTLER ASSOCIATES, INC., CLS 000059, ON MARCH 14, 2024, AS FOLLOWS:

COMMENCING AT THE NORTHWEST CORNER OF SAID NORTHWEST 1/4; THENCE N89° 33' 48" E ON THE NORTH LINE OF SAID NORTHWEST 1/4, 2644.88 FEET TO AN AXLE AT THE APPARENT NORTHEAST CORNER OF SAID NORTHWEST 1/4; THENCE S0° 14' 35" W ON THE EAST LINE OF SAID NORTHWEST 1/4, 25.00 FEET TO THE POINT OF BEGINNING ON THE SOUTH RIGHT-OF-WAY LINE OF COOKINGHAM DRIVE; THENCE N89° 24' 08" E ON SAID SOUTH RIGHT-OF-WAY LINE, 209.70 FEET TO THE SOUTH RIGHT-OF-WAY LINE OF MISSOURI HIGHWAY ROUTE 291; THENCE S0° 47' 11" E ON SAID SOUTH RIGHT-OF-WAY LINE, 9.53 FEET TO A POINT 30.00 FEET LEFT OF CENTERLINE HIGHWAY STATION 665+00; THENCE S77° 57' 48" E ON SAID SOUTH RIGHT-OF-WAY LINE, 135.17 FEET TO A POINT 60.00 FEET LEFT OF CENTERLINE HIGHWAY STATION 664+10 BACK = 663+68.2 AHEAD; THENCE N89° 12' 49" E ON SAID SOUTH RIGHT-OF-WAY LINE, 185.61 FEET TO THE EAST LINE OF SAID WEST 32.29 ACRES; THENCE S0° 08' 10" W ON SAID EAST LINE, 1233.67 FEET TO THE NORTH RIGHT-OF-WAY LINE OF INTERSTATE HIGHWAY ROUTE 435; THENCE N88° 59' 07" W ON SAID NORTH RIGHT-OF-WAY LINE, 529.74 FEET TO THE EAST LINE OF SAID NORTHWEST 1/4; THENCE CONTINUING N88° 59' 07" W ON SAID NORTH RIGHT-OF-WAY LINE, 529.24 FEET TO THE WEST LINE OF SAID EAST 32 ACRES; THENCE N0° 08' 21" E ON SAID EAST LINE, 1243.85 FEET TO THE SOUTH RIGHT-OF-WAY LINE OF SAID COOKINGHAM DRIVE BEING 25.00 FEET SOUTH FROM, AS MEASURED PERPENDICULAR TO, THE NORTH LINE OF SAID NORTHWEST 1/4; THENCE N89° 33' 48" E ON SAID SOUTH RIGHT-OF-WAY LINE, 531.49 FEET TO THE POINT OF BEGINNING.

AND ALL THAT PART OF THE NORTHEAST QUARTER OF SECTION 21, TOWNSHIP 52 NORTH, RANGE 33 WEST OF THE 5TH PRINCIPAL MERIDIAN, KANSAS CITY, PLATTE COUNTY, MISSOURI, WHICH LIES SOUTHERLY OF MISSOURI STATE HIGHWAY ROUTE NO. 291 AND NORTHERLY OF INTERSTATE HIGHWAY NO. 435, MORE PARTICULARLY DESCRIBED BY TIMOTHY BLAIR WISWELL, PLS 2009000067, OF GEORGE BUTLER ASSOCIATES, INC., CLS 000059, ON MARCH 14, 2024, AS FOLLOWS:

COMMENCING AT THE NORTH CORNER OF SAID SECTION 21; THENCE N89°24'10"E ON THE NORTH LINE OF SAID SECTION 21, A DISTANCE OF 527.78 FEET TO A POINT ON THE NORTHERLY EXTENSION OF THE EAST LINE OF SPECIAL WARRANTY DEED INSTRUMENT #2020011315, BOOK 1335, PAGE 367; THENCE S00°08'57"W ON SAID EXTENDED LINE, A DISTANCE OF 63.48 FEET TO A FOUND 1/2" REBAR, SAID POINT ALSO BEING ON THE SOUTH RIGHT-OF-WAY LINE OF HIGHWAY ROUTE 291, THE POINT OF BEGINNING; THENCE N89°13'23"E, ON SAID SOUTH RIGHT-OF-WAY LINE, A DISTANCE OF 26.52 FEET, TO A POINT BEING 60 FEET SOUTH OF ROUTE NO. 291 CENTERLINE STATION 661+98.40; THENCE S83°17'47"E ON SAID SOUTH LINE, A DISTANCE OF 95.57 FEET, TO A POINT BEING 70 FEET SOUTH OF STATION 661+00.00, SAID POINT ALSO BEING THE BEGINNING OF A NON-TANGENT CURVE; THENCE ON SAID CURVE TO THE RIGHT, HAVING AN INITIAL TANGENT OF N87°49'27"W, A RADIUS OF 1839.86, THROUGH A CENTRAL ANGLE OF 10°00'03", AND AN ARCH LENGTH OF 321.63 FEET, TO A POINT BEING 70 FEET SOUTH OF STATION 657+66.62, AND THE MOST WESTERLY CORNER OF WARRANTY DEED 40903 BOOK 559 PG 708; THENCE S63°31'08"E, DEPARTING SAID SOUTH RIGHT-OF-WAY LINE, ON THE SOUTH LINE OF SAID DEED, A DISTANCE OF 879.52 FEET TO THE MOST SOUTHEASTERN CORNER OF SAID DEED, ALSO BEING 76.89 FEET LEFT/SOUTHWEST OF STATION 648+42.48; THENCE S34°01'43"E, ON THE SOUTH RIGHT-OF-WAY LINE OF SAID ROUTE 291, SHOWN ON THE HIGHWAY NO. 435 PLANS, A DISTANCE OF 91.18 FEET, TO A POINT, 100.0 FEET, LEFT/SOUTHWEST, OF STATION 647+50; THENCE S88°28'48"E ON SAID RIGHT OF WAY LINE, A DISTANCE OF 10.61 FEET, TO A POINT ON THE WEST LINE OF WARRANTY DEED 40903 BOOK 559 PG 708; THENCE S41°01'39"W, DEPARTING SAID RIGHT-OF-WAY LINE, ON SAID WEST LINE, A DISTANCE OF 185.49 FEET TO A POINT OF CURVATURE; THENCE ON SAID CURVE TO THE LEFT, AND ON SAID WEST LINE, HAVING A RADIUS OF 1367.39 FEET, THROUGH A CENTRAL ANGLE OF 15°00'00" AN ARC LENGTH OF 357.98 FEET, TO A POINT OF TANGENCY; THENCE S26°01'39"W ON SAID WEST LINE, A DISTANCE OF 293.70 FEET, TO A POINT ON THE NORTHERLY RIGHT OF WAY LINE OF INTERSTATE HIGHWAY NO. 435, 175.00 FEET NORTH OF STATION 931+88.32; THENCE N88°58'21"W ON SAID NORTHERLY RIGHT OF WAY LINE, A DISTANCE OF 212.32 FEET, TO A POINT BEING 175.00 FEET NORTH OF STATION 729+76.00; THENCE S88°45'19"W ON SAID NORTHERLY RIGHT OF WAY LINE A DISTANCE OF 630.55 FEET, TO A FOUND 1/2" REBAR, ALSO BEING 150.00 FEET NORTH OF STATION 924+50.00; THENCE N0°00'51"E, DEPARTING SAID NORTH RIGHT-OF-WAY LINE, ON THE EAST LINE OF SPECIAL WARRANTY DEED INSTRUMENT #2020011315, BOOK 1335, PAGE 367, A DISTANCE OF 1233.92 FEET, TO THE POINT OF BEGINNING.

CONTAINING 26.82 ACRES - 1,168,062.44 SQ FEET AND BEING SUBJECT TO THAT PART IN ROAD RIGHT-OF-WAY IF ANY.

- ### Legend
- Proposed Building
 - Property Boundary
 - Concrete Sidewalk
 - Proposed Asphalt Pavement
 - Existing Tree Line
 - Emergency Entrance Pending City Approval
 - Proposed Right-of-Way
 - Lot Line
 - 60' Building Setback
 - 20' Parking Setback
 - Proposed Security Fence
 - Proposed Water Line
 - Proposed Storm Sewer
 - Proposed Sanitary Sewer
 - Proposed Sanitary Manhole
 - Proposed Storm Structure
 - Proposed Fire Hydrant

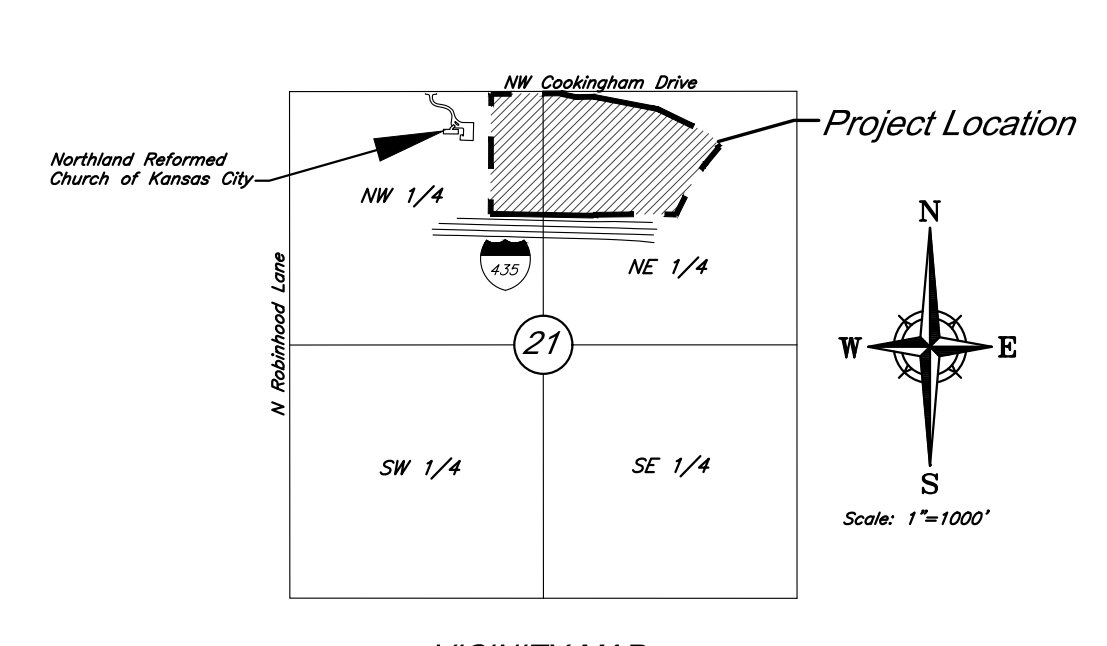

GBA		DATE: 3/15/2024
8901 Renner Blvd., Ste. 300 Lenexa, KS 66219 913.492.0400 gbateam.com		DESIGN BY: CEL
		DRAWN BY: DRV/ELS
		PROJECT NO.: 15410.11
		SHEET NUMBER
		2
Clint Loumaster Professional Engineer License No. PB-2011009651		M2-3 Rezoning - Pre. Development Plan & Pre. Plat
		COOKINGHAM DEVELOPMENT Kansas City, Missouri
NO.	DATE	REVISIONS
1	4/19/24	City Comments 4/5/2024
		BY APPROVED
		ELS

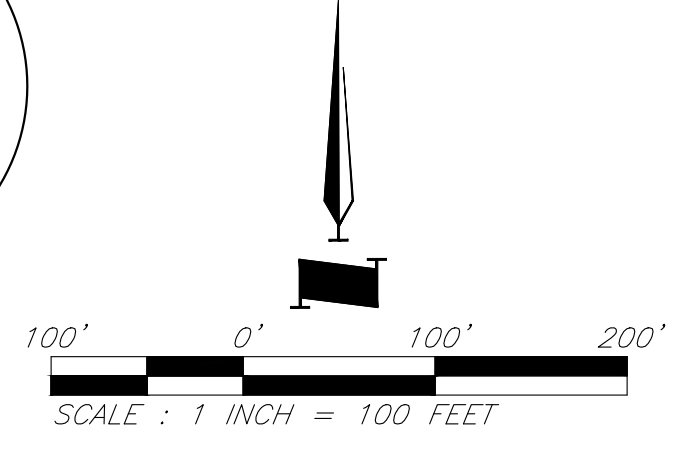
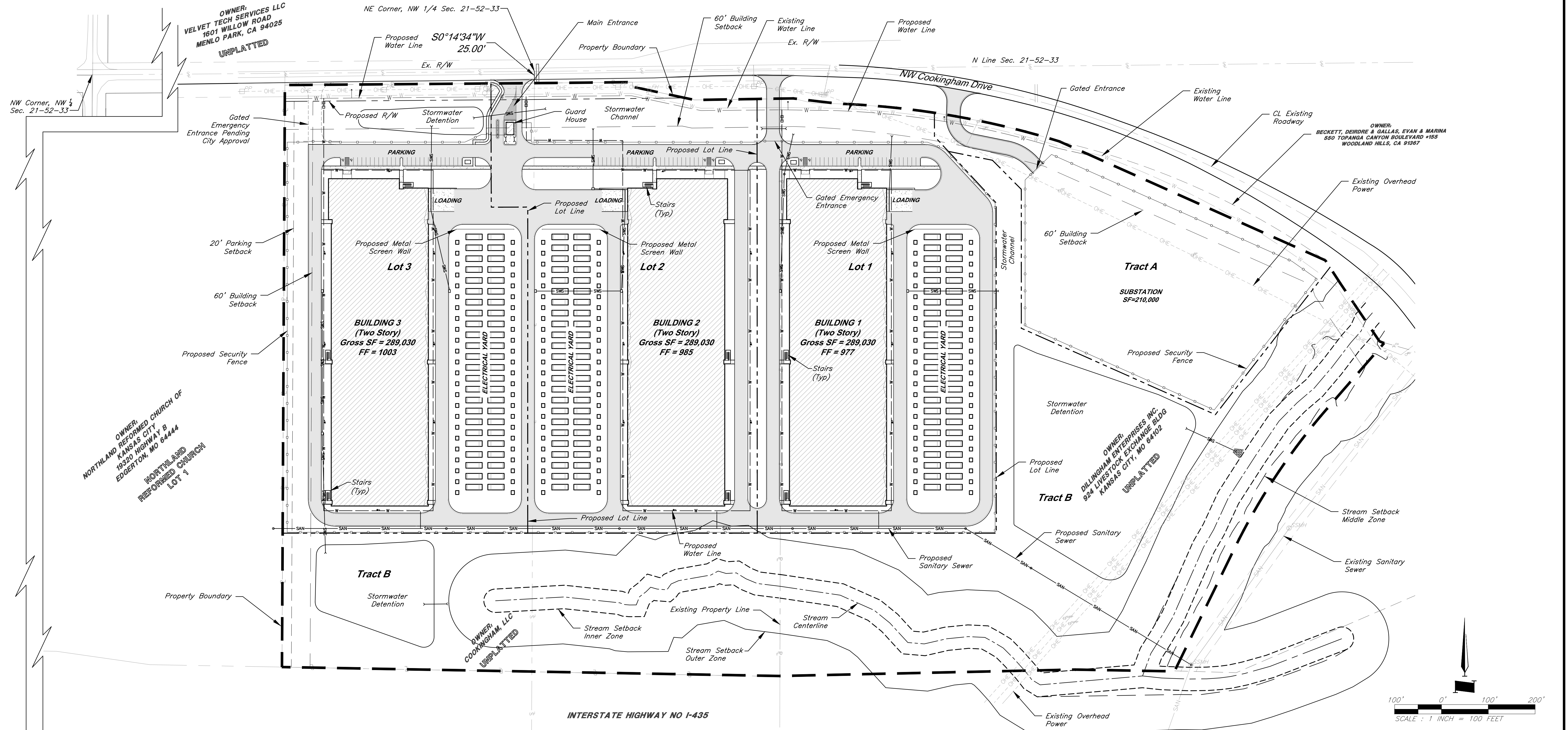

General Layout

C:\15410.11\Civil\Production Drawings\Rezoning & Preliminary Development Plans\15410.11\020200.dwg Layout: 2 General Layout -- Friday, April 19, 2024, 1:47pm -- Copyright 2024, George Butler Associates, Inc. Architect: 00212, Professional Engineer: 0001131, Professional Land Surveyor: 000059

C:\15410.1\1\Production Drawings\Rezonig & Preliminary Development Plans\15410.1\102000.dwg Layout: 3 Site Plan -- Friday April 19, 2024, 1:48pm -- Copyright 2024, George Butler Associates, Inc. Architect 00212, Professional Engineer 000133, Professional Land Surveyor 000269

OWNER:
VELVET TECH SERVICES LLC
UNPLATTED

GBA
8901 Renner Blvd., Ste. 300
Lenexa, KS 66219
913.492.0400
gba.com

DATE: 3/15/2024
DESIGN BY: CEL
DRAWN BY: DRV/ELS
PROJECT NO.: 15410.11
SHEET NUMBER: 3

Clint Loumaster
Professional Engineer
License No. PB-2011009651

M2-3 Rezoning - Pre. Development Plan & Pre. Plat
COOKINGHAM DEVELOPMENT
Kansas City, Missouri

NO. DATE REVISIONS BY APPROVED
1 4/19/24 City Comments 4/5/2024 ELS

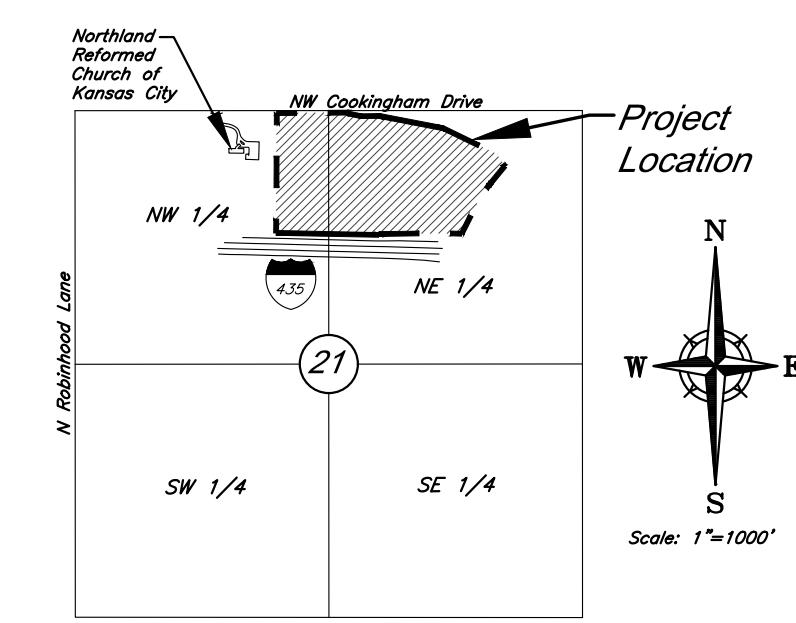

Allowable Uses:
The Uses allowed as of right under zoning district M-2 shall be permitted within this Preliminary Development Plan including, but not limited to: Utilities and Services, Building Maintenance Services, Business Equipment Sales and Service, Business Support Service, Parking (Accessory), Parking (Non-Accessory), Manufacturing, Production, and Industrial Service including: Artisan, Limited, General, Warehousing, Wholesaling, Storage, and Freight Movement including: Indoor, Outdoor, Wireless Communication Facility (Freestanding, Co-located Antenna), Communication Service Establishments, Office, Administrative, Professional, or General, and any and all related accessory uses thereto.

- General Notes:**
- All buildings and other structures shall be constructed of high quality materials including masonry, concrete, glass, and metal (when used in an incidental role). Specific materials which will be excluded include exposed (i) galvanized metal facades, (ii) nondecorative cinder or concrete block, and (iii) double T concrete panels. Accessory buildings, Compactors, appurtenant structures to, or extrusions from, any building or structure shall be of similar or compatible materials, design and construction.
 - All signage will comply with Section 88-445 of the zoning and development code and will be reviewed at time of sign permit.
 - All rooftop mechanical equipment will be screened as required by 88-425-08 of the zoning and development code.
 - Each security gate shall be provided with a siren sensor (Yelp Gate) for Fire Department access.
 - Two way emergency radio communication system provided in accordance with NFPA 1221 and IFC Section 5. A minimum inbound/outbound -95db signal strength or as required by the authority having jurisdiction will be provided.
 - Proposed address for each facility is to be located in a highly visible and prominent location.
 - Facility will be secured by guards in two shifts, with overnight internal monitoring and CCTV cameras. Access gates to facility will be locked at night.

SITE DATA per APPLICATION SUBMITTAL REQUIREMENTS

a) Existing Zoning: AG-R & M2-3
Proposed Zoning: M2-3

Item	Lot 1		Lot 2		Lot 3		Tract A		Tract B		Total
	Existing	Proposed	Existing	Proposed	Existing	Proposed	Existing	Proposed	Existing	Proposed	
b) Total Land Area (SFT)	449,865	449,865	484,658	484,658	479,404	479,404	218,275	218,275	861,148	861,148	2,493,350
Total Land Area (AC)	10.33	10.33	11.13	11.13	11.01	11.01	5.01	5.01	19.77	19.77	57.24
c) Street ROW (SFT)	0	0	0	11,992	0	15,413	0	0	0	0	27,405
Land Area for Street ROW (AC)	0.00	0.00	0.00	0.28	0.00	0.35	0.00	0.00	0.00	0.00	0.63
d) Net Land Area (SFT)		449,865		472,666		463,991		218,275		861,148	2,465,945
Net Land Area (AC)		10.33		10.85		10.65		5.01		19.77	56.61
e) Building Use	AG-R	Communication Service Establishment	AG-R	Communication Service Establishment	AG-R	Communication Service Establishment					
f) Building Height Above Grade (FT)		44*		44*		44*					
# of Floors		2		2		2					
g) Gross Floor Area per Floor (SFT)		144,515		144,515		144,515					
Gross Floor Area per Lot (SFT)		289,030		289,030		289,030					867,090
h) Coverage (SFT)		144,515		144,515		144,515					433,545
Floor Area Ratio		0.642		0.611		0.623					0.352
i) NA											
Vehicle Parking											
j) Spaces	18	27	18	27	18	27					81
k) Bicycle Parking											
l) Spaces	7	7	7	7	7	7					21
m) NA											

* A deviation is requested to allow building heights up to 70 feet on each of the proposed lots.

DEVELOPMENT STANDARDS

88-425 - OTHER DEVELOPMENT STANDARDS	METHOD OF COMPLIANCE
88-415 Stream Buffers	
88-445 Signs	

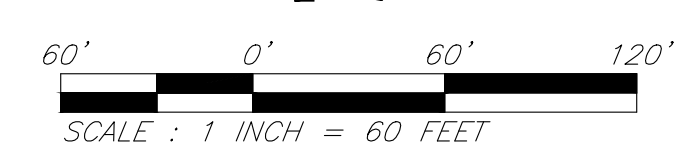
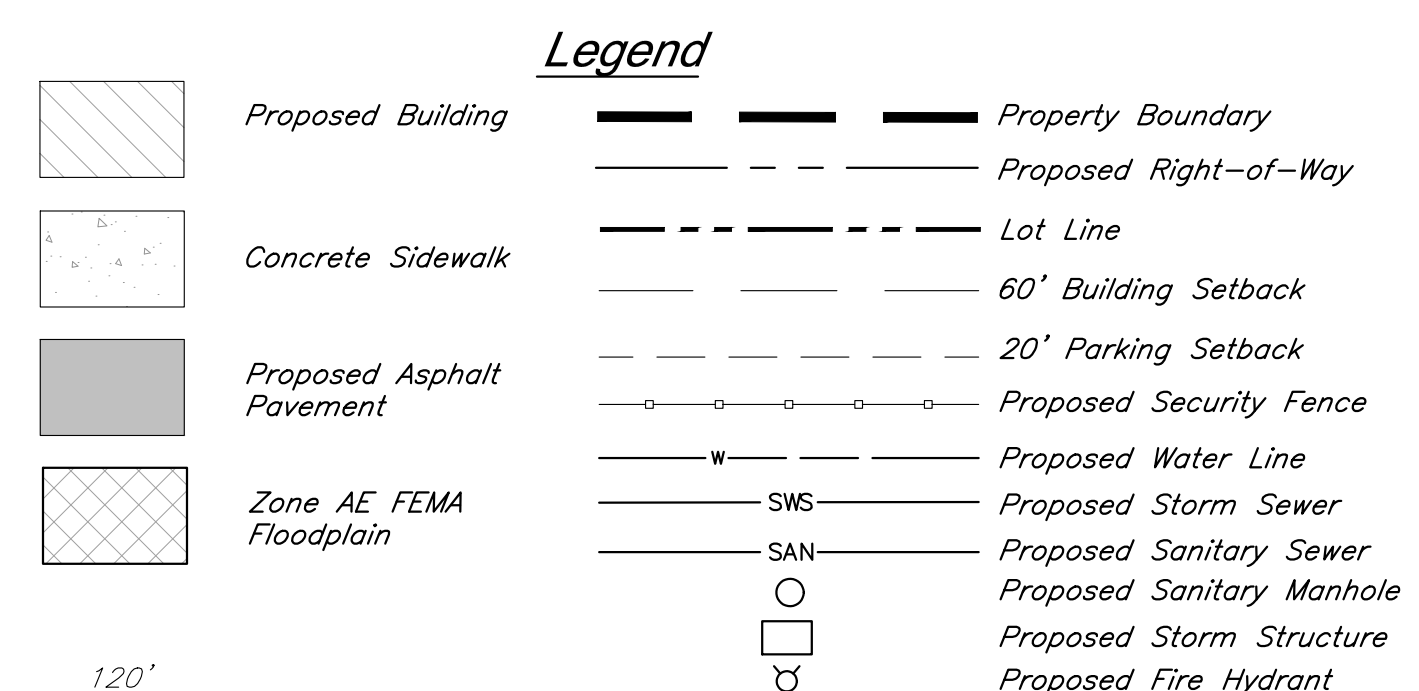

Site Plan

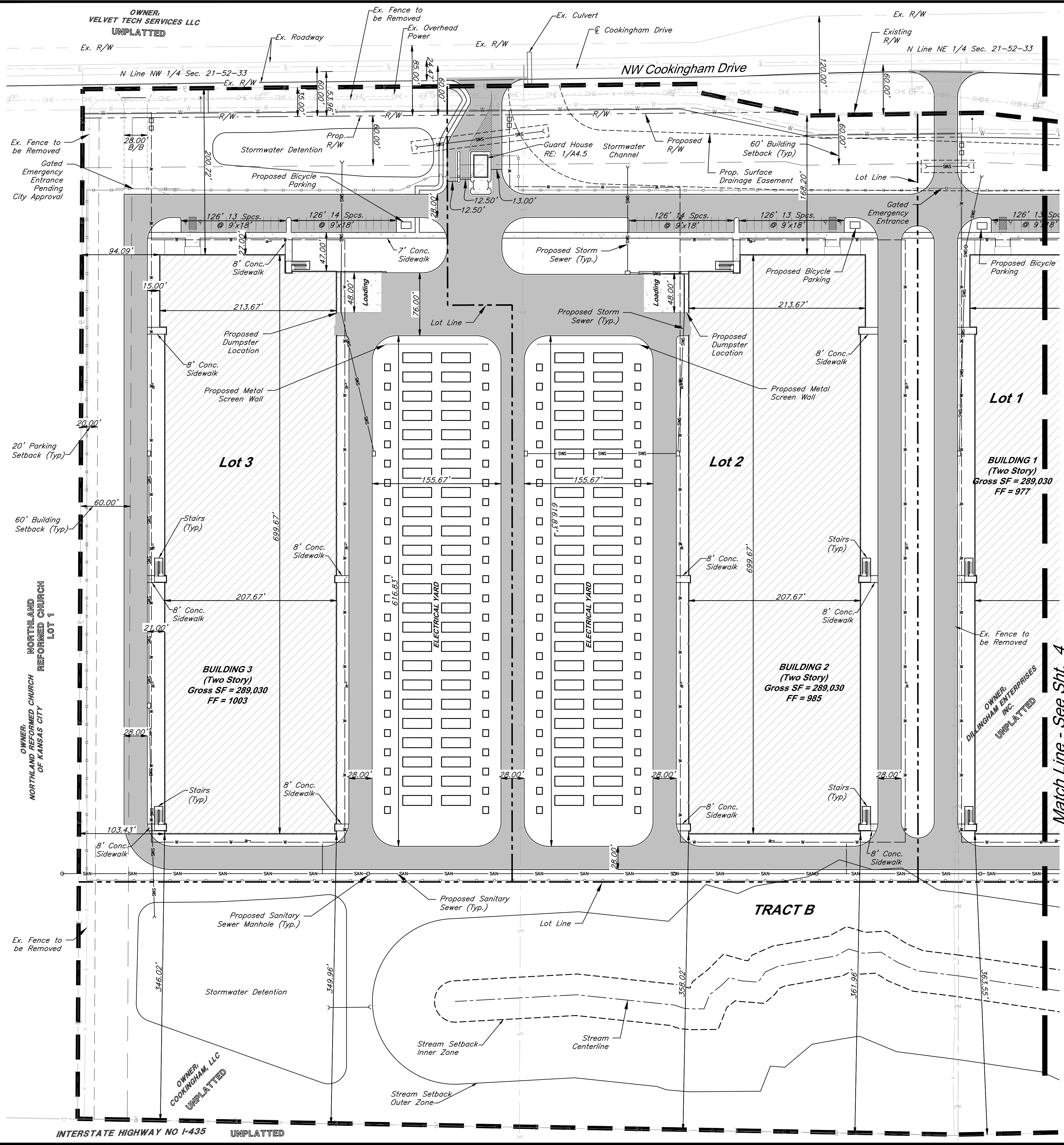

C:\15410.11\Civil\3D\Production Drawings\Rezoning & Preliminary Development Plans\15410.11\02000.dwg Layout: 4 Site Plan - Friday April 19, 2024, 1:48pm - Copyright 2024, George Butler Associates, Inc. Architect: 00212, Professional Engineer: 00113, Professional Land Surveyor: 000269

OWNER:
VELVET TECH SERVICES LLC
UNPLATTED

N Line Sec. 21-52-33

VICINITY MAP
Part of the NW & NE 1/4
Section 21-Township 52-Range 33

GBA
8901 Renner Blvd., Ste. 300
Lenexa, KS 66219
913.492.0400
gbateam.com

DATE: 3/15/2024
DESIGN BY: CEL
DRAWN BY: DRV/ELS
PROJECT NO.: 15410.11
SHEET NUMBER: **4**

Clint Loumaster Professional Engineer License No. PB-2011009651		M2-3 Rezoning - Pre. Development Plan & Pre. Plat COOKINGHAM DEVELOPMENT Kansas City, Missouri	
NO.	DATE	REVISIONS	BY
1	4/19/24	City Comments 4/5/2024	ELS

Allowable Uses:
The Uses allowed as of right under zoning district M-2 shall be permitted within this Preliminary Development Plan including, but not limited to: Utilities and Services, Building Maintenance Services, Business Equipment Sales and Service, Business Support Service, Parking (Accessory), Parking (Non-Accessory), Manufacturing, Production, and Industrial Service including: Artisan, Limited, General, Warehousing, Wholesaling, Storage, and Freight Movement including: Indoor, Outdoor, Wireless Communication Facility (Freestanding, Co-located Antenna), Communication Service Establishments, Office, Administrative, Professional, or General, and any and all related accessory uses thereto.

- General Notes:**
- All buildings and other structures shall be constructed of high quality materials including masonry, concrete, glass, and metal (when used in an incidental role). Specific materials which will be excluded include exposed (i) galvanized metal facades, (ii) nondecorative cinder or concrete block, and (iii) double T concrete panels. Accessory buildings, Compactors, appurtenant structures to, or extrusions from, any building or structure shall be of similar or compatible materials, design and construction.
 - All signage will comply with Section 88-445 of the zoning and development code and will be reviewed at time of sign permit.
 - All rooftop mechanical equipment will be screened as required by 88-425-08 of the zoning and development code.
 - Each security gate shall be provided with a siren sensor (Yelp Gate) for Fire Department access.
 - Two way emergency radio communication system provided in accordance with NFPA 1221 and IFC Section 5. A minimum inbound/outbound -95db signal strength or as required by the authority having jurisdiction will be provided.
 - Proposed address for each facility is to be located in a highly visible and prominent location.
 - Facility will be secured by guards in two shifts, with overnight internal monitoring and CCTV cameras. Access gates to facility will be locked at night.

SITE DATA per APPLICATION SUBMITTAL REQUIREMENTS
a) Existing Zoning: AG-R & M2-3
Proposed Zoning: M2-3

Item	Lot 1		Lot 2		Lot 3		Tract A		Tract B		Total
	Existing	Proposed	Existing	Proposed	Existing	Proposed	Existing	Proposed	Existing	Proposed	
b) Total Land Area (SFT)	449,865	449,865	484,658	484,658	479,404	479,404	218,275	218,275	861,148	861,148	2,493,350
Total Land Area (AC)	10.33	10.33	11.13	11.13	11.01	11.01	5.01	5.01	19.77	19.77	57.24
c) Street ROW (SFT)	0	0	0	11,992	0	15,413	0	0	0	0	27,405
Land Area for Street ROW (AC)	0.00	0.00	0.00	0.28	0.00	0.35	0.00	0.00	0.00	0.00	0.63
d) Net Land Area (SFT)		449,865		472,666		463,991		218,275		861,148	2,465,945
Net Land Area (AC)		10.33		10.85		10.65		5.01		19.77	56.61
e) Building Use	AG-R	Communication Service Establishment	AG-R	Communication Service Establishment	AG-R	Communication Service Establishment					
f) Building Height Above Grade (FT)		44*		44*		44*					
# of Floors		2		2		2					
g) Gross Floor Area per Floor (SFT)		144,515		144,515		144,515					
Gross Floor Area per Lot (SFT)		289,030		289,030		289,030					867,090
h) Coverage (SFT)		144,515		144,515		144,515					433,545
Floor Area Ratio		0.642		0.611		0.623					0.352
i) NA											
j) Vehicle Parking Spaces	18	27	18	27	18	27					81
k) Bicycle Parking Spaces	7	7	7	7	7	7					21
l) NA											
m) NA											

* A deviation is requested to allow building heights up to 70 feet on each of the proposed lots.

DEVELOPMENT STANDARDS

STANDARD	METHOD OF COMPLIANCE
88-425 - OTHER DEVELOPMENT STANDARDS	
88-415 Stream Buffers	
88-445 Signs	

Legend

- Proposed Building
- Concrete Sidewalk
- Proposed Asphalt Pavement
- Zone AE FEMA Floodplain
- Property Boundary
- Proposed Right-of-Way
- Lot Line
- 60' Building Setback
- 20' Parking Setback
- Proposed Security Fence
- Proposed Water Line
- Proposed Storm Sewer
- Proposed Sanitary Sewer
- Proposed Sanitary Manhole
- Proposed Storm Structure
- Proposed Fire Hydrant

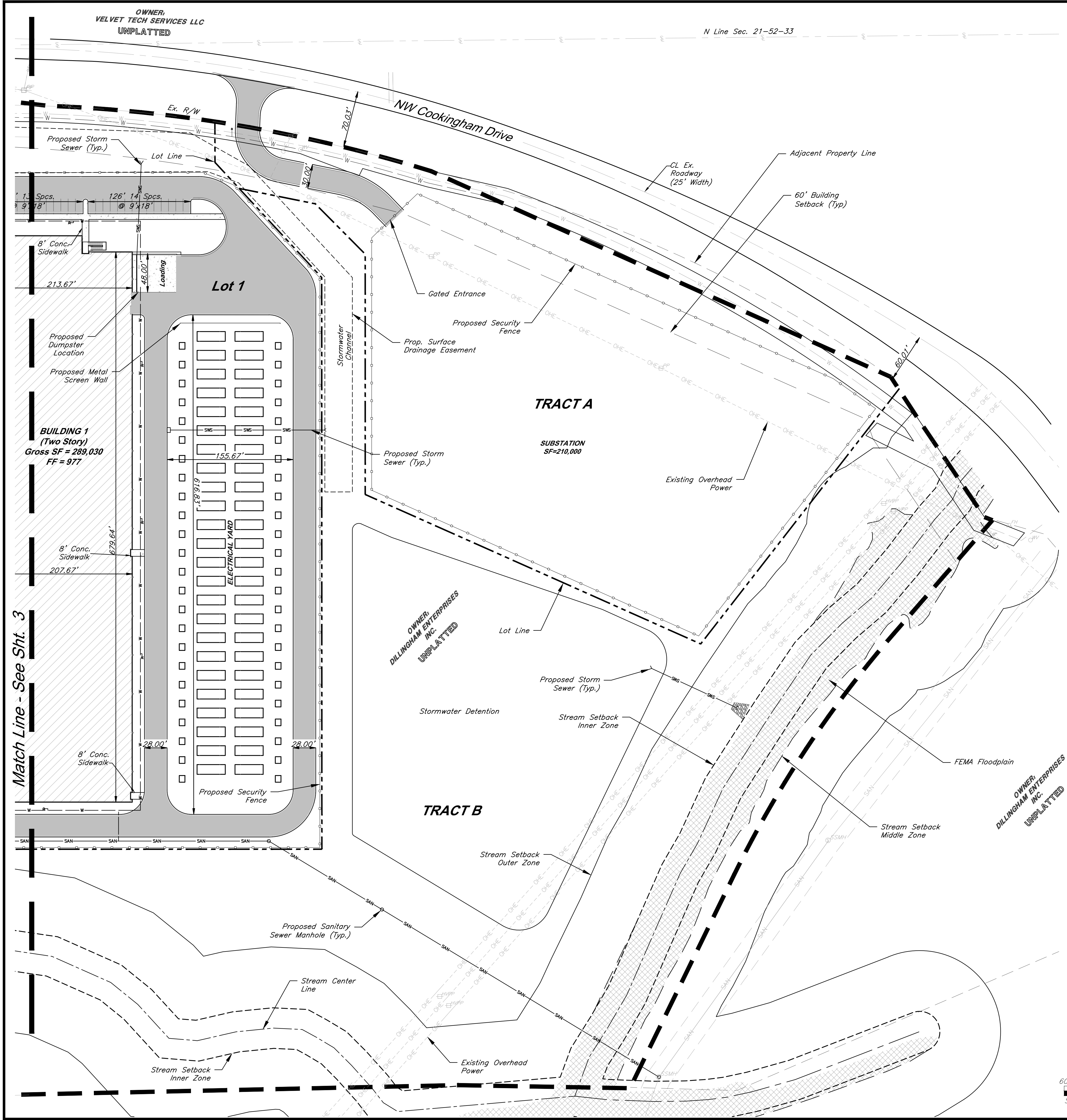
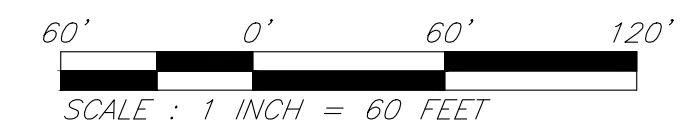

Site Plan

C:\15410.1\Civil 3D\Production Drawings\Resoning & Preliminary Development Plans\15410.1\10200.dwg Layout: 5 Landscape Plan -- Friday, April 19, 2024, 1:48pm -- Copyright 2024, George Butler Associates, Inc. Architect 00212, Professional Engineer 000133, Professional Land Surveyor 000269

Re: Streetscape Plan, Sheet 6

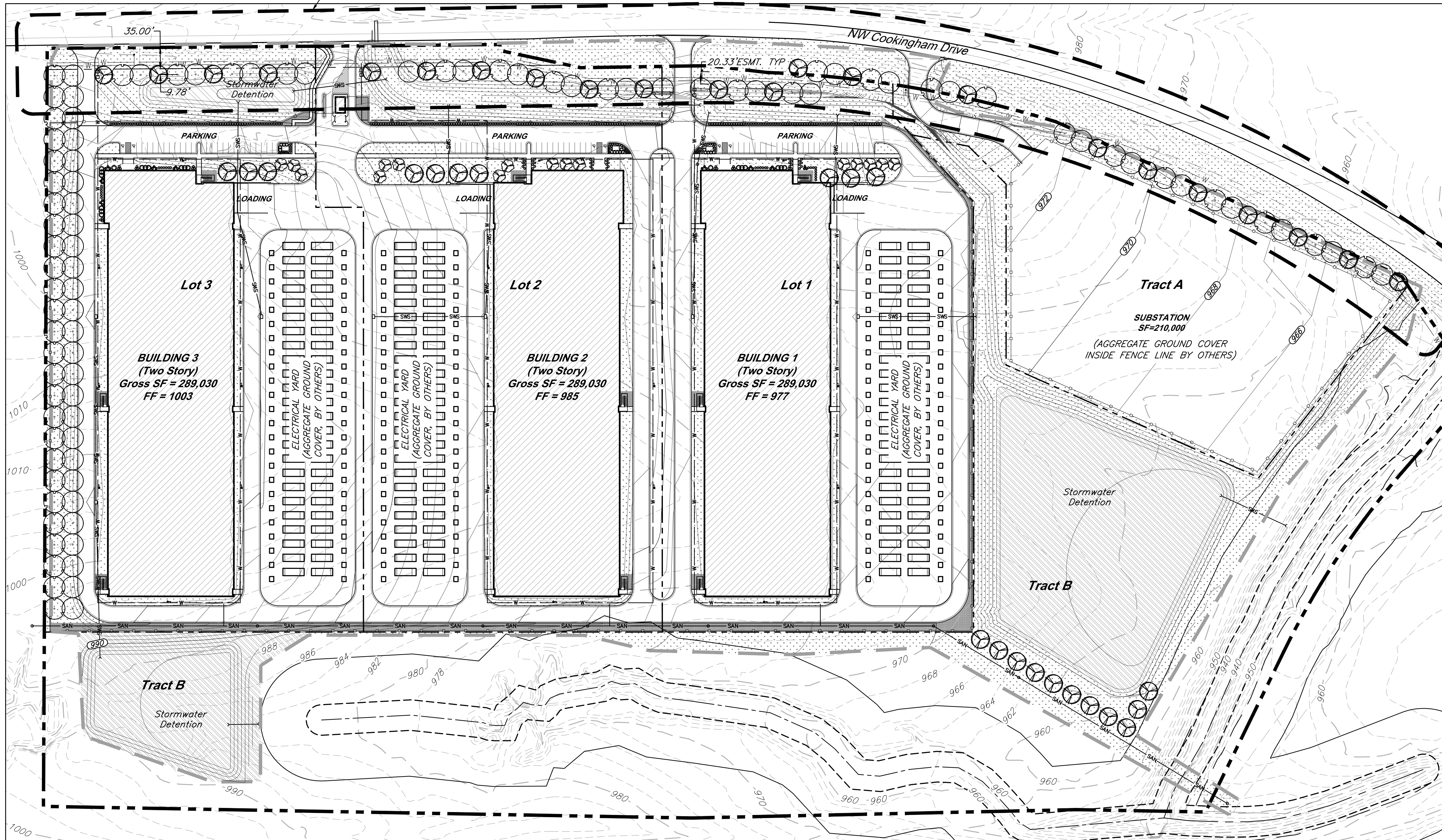

GBA
 9801 Renner Blvd., Ste. 300
 Lenexa, KS 66219
 913.492.0400
 gbateam.com

DATE: 3/15/2024
 DESIGN BY: CEL
 DRAWN BY: DRV/ELS
 PROJECT NO.: 15410.11
 SHEET NUMBER: **5**

Clint Loumaster Professional Engineer License No. PB-2011009651		M2-3 Rezoning - Pre. Development Plan & Pre. Plat COOKINGHAM DEVELOPMENT Kansas City, Missouri	
NO.	DATE	REVISIONS	BY APPROVED
1	4/19/24	City Comments 4/5/2024	ELS

OVERALL PLANT SCHEDULE

SYMBOL	CODE	QTY	BOTANICAL / COMMON NAME
TREES			
	AS	43	Acer saccharum 'John Pair' / Fall Fiesta Maple
	CO	16	Cercis canadensis texensis 'Oklahoma' / Oklahoma Texas Redbud
	PM	48	Platanus x acerifolia 'Morton Circle' / Exclamation Plane Tree
	QS	48	Quercus shumardii / Shumard Oak
SHRUBS			
	HK	27	Hypericum kalmianum 'Deppe' / Sunny Boulevard® St. Johnswort
	IS	130	Ilex glabra 'Shamrock' / Shamrock Holly
	JK	16	Juniperus chinensis 'Kallays Compact' / Kallay Juniper
	JF	20	Juniperus chinensis 'Sea Green' / Sea Green Juniper
	JA	131	Juniperus x pfitzeriana 'Armstrongii' / Armstrong Pfitzer Juniper
	PV	110	Panicum virgatum 'Shenandoah' / Shenandoah Switch Grass
	VN	32	Viburnum opulus 'Nanum' / Dwarf European Cranberrybush
GROUND COVERS			
	DR	45,320 sf	Decorative Landscape Rock
	FG	544,345 sf	Festuca var. Native Mix Oval Sedge - Carex brevior Canada Wild Rye - Elymus canadensis Bottlebrush Sedge - Elymus hystix Tussock Sedge Common Rush Fox Sedge American Sweet Flag
	NM	211,375 sf	

LANDSCAPE REQUIREMENTS (Kansas City, Missouri)

ITEM(S)	REQUIRED	PROVIDED
STREET TREES (88-425-03-C)		
1 TREE PER 30' OF FRONTAGE COOKINGHAM DRIVE (2,561 L.F.)	2,561 L.F. / 30 = 85 TREES	67 TREES
PARKING LOT SCREENING (88-425-05-B)		
3' HT. CONT. EVERGREEN HEDGE	3' HT. CONT. EVERGREEN HEDGE AT PARKING	PROVIDED PER PLANS
INTERIOR PARKING LOT LANDSCAPE (88-425-06)		
TOTAL PROPOSED PARKING = 81 SPACES		
35 S.F. LANDSCAPE AREA PER 1 PARKING SPACE	LANDSCAPE AREA REQUIRED = 2,835 S.F.	5,332 S.F.
1 TREE PER 5 PARKING SPACES	TREES REQUIRED = 16	26 TREES
1 SHRUB PER PARKING SPACE	SHRUBS REQUIRED = 81	205 SHRUBS
GENERAL LANDSCAPE (88-425-04)		
1 TREE PER 5,000 S.F. OF BLDG. COVERAGE BUILDING COVERAGE = 433,386 S.F.	433,386 S.F. / 5,000 = 86.6 TREES	87 TREES PROVIDED
SCREENING OF MECH, UTIL, TRASH (88-425-08-A)		
DUMPSTERS, CONTAINERS, UTILITIES SCREENED FROM PUBLIC VIEW		DUMPSTERS AND TRASH WILL BE CONTAINED WITHIN BUILDING

INTERIOR PARKING LOT LANDSCAPE SCHEDULE (88-425-06)

SYMBOL	CODE	QTY	BOTANICAL / COMMON NAME	SIZE	CONTAINER
TREES					
	AS	10	Acer saccharum 'John Pair' / Fall Fiesta Maple	2.5" Cal.	B&B
	CO	16	Cercis canadensis texensis 'Oklahoma' / Oklahoma Texas Redbud	2" Cal.	
SHRUBS					
	HK	27	Hypericum kalmianum 'Deppe' / Sunny Boulevard® St. Johnswort		
	JK	16	Juniperus chinensis 'Kallays Compact' / Kallay Juniper		
	JF	20	Juniperus chinensis 'Sea Green' / Sea Green Juniper		
	PV	110	Panicum virgatum 'Shenandoah' / Shenandoah Switch Grass		
	VN	32	Viburnum opulus 'Nanum' / Dwarf European Cranberrybush		

PARKING LOT SCREENING SCHEDULE (88-425-05-B)

SYMBOL	CODE	QTY	BOTANICAL / COMMON NAME
SHRUBS			
	IS	130	Ilex glabra 'Shamrock' / Shamrock Holly
	JA	131	Juniperus x pfitzeriana 'Armstrongii' / Armstrong Pfitzer Juniper

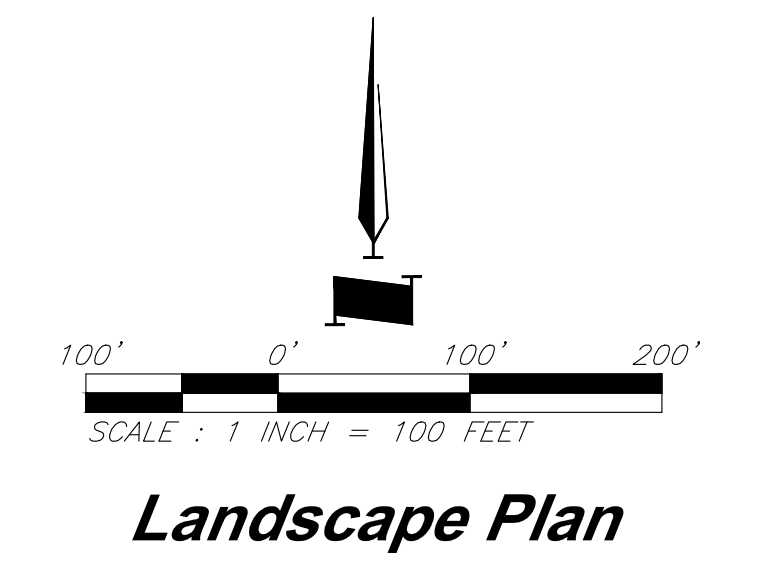

C:\15410.1\Civil 3D\Production Drawings\Rezoning & Preliminary Development Plans\15410.1\10200.dwg Layout: 6 Street Tree Plan -- Friday April 19, 2024, 1:48pm -- Copyright 2024, George Butler Associates, Inc. Architect: 00212, Professional Engineer: 000133, Professional Land Surveyor: 000269

GBA

9801 Renner Blvd., Ste. 300
Lenexa, KS 66219
913.492.0400
gbateam.com

DATE: 3/15/2024
DESIGN BY: CEL
DRAWN BY: DRV/ELS
PROJECT NO.: 15410.11

SHEET NUMBER

6

Clint Loumaster
Professional Engineer
License No. PB-2011009651

M2-3 Rezoning - Pre. Development Plan & Pre. Plat
COOKINGHAM DEVELOPMENT
Kansas City, Missouri

NO.	DATE	REVISIONS	BY	APPROVED
1	4/19/24	City Comments 4/5/2024	ELS	

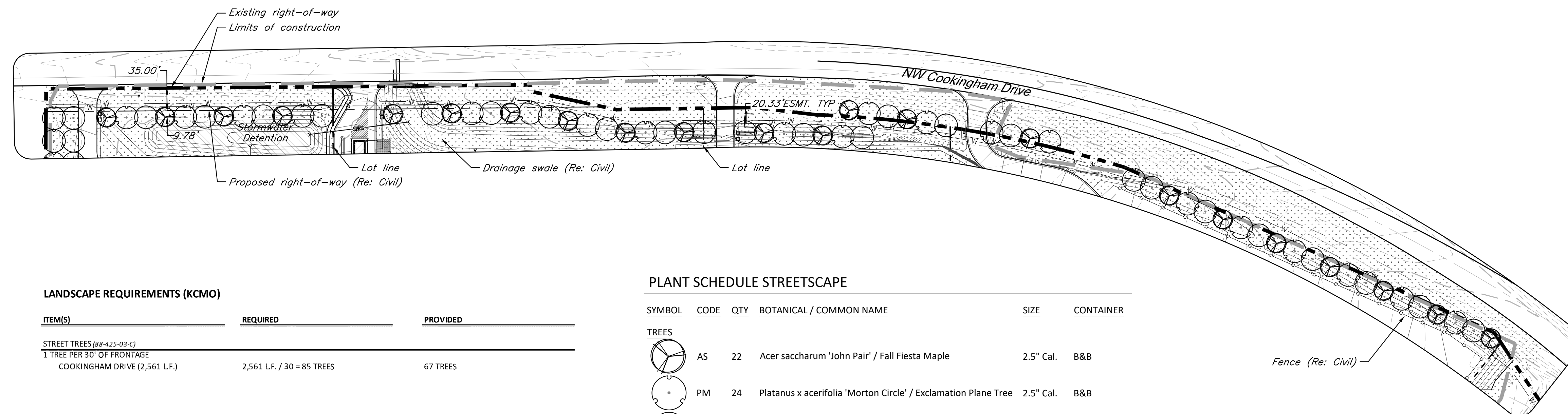

LANDSCAPE REQUIREMENTS (KCMO)

ITEM(S)	REQUIRED	PROVIDED
STREET TREES (88-425-03-C)		
1 TREE PER 30' OF FRONTAGE		
COOKINGHAM DRIVE (2,561 LF.)	2,561 LF. / 30 = 85 TREES	67 TREES

PLANT SCHEDULE STREETSCAPE

SYMBOL	CODE	QTY	BOTANICAL / COMMON NAME	SIZE	CONTAINER
TREES					
	AS	22	Acer saccharum 'John Pair' / Fall Fiesta Maple	2.5" Cal.	B&B
	PM	24	Platanus x acerifolia 'Morton Circle' / Exclamation Plane Tree	2.5" Cal.	B&B
	QS	24	Quercus shumardii / Shumard Oak	2.5" Cal.	B&B

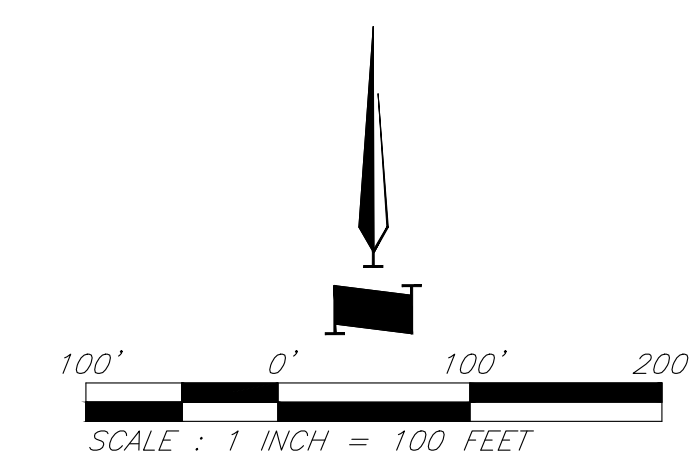

Street Tree Plan

C:\15410.1\Civil 3D\Production Drawings\Resoning & Preliminary Development Plans\15410.1\10200.dwg Layout: 7 Planting Details --- Friday, April 19, 2024, 1:48pm --- Copyright 2024, George Butler Associates, Inc. Architect 00212, Professional Engineer 000133, Professional Land Surveyor 000269

LANDSCAPE NOTES:

- FIELD VERIFY UTILITIES SHOWN ON PLANS PRIOR TO WORK COMMENCEMENT. INFORMATION SHOWN ON PLAN IS FROM AVAILABLE INFORMATION AND ALL LOCATIONS SHOWN SHOULD BE CONSIDERED APPROXIMATE. THE CONTRACTOR AGREES TO BE FULLY RESPONSIBLE FOR ANY AND ALL DAMAGE TO UTILITIES MADE FROM CONSTRUCTION ACTIVITY. IMMEDIATELY NOTIFY PROJECT LANDSCAPE ARCHITECT AND ENGINEER IF DISCREPANCIES ARISE.
- COMPLETE REQUIRED LANDSCAPING FOR THE ENTIRE SITE IN CONFORMANCE TO THE PLANS AND SPECIFICATIONS, INCLUDING BUT NOT LIMITED TO: SEEDED AREAS, SODDED AREAS, SHRUB BEDS, AND SITE CLEAN-UP.
- VERIFY QUANTITIES PRIOR TO COMMENCING WORK. REPORT DISCREPANCIES TO THE LANDSCAPE ARCHITECT. PLANT MATERIAL TO BE SPACED AS SHOWN, UNLESS OTHERWISE NOTED.
- PLANT MATERIAL SHALL COMPLY WITH ALL SIZING AND GRADING STANDARDS OF LATEST EDITION OF AMERICAN STANDARD FOR NURSERY STOCK (A.S.N.S.) LATEST EDITION PUBLISHED BY (ANLA) ANSI 260.1. THIS IS A REPRESENTATIVE GUIDELINE SPECIFICATION ONLY AND WILL CONSTITUTE MINIMUM QUALITY REQUIREMENTS FOR THE PLANT MATERIAL.
- THE OWNER RESERVES THE RIGHT TO SUBSTITUTE PLANT MATERIAL, TYPE, SIZE AND/OR QUANTITY. LARGER SIZED PLANT MATERIALS OF THE SPECIES LISTED MAY BE USED IF THE STOCK CONFORMS TO A.S.N.S. VEGETATION SUBSTITUTIONS SHALL BE APPROVED BY PROJECT LANDSCAPE ARCHITECT. SUBSTITUTIONS MADE WITHOUT WRITTEN APPROVAL WILL BE REPLACED WITH APPROVED SELECTIONS AT CONTRACTOR'S COST.
- DISTURBED AREAS DUE TO CONSTRUCTION ACTIVITIES NOT IDENTIFIED ON THESE PLANS SHALL BE REPAIRED AND RESTORED TO ORIGINAL OR BETTER CONDITIONS AT CONTRACTOR'S COST. SOD WITH A TURF-TYPE TALL FESCUE BLEND SHALL BE PROVIDED FOR AREAS NOT DESIGNATED AS BEDS & PAVEMENT.
- CONTRACTOR SHALL COMPLY WITH APPLICABLE CODES AND ORDINANCES REGARDING LANDSCAPING. REFER TO SPECIFICATIONS FOR PLANT MATERIAL, SOILS, AND INSTALLATION METHODS.
- INSTALL PLANT MATERIAL IN ACCORDANCE WITH A.S.N.S. STANDARDS.
- INSTALL FINISHED GRADES OF SOD, LANDSCAPE BEDS, AND MULCH 1" BELOW ABUTTING PAVEMENT SURFACES TO ALLOW UNINHIBITED DRAINAGE TO NON-PAVEMENT SURFACES.
- REMOVE ALL TWINE, WIRE, AND BURLAP FROM TREE AND SHRUB ROOT BALLS. REMOVE ALL PLASTIC WRAP, FABRIC ROPE, ROT PROOF WRAP, AND PLANT IDENTIFICATION TAGS.
- TREES SHALL NOT BE PLANTED CLOSER THAN EIGHT HORIZONTAL FEET OF UNDERGROUND UTILITIES UNLESS OTHERWISE NOTED OR PER PLANS. MODIFICATIONS TO TREE PLACEMENT SHALL BE COORDINATED WITH THE LANDSCAPE ARCHITECT AND CAN BE SUBJECT TO CITY REVIEW AND APPROVAL. CONTRACTOR IS RESPONSIBLE FOR UNAPPROVED RELOCATION(S) OR MODIFICATION(S) TO TREE LOCATIONS.
- PROVIDE NATURAL TOPSOIL THAT IS FERTILE, FRIABLE, WITHOUT MIXTURE OF SUBSOIL MATERIALS, AND OBTAINED FROM A WELL DRAINED, AVAILABLE SITE. IT SHALL NOT CONTAIN SUBSTANCES WHICH MAY BE HARMFUL TO PLANT GROWTH. TOPSOIL SHALL BE SCREENED AND FREE FROM CLAY, LUMPS, STONES, ROOTS, PLANTS, OR SIMILAR SUBSTANCES 1" OR MORE IN DIAMETER, DEBRIS, OR OTHER OBJECTS WHICH MIGHT BE A HINDRANCE TO PLANTING OPERATIONS. TOPSOIL SHALL CONTAIN AT LEAST 4-6% ORGANIC MATTER BY WEIGHT AND HAVE A PH RANGE OF 5.5 TO 7.0.

- PLANT MATERIAL TO BE GUARANTEED FOR ONE (1) YEAR FROM THE DATE OF SUBSTANTIAL COMPLETION AND ACCEPTANCE. PLANT MATERIALS SHALL BE A ONE-TIME-REPLACEMENT AND RECORDS KEPT BY THE LANDSCAPE CONTRACTOR FOR ALL REPLACEMENTS.
- PLANT MATERIAL SHALL BE OF EXCELLENT QUALITY, FREE OF DISEASE & INFESTATION-TRUE TO TYPE, VARIETY, SIZE SPECIFIED, & FORM PER ANSI STANDARDS.
- WATER-IN EACH PLANT IMMEDIATELY FOLLOWING INSTALLATION AND CONTINUE WATERING ROUTINE UNTIL SUBSTANTIAL PROJECT COMPLETION. CONTRACTOR IS REQUIRED TO COORDINATE WATERING REQUIREMENTS TO THE OWNER THEREAFTER.
- ALL WORK SHALL BE COORDINATED WITH THE WORK OF OTHER TRADES.
- THE OWNER'S REPRESENTATIVE RESERVES THE RIGHT TO REJECT ANY PLANT MATERIAL NOT CONFORMING TO THE SPECIFICATIONS.
- THE LANDSCAPE CONTRACTOR SHALL TEST PROPOSED PLANTING AREAS FOR SOIL NUTRIENT DEFICIENCIES AND UNDESIRABLE SOIL TEXTURE AND STRUCTURE. BASED ON THE RESULTS OF THIS TESTING, THE LANDSCAPE CONTRACTOR SHALL PROVIDE AND INCORPORATE SOIL CONDITIONING MATERIALS (IE: FERTILIZER, SAND, COMPOST, ETC.) AS NECESSARY TO DEVELOP A PLANT GROWTH MEDIUM OF ADEQUATE FERTILITY, STRUCTURE, AND TEXTURE FOR THE ESTABLISHMENT OF LANDSCAPE MATERIALS. PEAT IS NOT ACCEPTABLE.
- THE LANDSCAPE CONTRACTOR SHALL REMOVE FROM THE SITE ALL ROCK GREATER THAN 1-INCH AND ALL DEBRIS IN THE AREAS OF PROPOSED NEW PLANTINGS.
- DAMAGED TURF AREAS ADJACENT TO PLANTING AREAS SHALL BE RESTORED AND SODDED TO MATCH EXISTING ADJACENT TOPOGRAPHY AND TURF TYPE.
- PLANTING SCHEDULE:
 TREE PLANTING: MARCH 15 - JUNE 15 OR SEPTEMBER 15 - DECEMBER 31
 SHRUB PLANTING: APRIL 15 - JUNE 15 OR AUGUST 15 - OCTOBER 15
 SOD/SEED PLANTING: MARCH 15 - JUNE 15 OR SEPTEMBER 15 - DECEMBER 1
- ALL PLANTING METHODS SHALL COMPLY WITH CITY OF KANSAS CITY, MO STANDARDS.

 9801 Renner Blvd., Ste. 300 Lenexa, KS 66219 913.492.0400 gbateam.com		DATE: 3/15/2024 DESIGN BY: CEL DRAWN BY: DRV/ELS PROJECT NO.: 15410.11 SHEET NUMBER: 7	
		Clint Loumaster Professional Engineer License No. PB-2011009651	
M2-3 Rezoning - Pre. Development Plan & Pre. Plat COOKINGHAM DEVELOPMENT Kansas City, Missouri		REVISIONS City Comments 4/5/2024	
NO.	DATE	BY	APPROVED
1	4/19/24	ELS	

PLANTING BED INSTALLATION NOTES:

- ALL PLANTATION BEDS SHALL BE AMENDED WITH 1 CUBIC YARD OF COTTON BOLL COMPOST PER 1000 SQUARE FEET. FILL COTTON BOLL INTO SOIL TO A 6" DEPTH. A 10-10-10 FERTILIZER SHALL BE SPREAD OVER ALL PLANTING AREAS PRIOR TO PLANTING, AT A RATE OF 50 POUNDS PER 2000 SQ. FT.
- AFTER PLANTING HAVE BEEN INSTALLED, ALL PLANTING BEDS SHALL BE TREATED WITH DACTHAL PRE-EMERGENT HERBICIDE PRIOR TO MULCH OR ROCK APPLICATION.
- PLANT PIT BACKFILL FOR SHRUBS SHALL BE 25% COTTON BOLL COMPOST AND 25% TOP SOIL AND 50% EXISTING SOIL. TOP SOIL SHALL BE NATURAL FERTILE, FRIABLE SOIL POSSESSING CHARACTERISTICS OF REPRESENTATIVE PRODUCTIVE SOILS IN THE AREA. SOIL SHALL NOT BE EXCESSIVELY ACID, ALKALINE OR TOXIC THAT MAY BE HARMFUL TO PLANT GROWTH. ALSO, FREE OF CLAY LUMPS, STONES, STUMPS, ROOTS OR SUBSTANCE 2" OR MORE IN DIAMETER.
- PLANTING TABLETS: INSTALL MANUFACTURER GRO-POWER, INC. PRODUCT: GROPOWER TABLETS, SIZE: 7-GRAM TABLETS, RATE: 1 TABLETS PER 1-GALLON CONTAINER AND 4 TABLETS PER 3-GALLON CONTAINER AND 7 TABLETS PER 5-GALLON CONTAINER.
- PLANTED BED EDGES SHALL BE IN STRAIGHT LINES OR GENTLE FOLLOWING CURVES. SUDDEN CURVES OR SHARP ANGLE SHOULD BE AVOIDED.

TREE NOTES:

- EXCAVATE A PIT WHICH IS AT LEAST TWICE THE DIAMETER OF THE ROOTBALL AND THE SAME DEPTH-NO DEEPER. HANDLE THE TREE BY THE ROOT BALL, NOT THE TRUNK. BE SURE THE ROOT BALL RESTS ON SOLID GROUND.
- BACKFILL WITH PLANTING SOIL.
- SATURATE THE ENTIRE BACKFILL SOIL WITH WATER. ADD MORE SOIL IF NEEDED TO COMPENSATE FOR SETTILING.
- MULCH: COVER SMOOTHED SOIL WITH 2 INCHES OF MULCH. LEAVE GAP NEAR THE TRUNK. KEEP MULCH WEEDED. REPLACE AS NEEDED.
- PRUNE ONLY BROKEN OR BADLY DEFORMED BRANCHES TO RETAIN SHAPE OF THE SPECIES. PRUNE OUT SECONDARY AND COMPETING GROWTH. DO NOT SHEAR. DO NOT CUT LEADER. BEGIN A REGULAR PRUNING PROGRAM THE SECOND YEAR AFTER PLANTING.
- CHAFING GUARDS: REMOVE GUARDS AS SOON AS THE TREE CAN STAND ALONE ABOUT 3 MONTHS OR LONGER IF NEEDED.
- DO NOT ALLOW AIR POCKETS TO FORM WHEN BACKFILLING.
- DO NOT DISTURB ROOT BALL WHEN PLANTING OR STAKING. CRACKED OR OTHERWISE DAMAGED ROOT BALLS SHALL BE REJECTED.
- WATER THOROUGHLY FOLLOWING PLANTING.
- REMOVE EXCESS DEBRIS FORM AROUND ROOT COLLAR/FLARE IS LEVEL OR SLIGHTLY ABOVE (1" MAX) ADJACENT UPHILL GRADE.
- SCARIFY EDGES OF EXCAVATION WHERE SMOOTHED DURING EXCAVATION.
- ALL PLANTING METHODS SHALL COMPLY WITH CITY OF BRANSON STANDARDS.

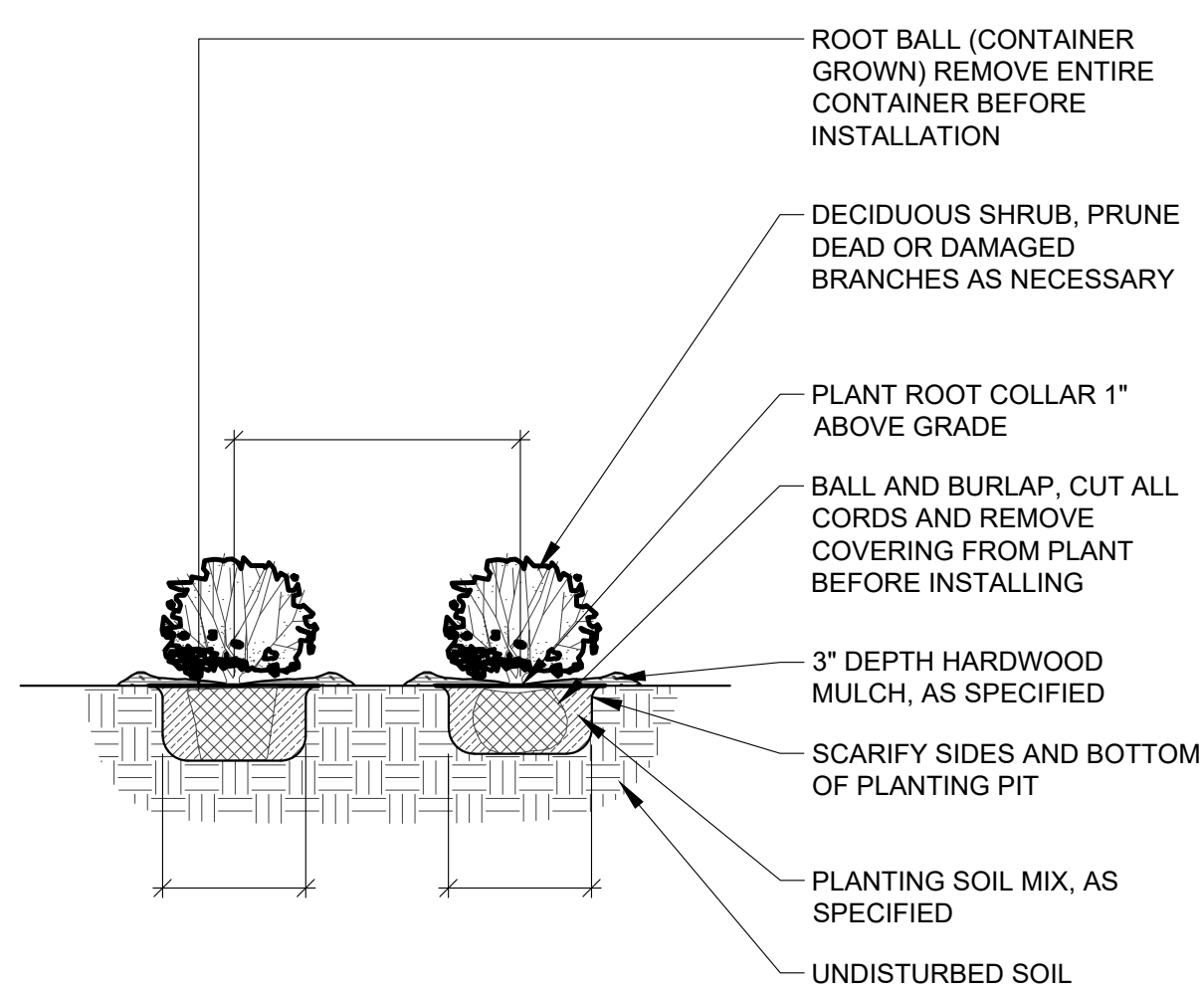

1 SHRUB AND PERENNIAL PLANTING
1/2" = 1'-0"

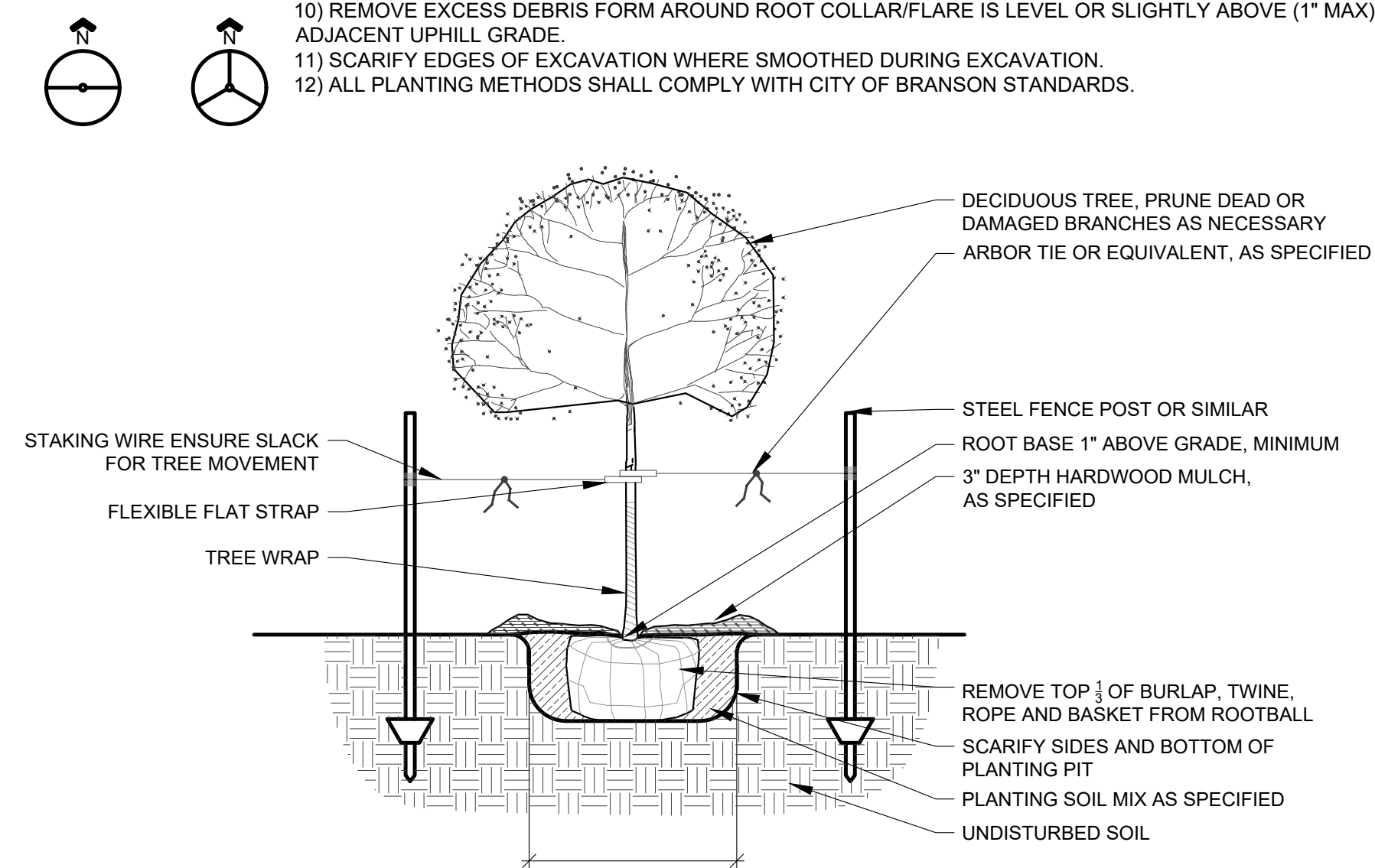

2 DECIDUOUS TREE PLANTING
1/2" = 1'-0"

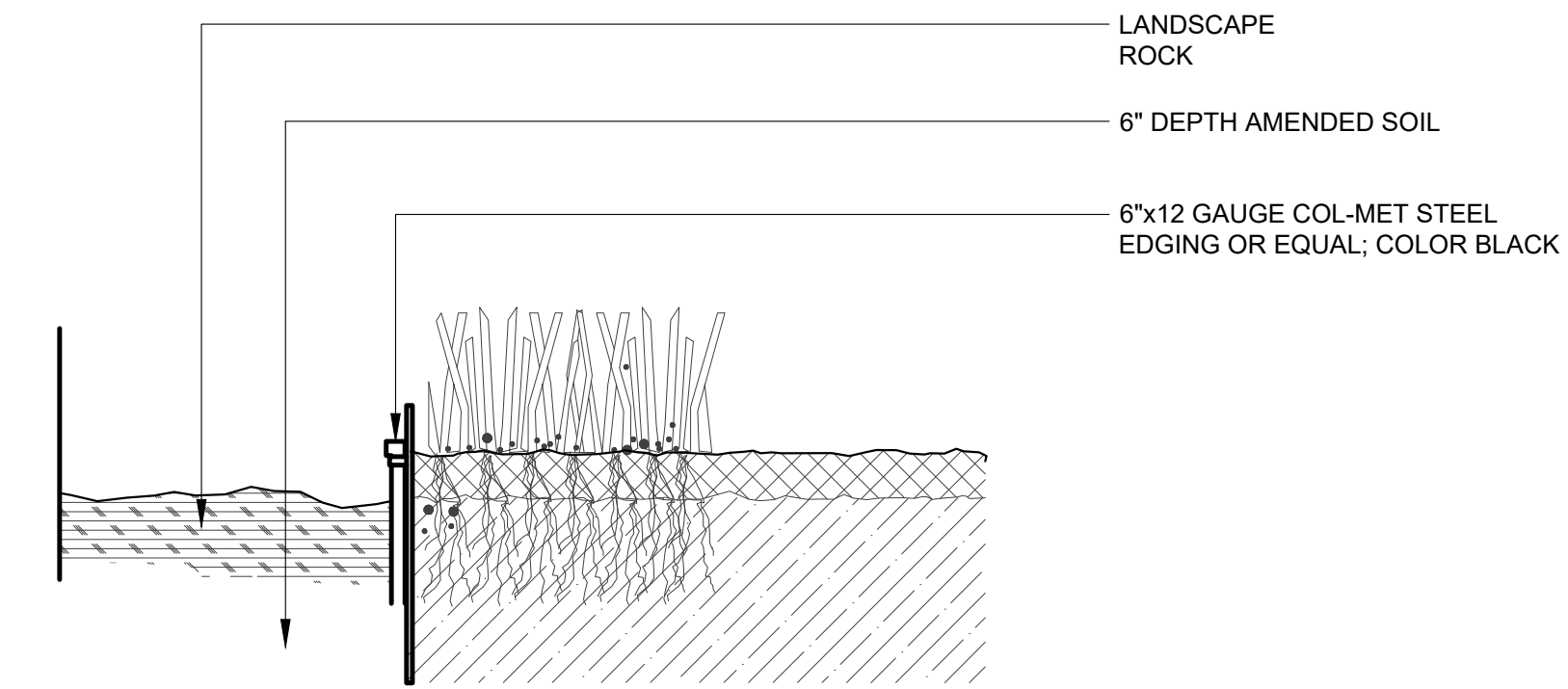

3 METAL EDGING
3" = 1'-0"

C:\15410.1\1\1\1\Civil\3D\Production Drawings\Reasoning & Preliminary Development Plans\15410.1\102700.dwg Layout: B Grading Plan -- Friday, April 19, 2024, 1:49pm -- Copyright 2024, George Butler Associates, Inc. Architect 00212, Professional Engineer 000133, Professional Land Surveyor 000269

OWNER:
VELVET TECH SERVICES LLC
UNPLATTED

GBA
9801 Renner Blvd., Ste. 300
Lenexa, KS 66219
913.492.0400
gbateam.com

DATE: 3/15/2024
DESIGN BY: CEL
DRAWN BY: DRW/ELS
PROJECT NO.: 15410.11
SHEET NUMBER
8

Clint Loumaster
Professional Engineer
License No. PB-2011009651

M2-3 Rezoning - Pre. Development Plan & Pre. Plat
COOKINGHAM DEVELOPMENT
Kansas City, Missouri

NO.	DATE	REVISIONS	BY	APPROVED
1	4/19/24	City Comments 4/5/2024	ELS	

Northland Reformed Church of Kansas City
Project Location
Scale: 1"=1000'

VICINITY MAP
Part of the NW & NE 1/4
Section 21-Township 52-Range 33

Legend

- Proposed Building
- Concrete Sidewalk
- Proposed Asphalt Pavement
- Property Boundary
- Proposed Right-of-Way
- Lot Line
- 60' Building Setback
- 20' Parking Setback
- Proposed Security Fence
- Proposed Water Line
- Proposed Storm Sewer
- Proposed Sanitary Sewer
- Proposed Sanitary Manhole
- Proposed Storm Structure
- Proposed Fire Hydrant
- Proposed Contours
- Existing Contour Major
- Existing Contour Minor
- Existing Tree Line
- TW Top of Wall
- BW Base of Wall

Grading Notes:

- Proposed grading shall comply with ADA requirements.
- Grading within water easement shall maintain 60" minimum cover over existing 24" transmission main. Proposed grading within easement shall be approved by KC Water prior to commencement.

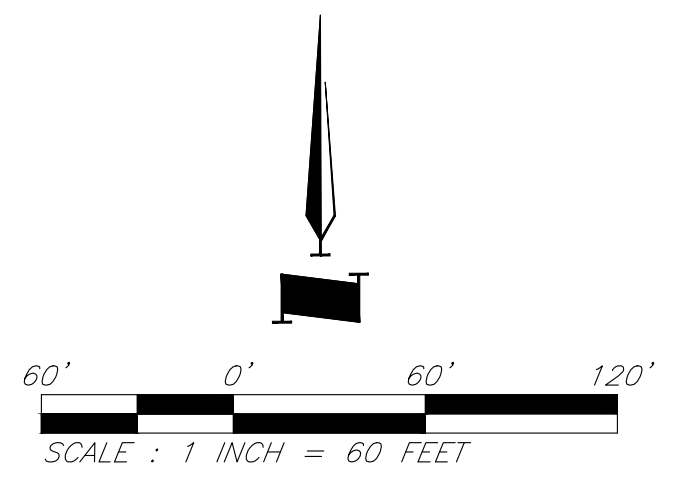
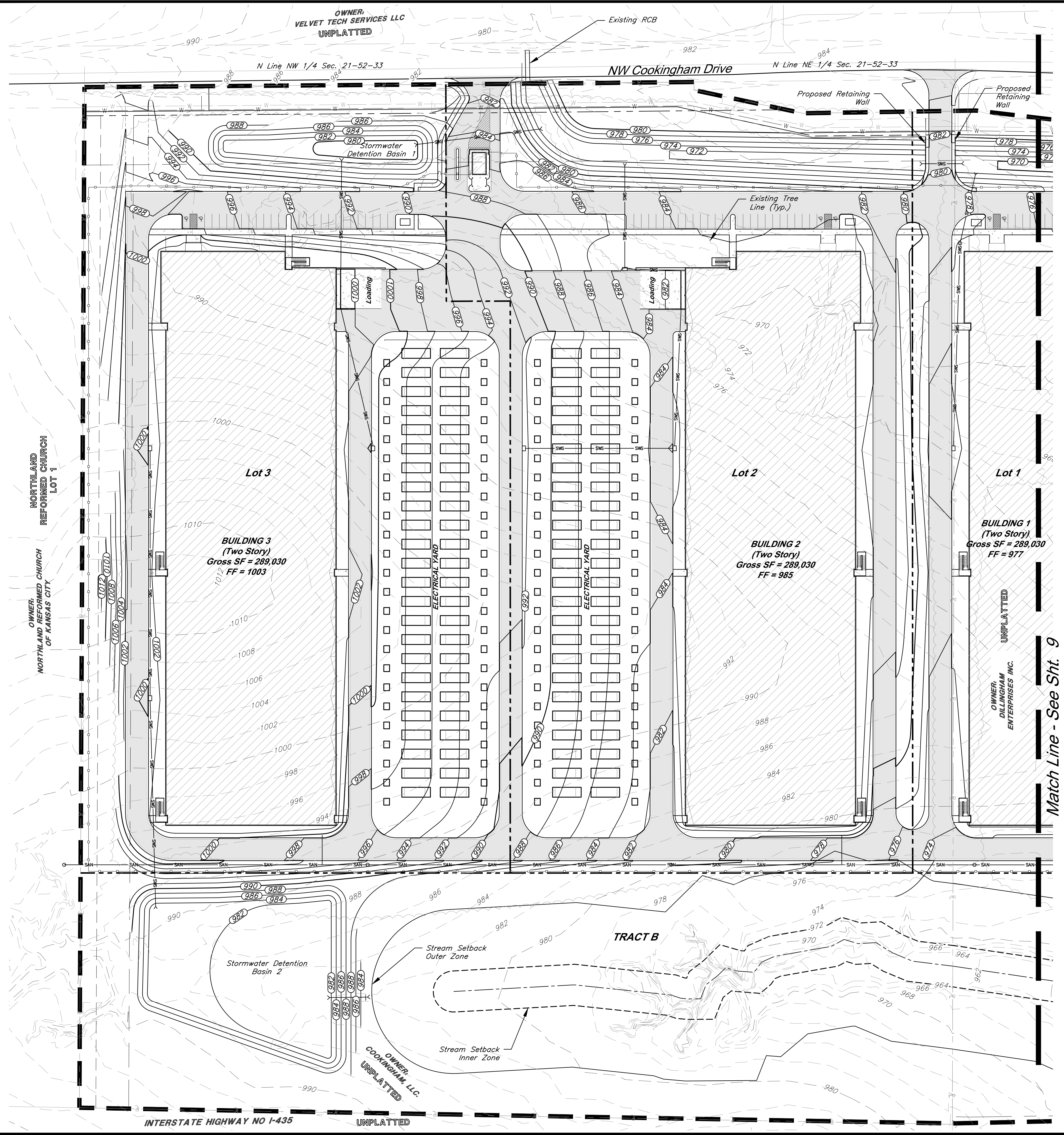

Match Line - See Sht. 9

Grading Plan

C:\15410.1\1\Civil\3D\Production Drawings\Rezoning & Preliminary Development Plans\15410.1\1\02000.dwg Layout: 9 Grading Plan - Friday, April 19, 2024, 1:49pm - Copyright 2024, George Butler Associates, Inc. Architect 00212, Professional Engineer 000133, Professional Land Surveyor 000259

GBA

9801 Renner Blvd., Ste. 300
Lenexa, KS 66219
913.492.0400
gbateam.com

DATE: 3/15/2024
DESIGN BY: CEL
DRAWN BY: DRV/ELS
PROJECT NO.: 15410.11
SHEET NUMBER
9

Clint Loumaster
Professional Engineer
License No. PB-2011009651

M2-3 Rezoning - Pre. Development Plan & Pre. Plat
COOKINGHAM DEVELOPMENT
Kansas City, Missouri

NO.	DATE	REVISIONS	BY	APPROVED
1	4/19/24	City Comments	4/5/2024	ELS

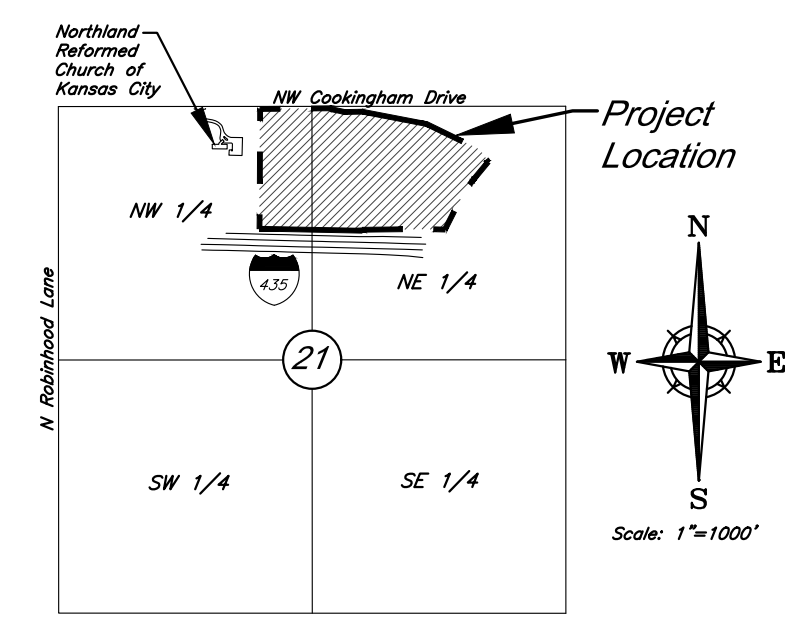

VICINITY MAP
Part of the NW & NE 1/4
Section 21-Township 52-Range 33

Legend

- Proposed Building
- Concrete Sidewalk
- Proposed Asphalt Pavement
- Zone AE FEMA Floodplain
- Property Boundary
- Proposed Right-of-Way
- Lot Line
- 60' Building Setback
- 20' Parking Setback
- Proposed Security Fence
- Proposed Water Line
- Proposed Storm Sewer
- Proposed Sanitary Sewer
- Proposed Sanitary Manhole
- Proposed Storm Structure
- Proposed Fire Hydrant
- Proposed Contours
- Existing Contour Major
- Existing Contour Minor
- Existing Tree Line
- TW Top of Wall
- BW Base of Wall

Grading Notes:

- Proposed grading shall comply with ADA requirements.
- Grading within water easement shall maintain 60" minimum cover over existing 24" transmission main. Proposed grading within easement shall be approved by KC Water prior to commencement.

Floodplain Notes:

According to the Flood Insurance Rate Maps (FIRMs) for the city of Kansas City, Missouri (29095C0061G, dated January 20th, 2017), the site is situated mainly within Zone X, areas determined to be outside the 0.2% annual chance floodplain. A channel on the site contains Zone AE, special flood hazard areas.

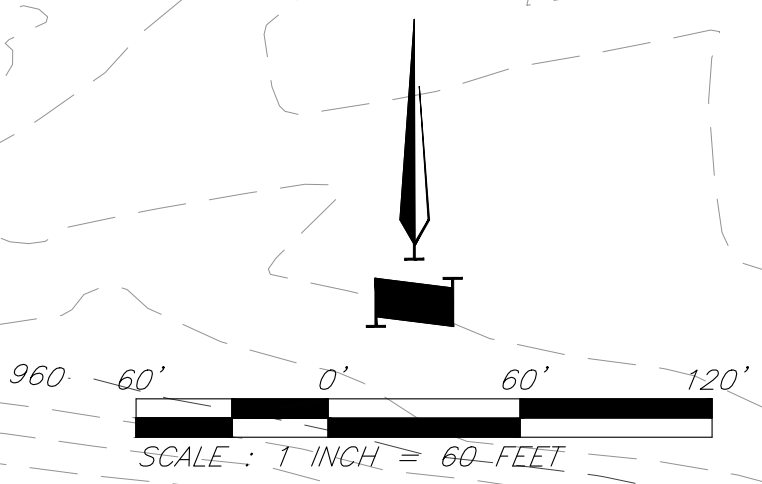
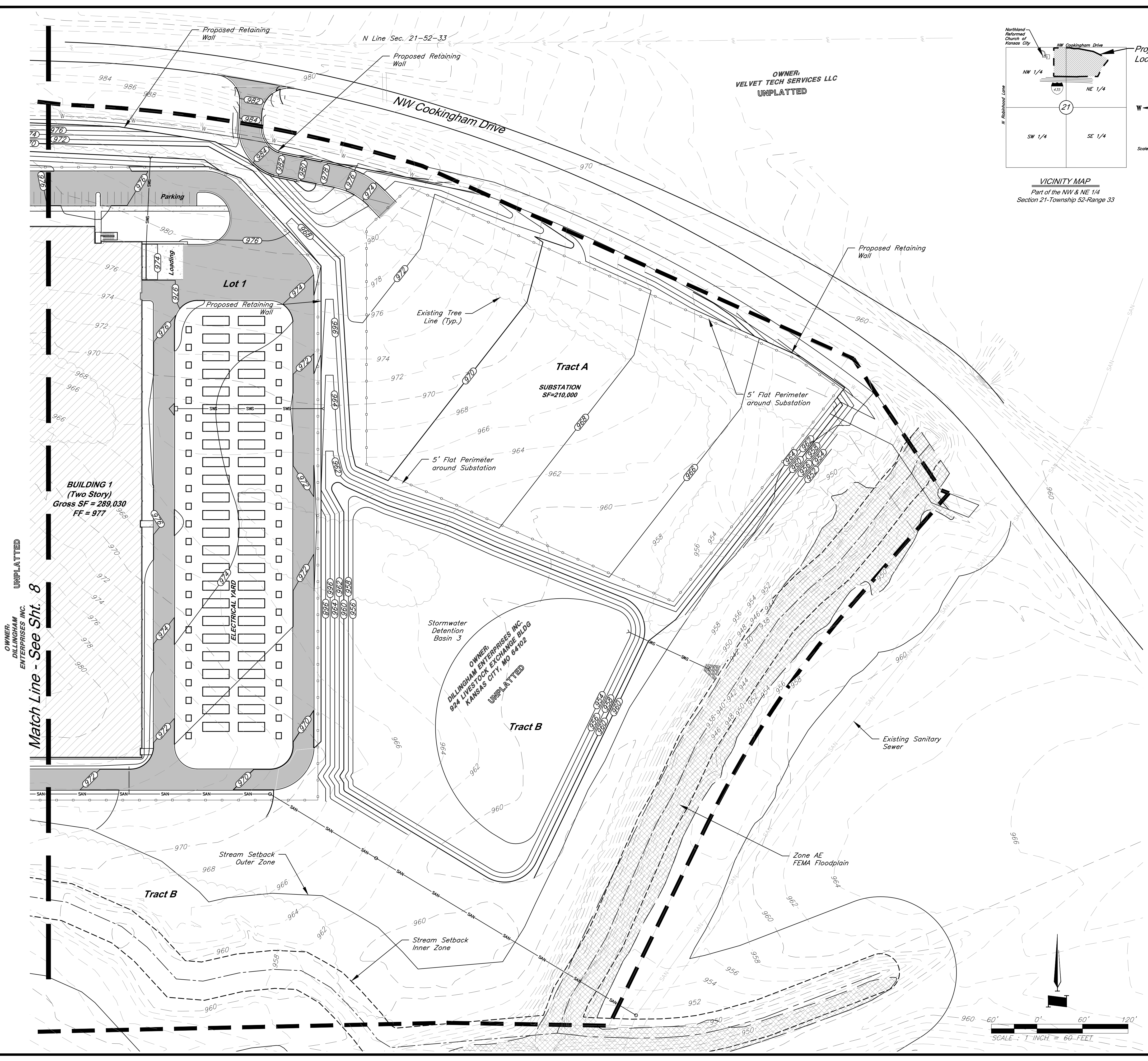

C:\15410.1\1\Production Drawings\Resoning & Preliminary Development Plans\15410.1\1\02000.dwg Layout: 10 Utility Plan -- Friday, April 19, 2024, 1:49pm -- Copyright 2024, George Butler Associates, Inc. Architect 00212, Professional Engineer 000133, Professional Land Surveyor 000269

GBA
 9801 Renner Blvd., Ste. 300
 Lenexa, KS 66219
 913.492.0400
 gbatteam.com

DATE: 3/15/2024
 DESIGN BY: CEL
 DRAWN BY: DRW/ELS
 PROJECT NO.: 15410.11
 SHEET NUMBER: **10**

Clint Loumaster Professional Engineer License No. PB-2011009651		M2-3 Rezoning - Pre. Development Plan & Pre. Plat COOKINGHAM DEVELOPMENT Kansas City, Missouri	
NO.	DATE	REVISIONS	BY
1	4/19/24	City Comments 4/5/2024	ELS

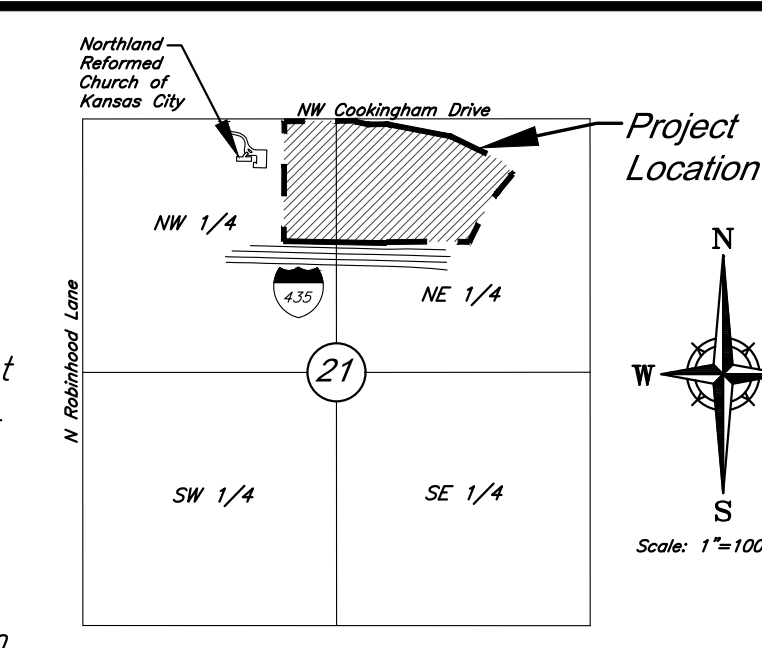

Legend

- Property Boundary
- Proposed Right-of-Way
- Lot Line
- 60' Building Setback
- 20' Parking Setback
- Proposed Security Fence
- Proposed Water Line
- Proposed Storm Sewer
- Proposed Sanitary Sewer
- Proposed Drainage Easement
- Path of Stormwater Conveyance
- Proposed Building
- Concrete Sidewalk
- Proposed Asphalt Pavement
- Proposed Sanitary Manhole
- Proposed Storm Structure
- Proposed Fire Hydrant

- General Notes:**
1. Fire hydrants shall be installed and operable prior to the arrival of any combustible building materials onto the site.
 2. The project shall meet the fire flow requirements as set forth in Appendix B of the International Fire Code 2018.
 3. Required fire department access roads shall be all weather surfaces.
 4. Security gates which span across a fire access road shall provide a means for emergency operation.
 5. Required fire department access roads shall be designed to support a fire apparatus with a gross axle weight of 85,000 pounds.
 6. All access roads must be completed within the first phase of construction.
 7. Public sanitary sewer easements will be located in future work.
 8. Public fire hydrants shall meet maximum 300' spacing along Cookingham Drive.

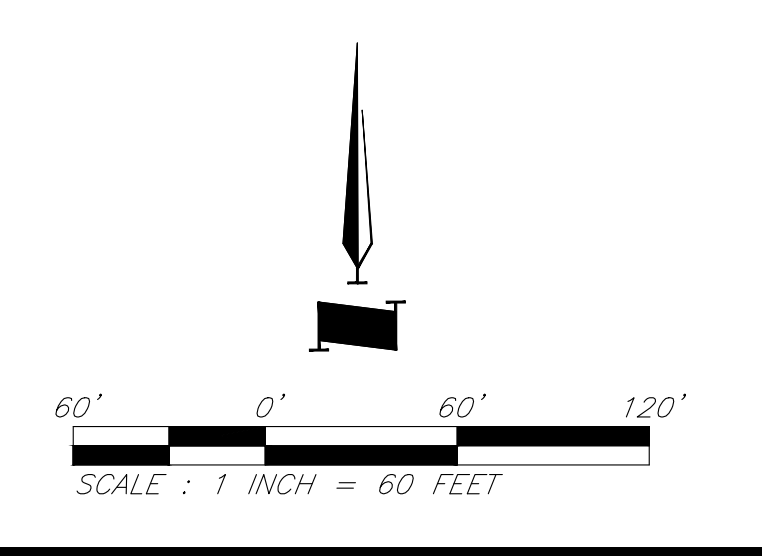
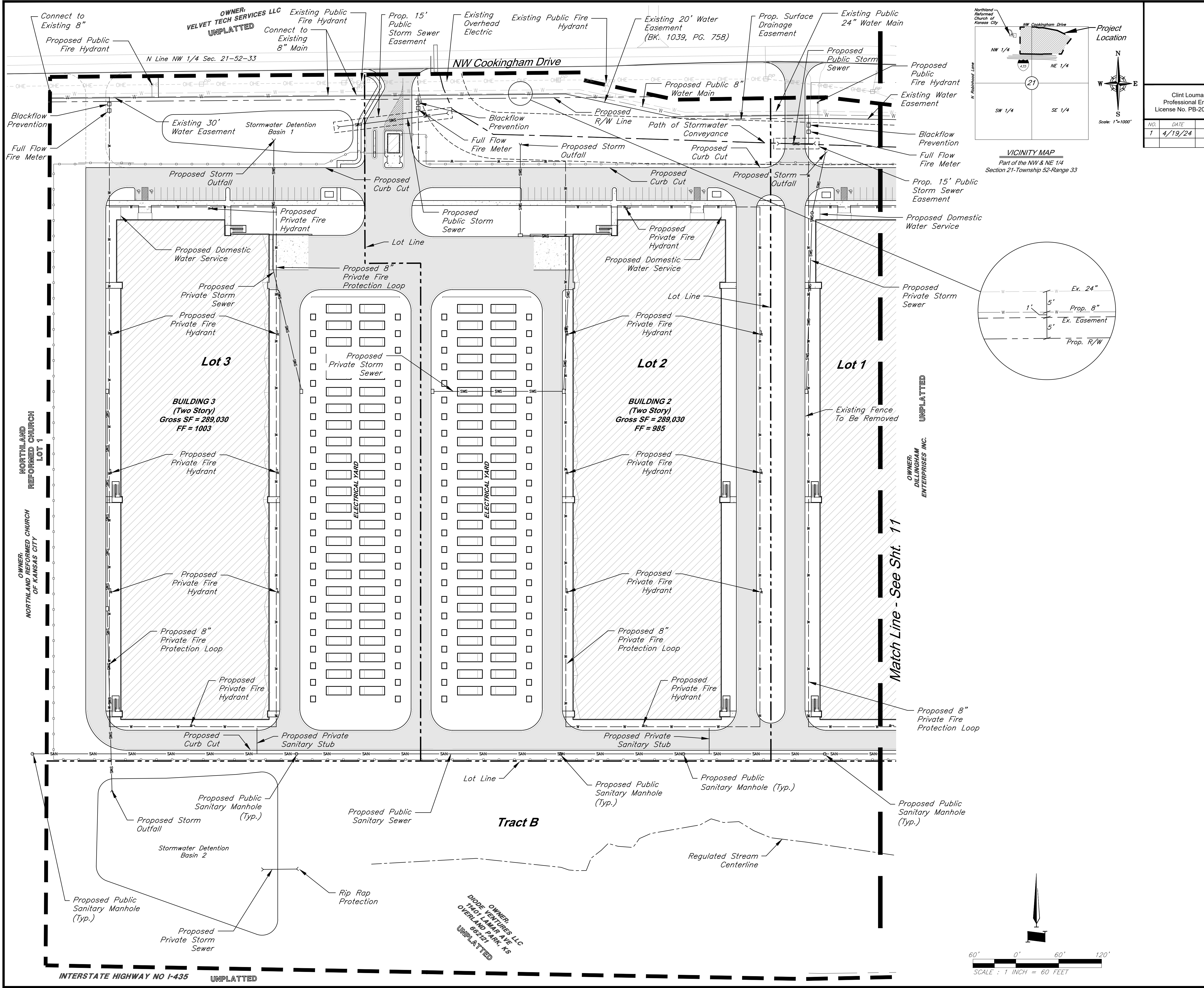

Utility Plan

C:\15410.11\Civil\3D\Production Drawings\Rezonig & Preliminary Development Plans\15410.11\02000.dwg Layout: 11 Utility Plan --- Friday, April 19, 2024, 1:49pm --- Copyright 2024, George Butler Associates, Inc. Architect 00212, Professional Engineer 000133, Professional Land Surveyor 000269

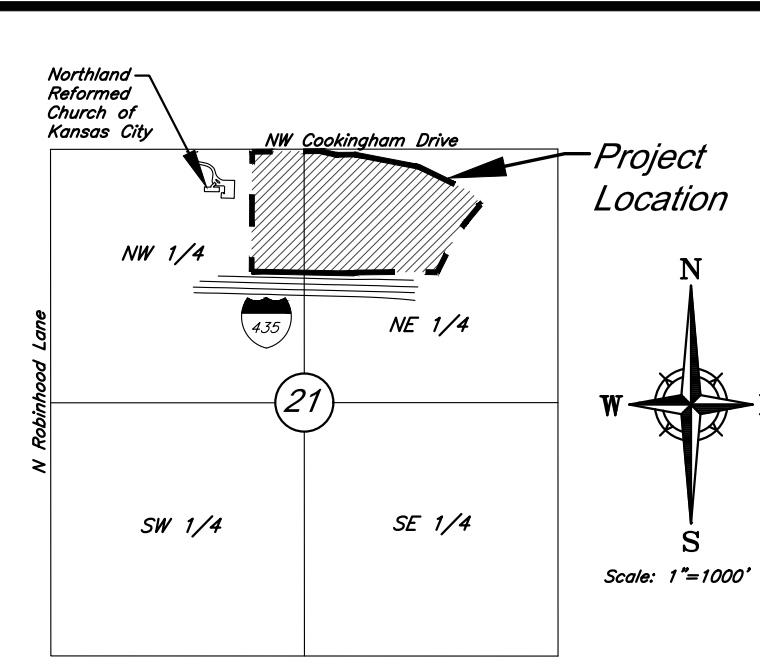
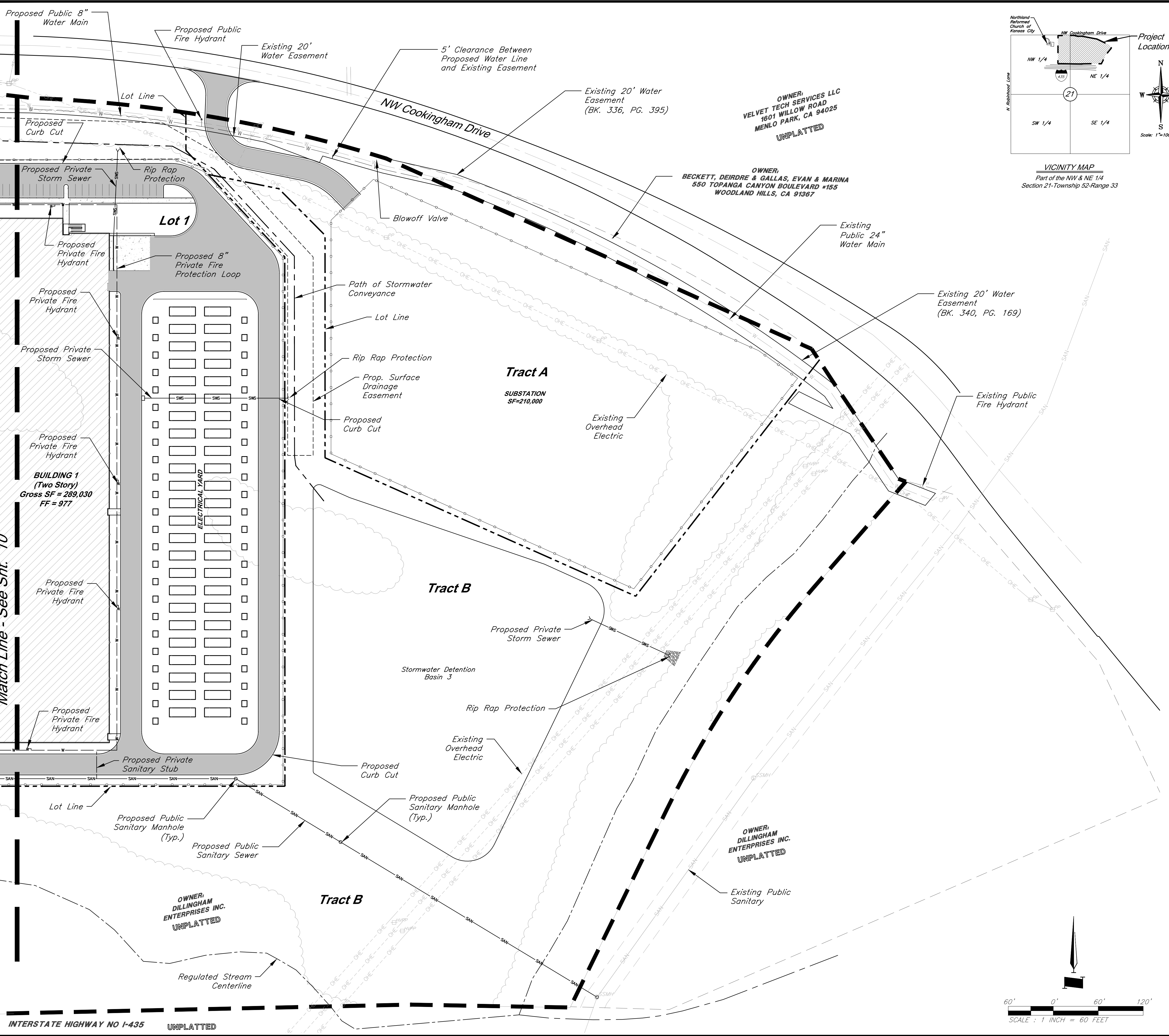

GBA
 9801 Renner Blvd., Ste. 300
 Lenexa, KS 66219
 913.492.0400
 gbateam.com

DATE: 3/15/2024
 DESIGN BY: CEL
 DRAWN BY: DRV/ELS
 PROJECT NO.: 15410.11
 SHEET NUMBER: **11**

Clint Loumaster Professional Engineer License No. PB-2011009651		M2-3 Rezoning - Pre. Development Plan & Pre. Plat COOKINGHAM DEVELOPMENT Kansas City, Missouri	
NO.	DATE	REVISIONS	BY
1	4/19/24	City Comments 4/5/2024	ELS

Legend

- Property Boundary
- Proposed Right-of-Way
- Lot Line
- 60' Building Setback
- 20' Parking Setback
- Proposed Security Fence
- Proposed Water Line
- Proposed Storm Sewer
- Proposed Drainage Easement
- Path of Stormwater Conveyance
- Proposed Building
- Concrete Sidewalk
- Proposed Asphalt Pavement
- Proposed Sanitary Manhole
- Proposed Storm Structure
- Proposed Fire Hydrant

- General Notes:**
1. Fire hydrants shall be installed and operable prior to the arrival of any combustible building materials onto the site.
 2. The project shall meet the fire flow requirements as set forth in Appendix B of the International Fire Code 2018.
 3. Required fire department access roads shall be all weather surfaces.
 4. Security gates which span across a fire access road shall provide a means for emergency operation.
 5. Required fire department access roads shall be designed to support a fire apparatus with a gross axle weight of 85,000 pounds.
 6. All access roads must be completed within the first phase of construction.
 7. Public sanitary sewer easements will be located in future work.
 8. Public fire hydrants shall meet maximum 300' spacing along Cookingham Drive.

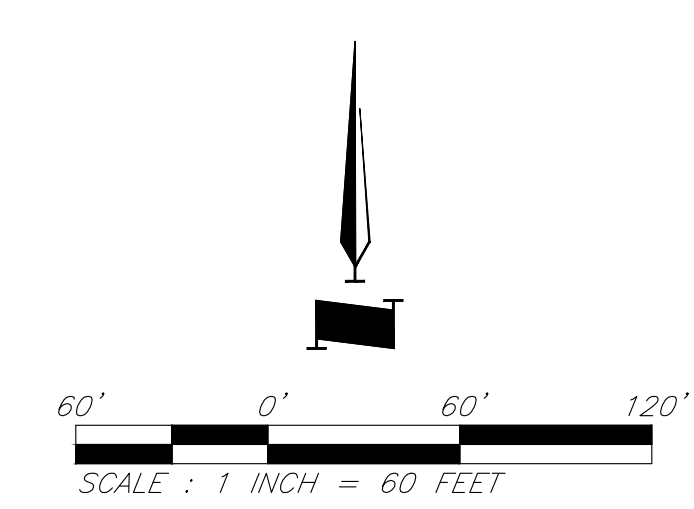

Utility Plan

General Notes:

- No mitigation shall be required if contiguous tree canopy cover is less than one acre.

Tree Removal & Preservation Data Table	
Total Tree Acres on Property	21.25
Total Acres to be Removed	9.43
Total Acres to be Preserved	11.83
Total Acres of Undisturbed Stream Buffer	8.68
Total Acres of Canopy within Buffer	8.93

Planting Summary	
Tree Size (IN)	Quantity
2	16
2.5	139
Total Caliper Inch	379.5

Mitigation Rate Calculation (88-424-07)	
Step 1	9.43 AC
Step 2	0.74 AC
Step 3	0.26 AC
Step 4	39.08 IN
Step 5	-340.42 IN

No further mitigation is required.

Legend

- Proposed Building
- Concrete Sidewalk
- Proposed Asphalt Pavement
- Trees Removed
- Trees Preserved
- Existing Tree Line
- Property Boundary
- Proposed Right-of-Way
- Lot Line
- Proposed Security Fence
- Proposed Water Line
- Proposed Storm Sewer
- Proposed Sanitary Sewer
- Proposed Sanitary Manhole
- Proposed Storm Structure
- Proposed Fire Hydrant

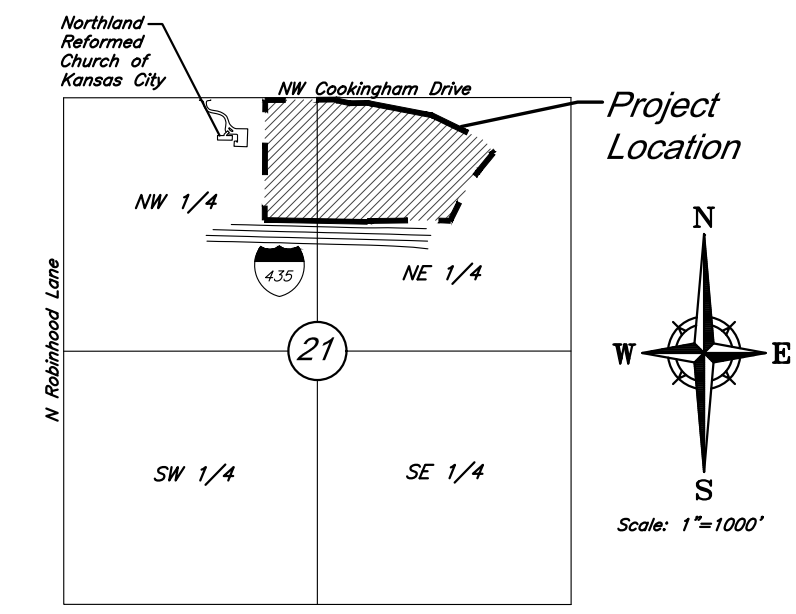

GBA
9801 Renner Blvd., Ste. 300
Lenexa, KS 66219
913.492.0400
gbateam.com

DATE: 3/15/2024
DESIGN BY: CEL
DRAWN BY: DRV/ELS
PROJECT NO.: 15410.11
SHEET NUMBER: 12

Clint Loumaster
Professional Engineer
License No. PB-2011009651

M2-3 Rezoning - Pre. Development Plan & Pre. Plat
COOKINGHAM DEVELOPMENT
Kansas City, Missouri

NO.	DATE	REVISIONS	BY	APPROVED
1	4/19/24	City Comments 4/5/2024	ELS	

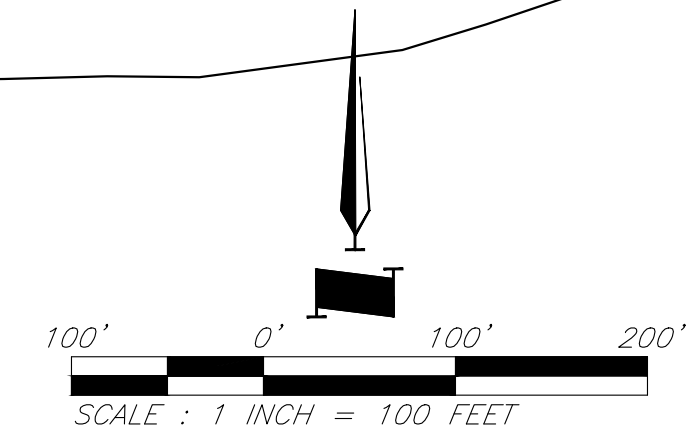
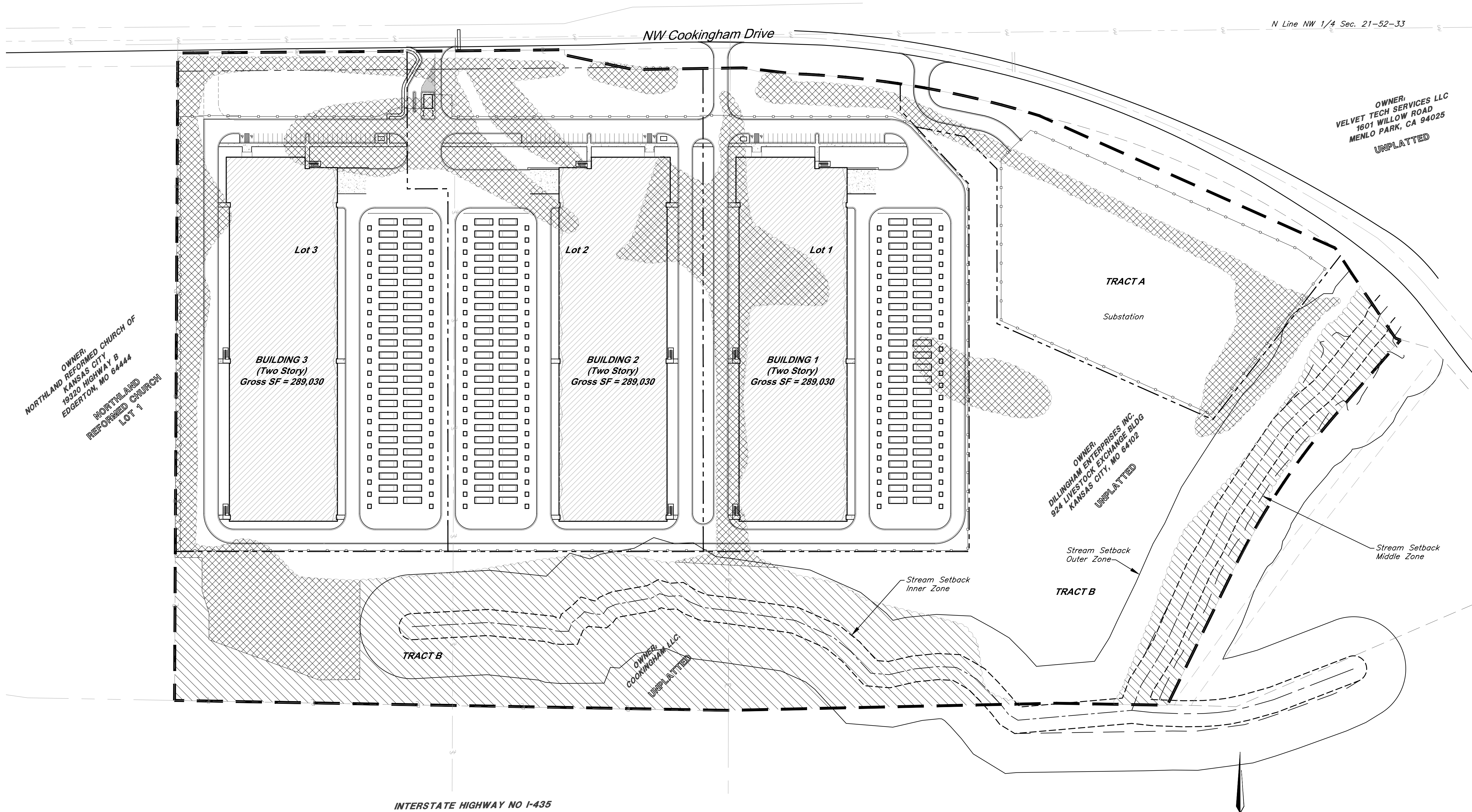

Tree Removal & Tree Preservation Plan

C:\15410.11\Civil\3D\Production Drawings\Rezoning & Preliminary Development Plans\15410.11\22800.dwg Layout: 12 Tree Removal & Tree Preservation Plan - Friday, April 19, 2024, 1:50pm - Copyright 2024, George Beahm, Professional Engineer, 000133, Professional Land Surveyor, 000269

PRELIMINARY PLAT FOR COOKINGHAM DEVELOPMENT

GBA
 9801 Renner Blvd., Ste. 300
 Lenexa, KS 66219
 913.492.0400
 gbateam.com

DATE: 3/15/2024
 DESIGN BY: CEL
 DRAWN BY: DRV/ELS
 PROJECT NO.: 15410.11
 SHEET NUMBER: **13**

Clint Loumaster
 Professional Engineer
 License No. PB-2011009651

M2-3 Rezoning - Pre. Development Plan & Pre. Plat
COOKINGHAM DEVELOPMENT
 Kansas City, Missouri

Legend

- Property Boundary
- Proposed Right-of-Way
- Lot Line
- 60' Building Setback
- 20' Parking Setback
- Proposed Drainage Easement
- Proposed Water Line
- SWS - Proposed Storm Sewer
- SAN - Proposed Sanitary Sewer
- Proposed Sanitary Manhole
- Proposed Storm Structure
- Proposed Fire Hydrant
- Existing Tree Line

SITE DATA per APPLICATION SUBMITTAL REQUIREMENTS
 a) Existing Zoning: AG-R & M2-3
 Proposed Zoning: M2-3

Item	Lot 1		Lot 2		Lot 3		Tract A		Tract B		Total
	Existing	Proposed	Existing	Proposed	Existing	Proposed	Existing	Proposed	Existing	Proposed	
b) Total Land Area (SFT)	449,865	449,865	484,658	484,658	479,404	479,404	218,275	218,275	861,148	861,148	2,493,350
Total Land Area (AC)	10.33	10.33	11.13	11.13	11.01	11.01	5.01	5.01	19.77	19.77	57.24
c) Land Area for Street ROW (SFT)	0	0	0	11,992	0	15,413	0	0	0	0	27,405
Land Area for Street ROW (AC)	0.00	0.00	0.00	0.28	0.00	0.35	0.00	0.00	0.00	0.00	0.63
d) Net Land Area (SFT)	449,865	449,865	472,666	472,666	463,991	463,991	218,275	218,275	861,148	861,148	2,465,945
Net Land Area (AC)	10.33	10.33	10.85	10.85	10.65	10.65	5.01	5.01	19.77	19.77	56.61

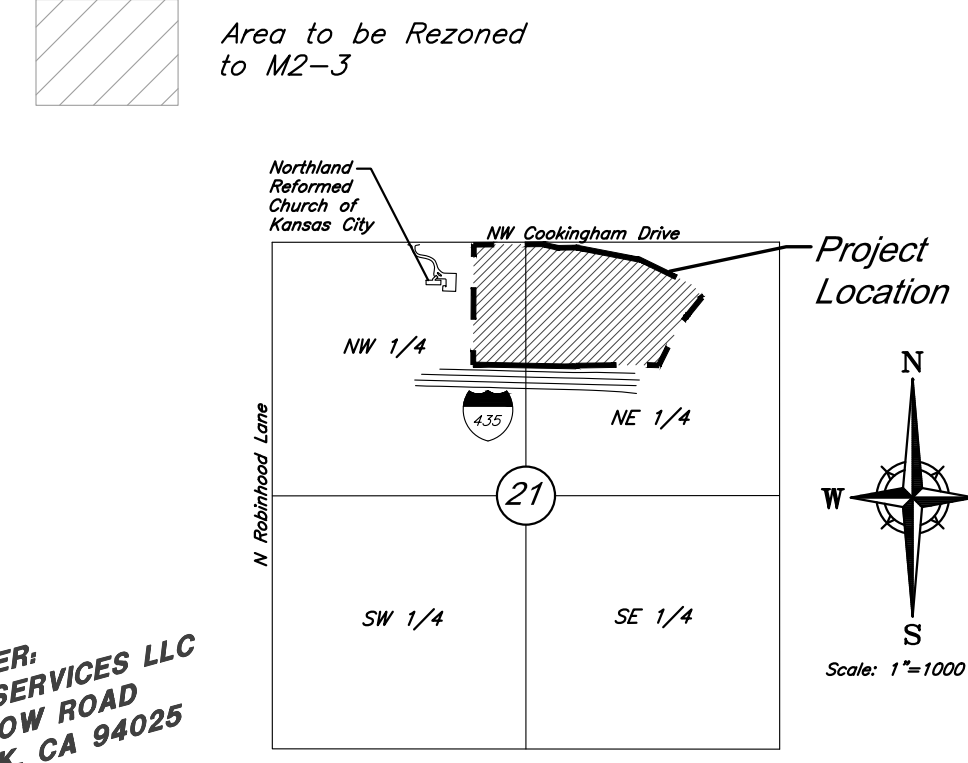

LEGAL DESCRIPTION

ALL THAT PART OF THE EAST 32 ACRES OF THE NORTHWEST 1/4 TOGETHER WITH THAT PART OF THE WEST 32.29 ACRES OF THE NORTHEAST 1/4 OF SECTION 21, TOWNSHIP 52 NORTH, RANGE 33 WEST OF THE 5TH PRINCIPAL MERIDIAN, KANSAS CITY, PLATTE COUNTY, MISSOURI, WHICH LIES SOUTHERLY OF MISSOURI STATE HIGHWAY ROUTE NO. 291 AND NORTHERLY OF INTERSTATE HIGHWAY NO. 435, MORE PARTICULARLY DESCRIBED BY TIMOTHY BLAIR WISWELL, PLS 200900067, OF GEORGE BUTLER ASSOCIATES, INC., CLS 000059, ON MARCH 14, 2024, AS FOLLOWS:

***COMMENCING AT THE NORTHWEST CORNER OF SAID NORTHWEST 1/4; THENCE N89° 33' 48" E ON THE NORTH LINE OF SAID NORTHWEST 1/4, 2644.88 FEET TO AN AXLE AT THE APPARENT NORTHEAST CORNER OF SAID NORTHWEST 1/4; THENCE S0° 14' 35" W ON THE EAST LINE OF SAID NORTHWEST 1/4, 25.00 FEET TO THE **POINT OF BEGINNING ON THE SOUTH RIGHT-OF-WAY LINE OF COOKINGHAM DRIVE; THENCE N89° 24' 05" E ON SAID SOUTH RIGHT-OF-WAY LINE, 209.70 FEET TO THE SOUTH RIGHT-OF-WAY LINE OF MISSOURI HIGHWAY ROUTE 291; THENCE S0° 47' 11" E ON SAID SOUTH RIGHT-OF-WAY LINE, 9.53 FEET TO A POINT 30.00 FEET LEFT OF CENTERLINE HIGHWAY STATION 665+00; THENCE S77° 57' 48" E ON SAID SOUTH RIGHT-OF-WAY LINE, 135.17 FEET TO A POINT 80.00 FEET LEFT OF CENTERLINE HIGHWAY STATION 664+10 BACK = 663+68.2 AHEAD; THENCE N89° 12' 49" E ON SAID SOUTH RIGHT-OF-WAY LINE, 185.61 FEET TO THE EAST LINE OF SAID WEST 32.29 ACRES; THENCE S0° 09' 10" W ON SAID EAST LINE, 1233.67 FEET TO THE NORTH RIGHT-OF-WAY LINE OF INTERSTATE HIGHWAY ROUTE 435; THENCE N88° 59' 07" W ON SAID NORTH RIGHT-OF-WAY LINE, 529.74 FEET TO THE EAST LINE OF SAID NORTHWEST 1/4; THENCE CONTINUING N88° 59' 07" W ON SAID NORTH RIGHT-OF-WAY LINE, 529.24 FEET TO THE WEST LINE OF SAID EAST 32 ACRES; THENCE N0° 08' 21" E ON SAID EAST LINE, 1243.85 FEET TO THE SOUTH RIGHT-OF-WAY LINE OF SAID COOKINGHAM DRIVE; BEING 25.00 FEET SOUTH FROM AS MEASURED PERPENDICULAR TO, THE NORTH LINE OF SAID NORTHWEST 1/4; THENCE N89° 33' 48" E ON SAID SOUTH RIGHT-OF-WAY LINE, 531.49 FEET TO THE POINT OF BEGINNING.

AND

ALL THAT PART OF THE NORTHEAST QUARTER OF SECTION 21, TOWNSHIP 52 NORTH, RANGE 33 WEST OF THE 5TH PRINCIPAL MERIDIAN, KANSAS CITY, PLATTE COUNTY, MISSOURI, WHICH LIES SOUTHERLY OF MISSOURI STATE HIGHWAY ROUTE NO. 291 AND NORTHERLY OF INTERSTATE HIGHWAY NO. 435, MORE PARTICULARLY DESCRIBED BY TIMOTHY BLAIR WISWELL, PLS 200900067, OF GEORGE BUTLER ASSOCIATES, INC., CLS 000059, ON MARCH 14, 2024, AS FOLLOWS:

COMMENCING AT THE NORTH CORNER OF SAID SECTION 21; THENCE N89° 24' 10" E ON THE NORTH LINE OF SAID SECTION 21, A DISTANCE OF 527.78 FEET TO A POINT ON THE NORTHERLY EXTENSION OF THE EAST LINE OF SPECIAL WARRANTY DEED INSTRUMENT #2020011315, BOOK 1335, PAGE 367; THENCE S00° 08' 57" W ON SAID EXTENDED LINE, A DISTANCE OF 63.48 FEET TO A POINT 1.72" REBAR, SAID POINT ALSO BEING ON THE SOUTH RIGHT-OF-WAY LINE OF HIGHWAY ROUTE 291; *THE POINT OF BEGINNING; THENCE N89° 13' 23" E, ON SAID SOUTH RIGHT-OF-WAY LINE, A DISTANCE OF 25.52 FEET, TO A POINT BEING 60 FEET SOUTH OF ROUTE NO. 291 CENTERLINE STATION 661+98.40; THENCE S83° 17' 47" E ON SAID SOUTH LINE, A DISTANCE OF 95.57 FEET, TO A POINT BEING 70 FEET SOUTH OF STATION 661+00.00, SAID POINT ALSO BEING THE BEGINNING OF A NON-TANGENT CURVE; THENCE ON SAID CURVE TO THE RIGHT, HAVING AN INITIAL TANGENT OF N87° 49' 27" W, A RADIUS OF 1839.86, THROUGH A CENTRAL ANGLE OF 10° 00' 03", AND AN ARCH LENGTH OF 321.63 FEET, TO A POINT BEING 70 FEET SOUTH OF STATION 657+66.62, AND THE MOST WESTERLY CORNER OF WARRANTY DEED #0903 BOOK 559 PG 708; THENCE S63° 31' 08" E, DEPARTING SAID SOUTH RIGHT-OF-WAY LINE, ON THE SOUTH LINE OF SAID DEED, A DISTANCE OF 879.52 FEET TO THE MOST SOUTHEASTERLY CORNER OF SAID DEED, ALSO BEING 76.88 FEET LEFT/SOUTHWEST OF STATION 648+42.48; THENCE S34° 01' 45" E, ON THE SOUTH RIGHT-OF-WAY LINE OF SAID ROUTE 291, SHOWN ON THE HIGHWAY NO. 435 PLANS, A DISTANCE OF 91.18 FEET, TO A POINT, 100.0 FEET LEFT/SOUTHWEST, OF STATION 647+50; THENCE S68° 28' 48" E ON SAID RIGHT OF WAY LINE, A DISTANCE OF 10.61 FEET, TO A POINT ON THE WEST LINE OF WARRANTY DEED #0903 BOOK 559 PG 708; THENCE S41° 01' 39" W, DEPARTING SAID RIGHT-OF-WAY LINE, ON SAID WEST LINE, A DISTANCE OF 185.49 FEET TO A POINT OF CURVATURE; THENCE ON SAID CURVE TO THE LEFT, AND ON SAID WEST LINE, HAVING A RADIUS OF 1367.39 FEET, THROUGH A CENTRAL ANGLE OF 15° 00' 00" AN ARC LENGTH OF 357.98 FEET, TO A POINT OF TANGENCY; THENCE S26° 01' 39" W ON SAID WEST LINE, A DISTANCE OF 293.70 FEET, TO A POINT ON THE NORTHERLY RIGHT OF WAY LINE OF INTERSTATE HIGHWAY NO. 435, 175.00 FEET NORTH OF STATION 931+88.32; THENCE N88° 58' 21" W ON SAID NORTHERLY RIGHT OF WAY LINE, A DISTANCE OF 212.32 FEET, TO A POINT BEING 175.00 FEET NORTH OF STATION 729+76.00; THENCE S88° 45' 19" W ON SAID NORTHERLY RIGHT OF WAY LINE A DISTANCE OF 630.55 FEET, TO A FOUND 1/2" REBAR, ALSO BEING 150.00 FEET NORTH OF STATION 924+50.00; THENCE N00° 08' 57" E, DEPARTING SAID NORTH RIGHT-OF-WAY LINE, ON THE EAST LINE OF SPECIAL WARRANTY DEED INSTRUMENT #2020011315, BOOK 1335, PAGE 367, A DISTANCE OF 1233.92 FEET, TO THE POINT OF BEGINNING.

CONTAINING 26.82 ACRES - 1,168,062.44 SQ FEET AND BEING SUBJECT TO THAT PART IN ROAD RIGHT-OF-WAY IF ANY.

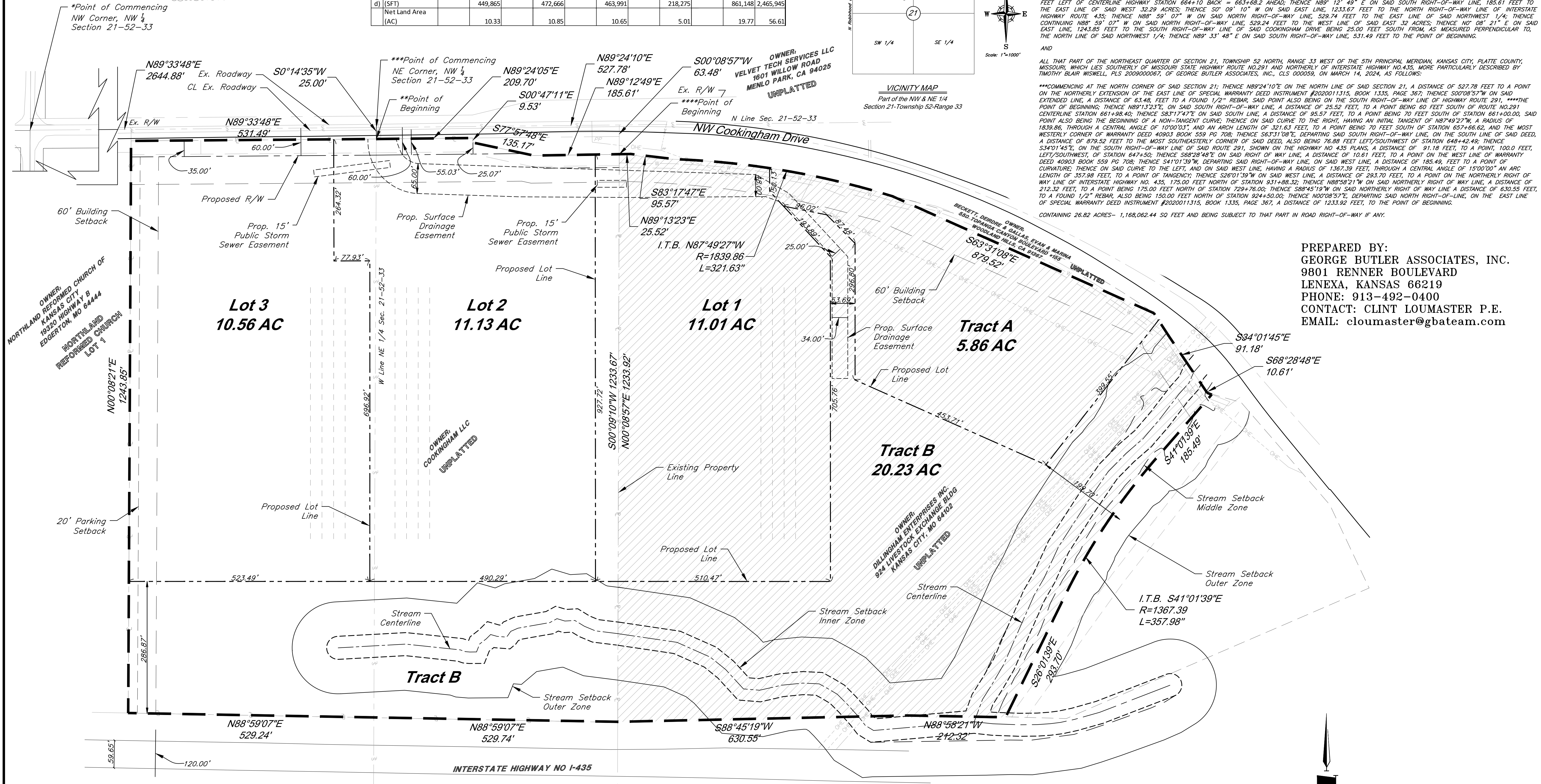

PREPARED BY:
 GEORGE BUTLER ASSOCIATES, INC.
 9801 RENNER BOULEVARD
 LENEXA, KANSAS 66219
 PHONE: 913-492-0400
 CONTACT: CLINT LOUMASTER P.E.
 EMAIL: cloumaster@gbateam.com

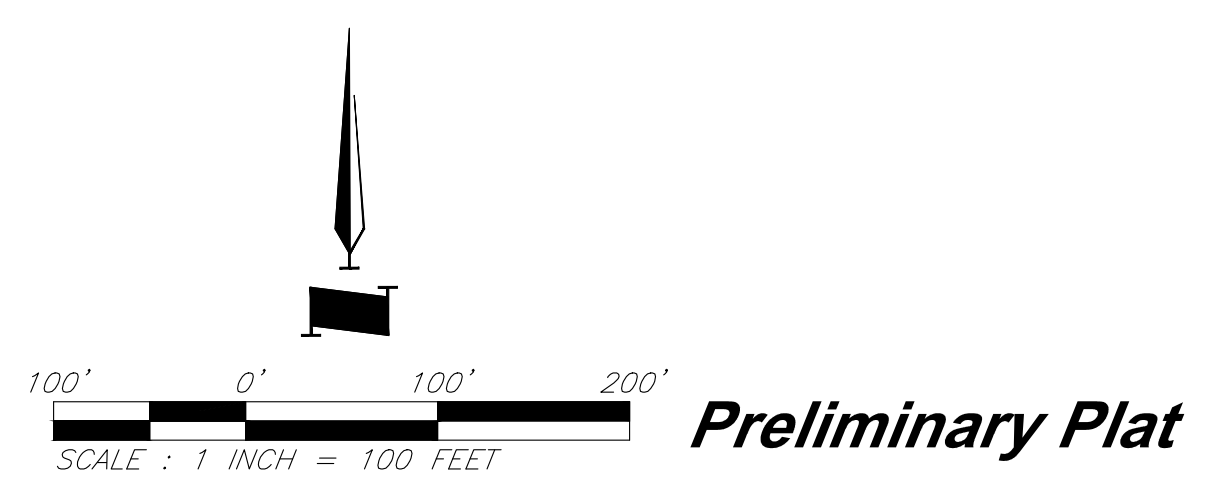

C:\15410.11\Civil\3D\Production Drawings\Rezoning & Preliminary Development Plans\Preliminary Plat\15410.11C3000.dwg Layout: 13 Preliminary Plat Friday, April 19, 2024, 1:50pm Copyright 2024, George Butler Associates, Inc. Professional Engineer, 0001133, Professional Land Surveyor, 000269

STREAM BUFFER PLAN

GBA

9801 Renner Blvd., Ste. 300
Lenexa, KS 66219
913.492.0400
gbateam.com

DATE: 3/15/2024

DESIGN BY: CEL

DRAWN BY: DRW/ELS

PROJECT NO.: 15410.11

SHEET NUMBER

14

Clint Loumaster Professional Engineer License No. PB-2011009651		M2-3 Rezoning - Pre. Development Plan & Pre. Plat COOKINGHAM DEVELOPMENT Kansas City, Missouri	
NO.	DATE	REVISIONS	BY APPROVED
1	4/19/24	City Comments 4/5/2024	ELS



VICINITY MAP
Not to Scale
KCMO Regulated Stream within Property Boundary:
Length = 2426 FT

Stream Buffer Area

Total Stream Buffer Area within project area	9.81 AC
Total Streamside Zone	2.50 AC
Total Middle Zone	0.57 AC
Total Outer Zone	6.74 AC
Mature Vegetation/Steep Slopes in Outer Zone	4.85 AC
Proposed Stream-Side Impact	0.02 AC (0.80%)
Proposed Middle Zone Impact	0.007 AC (1.23%)
Proposed Outer Zone Impact	0.41 AC (6.08%)
Required Stream-Side Zone Mitigation (4:1)	0.08 AC
Required Middle Zone Mitigation (4:1)	0.03 AC
Required Outer Zone Mitigation (1.5:1)	0.62 AC
Total Required Mitigation	0.73 AC
Provided Mitigation	0.84 AC

Legend

- Existing Contour
- Proposed Contour
- Property Line
- Limits of Disturbance
- Regulated Stream Channel
- Stream Buffer Limits of Streamside Zone
- Stream Buffer Limits of Middle Zone
- Stream Buffer Limits of Outer Zone
- Proposed Asphalt Pavement
- Trees Removed
- Trees Preservation
- Stream Buffer Impact
- Proposed Mitigation
- Existing Tree Line
- Streamside Zone
- Middle Zone

Slope Map Legend

- 0% - 15%
- 15% or Greater

General Notes:

- Stream Buffer Signs shall be installed along project boundary at change in bearing and spaced no more than every 100 feet.
- According to the Flood Insurance Rate Maps (FIRMs) for the city of Kansas City, Missouri (29095C0061G, dated January 20th, 2017), the site is situated mainly within Zone X, areas determined to be outside the 0.2% annual chance floodplain. A channel on the site contains Zone AE, special flood hazard areas.
- The project is located in the First Creek Watershed.

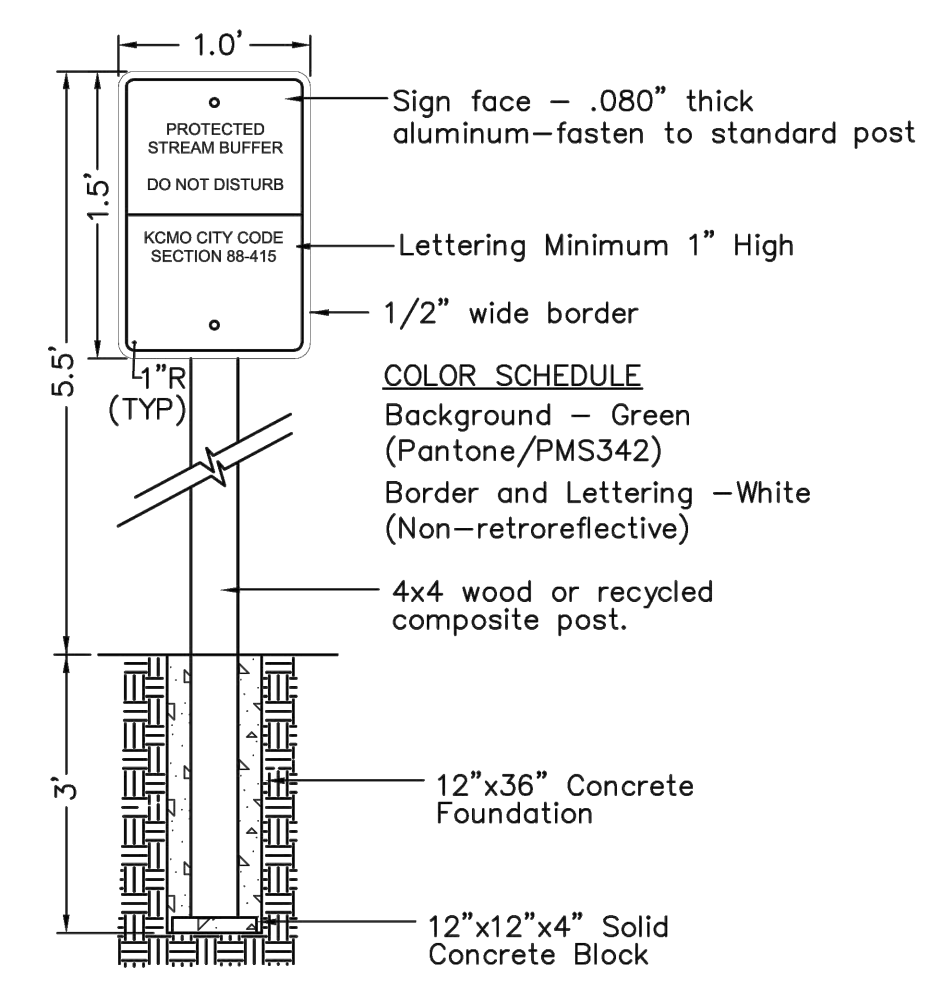
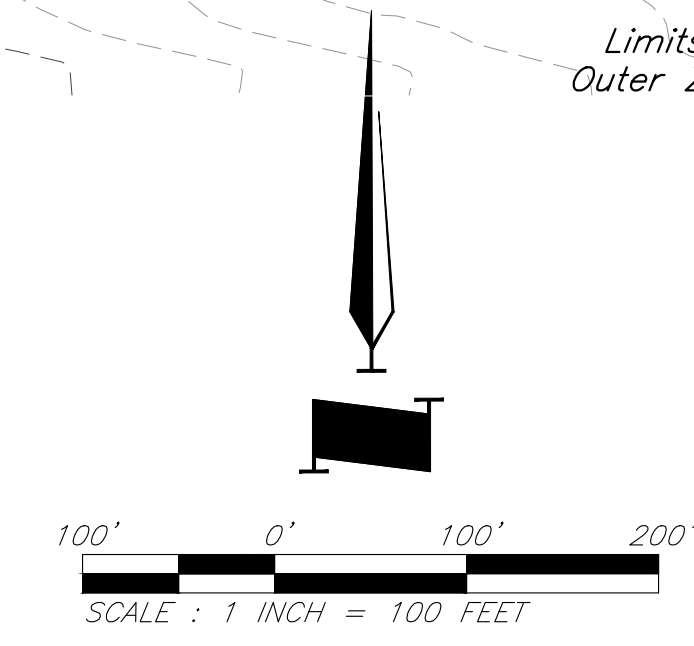
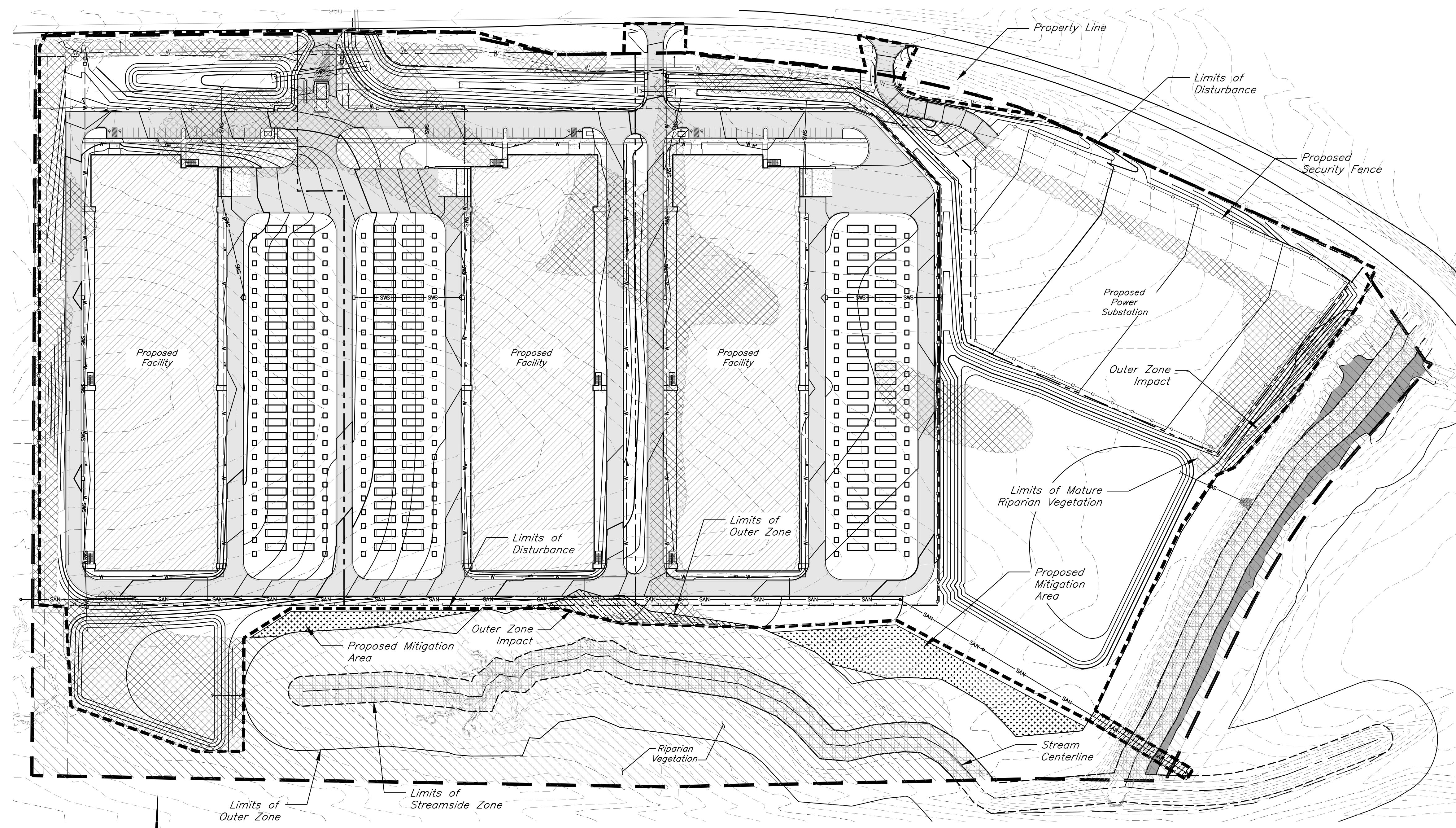

NOTE:
Contractor shall submit a shop drawing for approval prior to construction. Submission shall include a sample representing the noted color schedule.

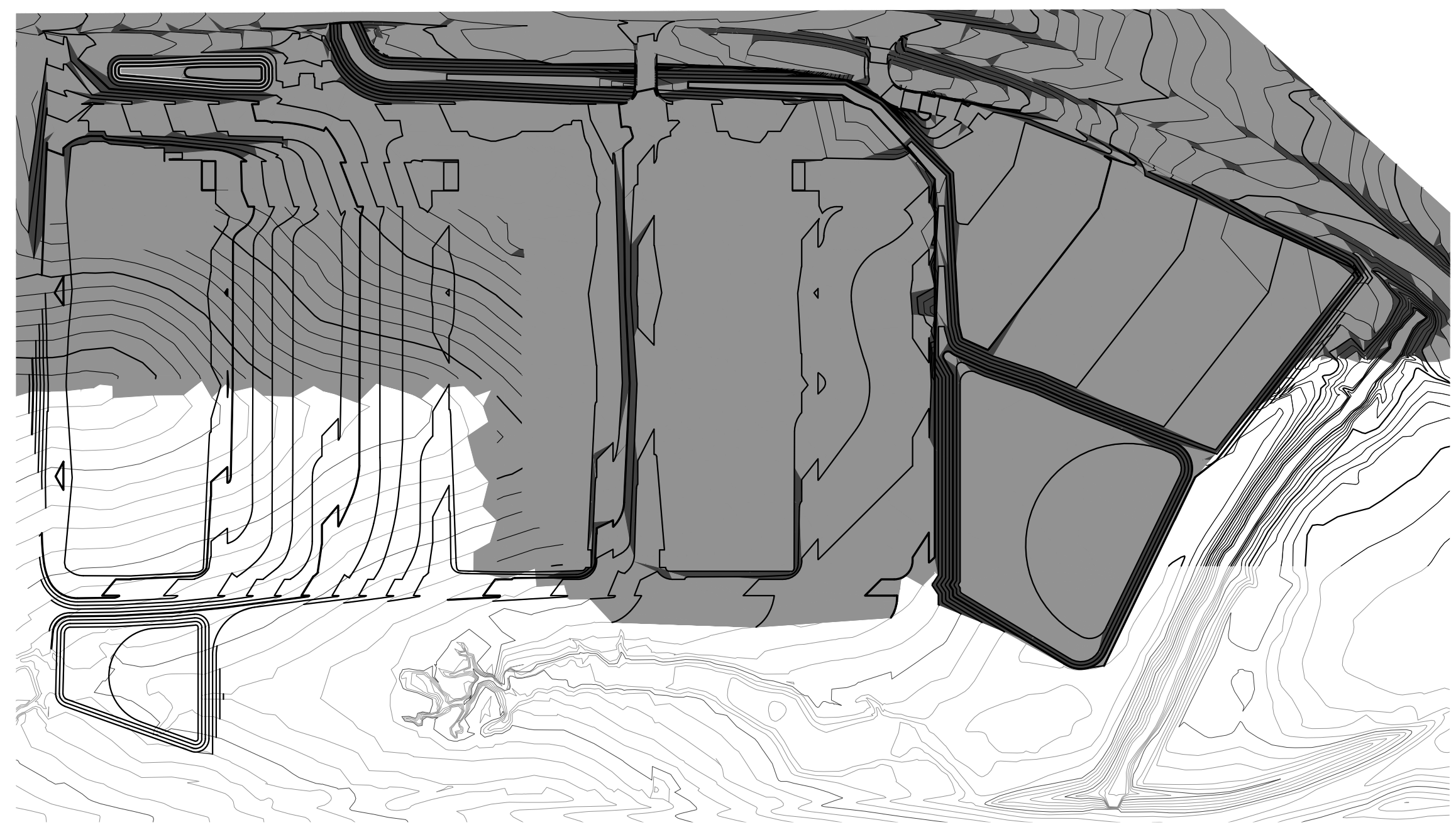

SLOPE MAP

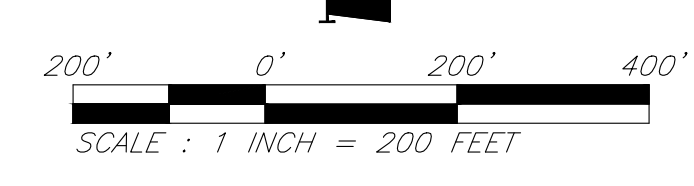

PREPARED FOR:
GBA REALTY LLC
9801 RENNER BOULEVARD
LENEXA, KANSAS 66219
PHONE: 816-876-3893
CONTACT: GRAHAM JONES
EMAIL: gjones@gbabuilders.com

PREPARED BY:
GEORGE BUTLER ASSOCIATES, INC.
9801 RENNER BOULEVARD
LENEXA, KANSAS 66219
PHONE: 913-492-0400
CONTACT: CLINT LOUMASTER P.E.
EMAIL: cloumaster@gbateam.com

C:\15410.11\Civil\3D\Production Drawings\Rezoning & Preliminary Development Plans\Preliminary Stream Buffer Plan\15410.11C2700.dwg Layout: 14 Stream Buffer Plan - Friday, April 19, 2024, 1:51pm - Copyright 2024 by GBA Builders, Inc. Professional Land Surveyor 000269

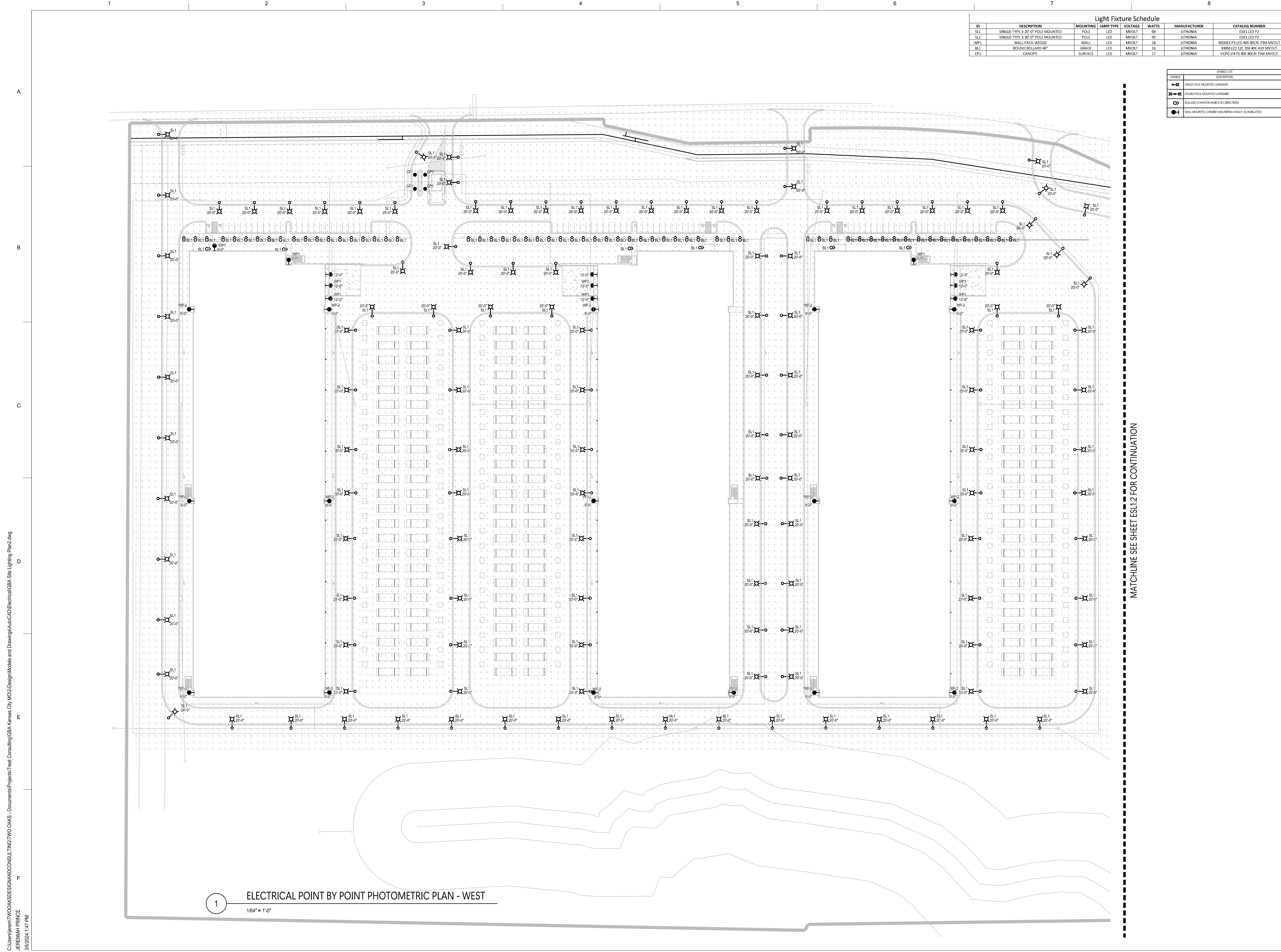

ID	DESCRIPTION	MOUNTING	LAMP TYPE	VOLTAGE	WATTS	MANUFACTURER	CATALOG NUMBER
SL1	SINGLE-TYPE 3-20'-0" POLE MOUNTED	POLE	LED	MVOLT	98	LITHONIA	ESX1 LED P2
SL2	SINGLE-TYPE 3-30'-0" POLE MOUNTED	POLE	LED	MVOLT	99	LITHONIA	ESX1 LED P2
WP1	WALL PACK-WEDGE	WALL	LED	MVOLT	18	LITHONIA	WEDGE P3 LED 40K 80CRI TSM MVOLT
BL1	ROUND BOLLARD 40"	GRADE	LED	MVOLT	16	LITHONIA	KBR8 LED 12V 350 40W ASY MVOLT
CP1	CANOPY	SURFACE	LED	MVOLT	17	LITHONIA	VCP1 V4 P3 40K 80CRI TSM MVOLT

SYMBOL	DESCRIPTION
SL1	SINGLE POLE MOUNTED LUMINAIRE
SL2	DOUBLE POLE MOUNTED LUMINAIRE
WP1	WALL MOUNTED LUMINAIRE
WP2	WALL MOUNTED LUMINAIRE
BL1	BOLLARD (CHEVRON INDICATES DIRECTION)
CP1	WALL MOUNTED LUMINAIRE MOUNTING HEIGHT AS INDICATED

C:\Users\jmt\OneDrive\Documents\TWO OAKS DESIGN\CONSULTING\TWO OAKS - Documents\Projects\Treat Consulting\GBA Kansas City\MO\Design\Models and Drawings\AutoCAD\Electrical\GBA Site Lighting Plan2.dwg
 JEREMIAH PRINCE
 3/6/2024 1:47 PM

1
 ELECTRICAL POINT BY POINT PHOTOMETRIC PLAN - WEST
 1/64" = 1'-0"

MATCHLINE SEE SHEET ESL1.2 FOR CONTINUATION

GBA Realty
 9801 Renner Blvd.
 Lenexa, Kansas 66219

TWO OAKS DESIGN & CONSULTING
 4826 ACADEMY DRIVE
 MADISON, WI 53716
 JOB #:

COOKINGHAM
 DEVELOPMENT
 KANSAS CITY, MISSOURI

CHECKED BY: JP
 ISSUE DATE: 03/12/24

NO.	DATE	DESCRIPTION

SHEET TITLE:
 ELECTRICAL
 POINT BY POINT
 PHOTOMETRIC SITE PLAN
 WEST

ESL1.1
 SHEET NO.

**COOKINGHAM
DEVELOPMENT
KANSAS CITY, MISSOURI**

CHECKED BY JP
ISSUE DATE 03/12/24

REVISIONS

NO.	DATE	DESCRIPTION

SHEET TITLE:
ELECTRICAL
POINT BY POINT
PHOTOMETRIC SITE PLAN
EAST

ESL1.2

SHEET NO.

MATCHLINE SEE SHEET ESL1.1 FOR CONTINUATION

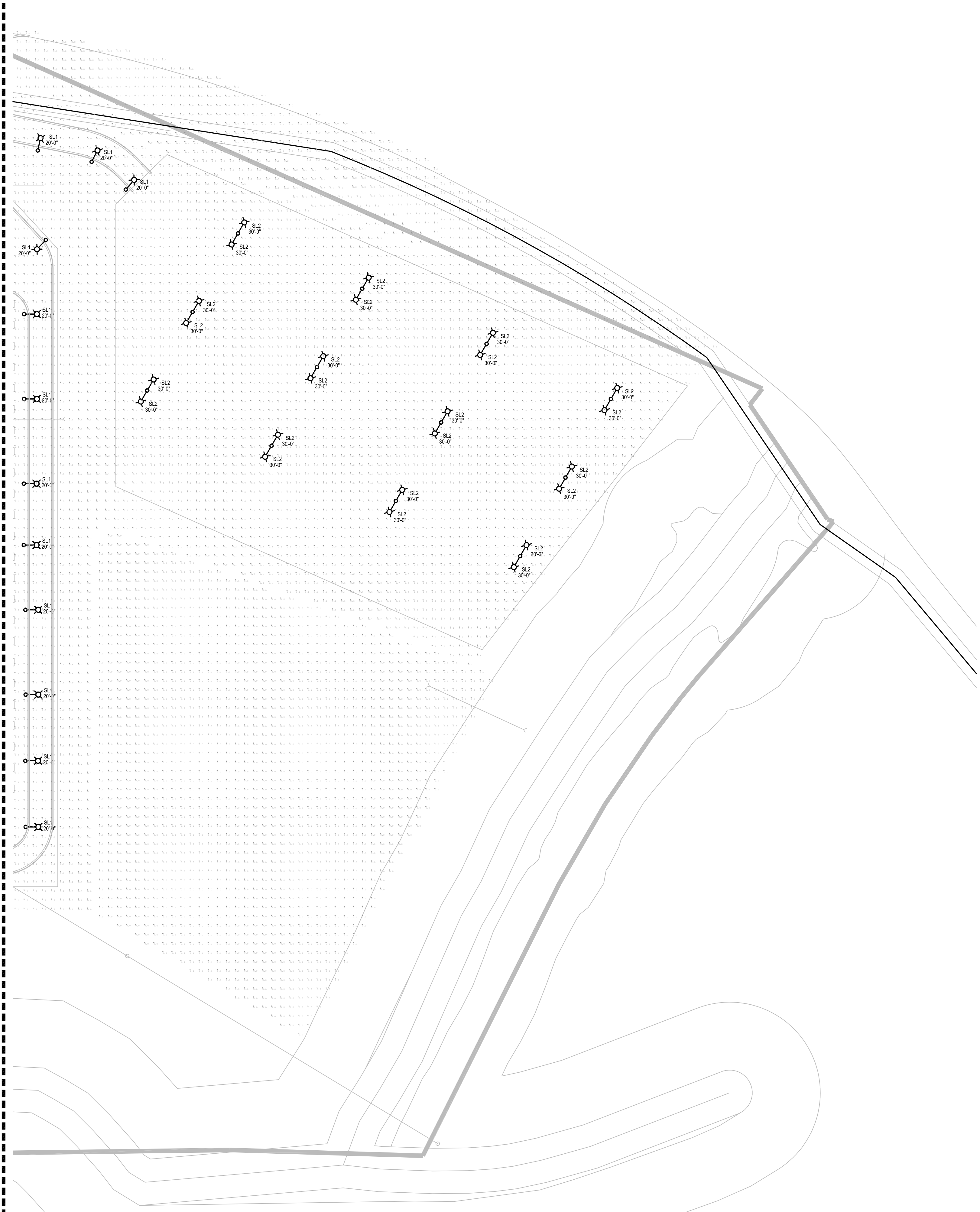

1 ELECTRICAL POINT BY POINT PHOTOMETRIC PLAN - EAST
1/64" = 1'-0"

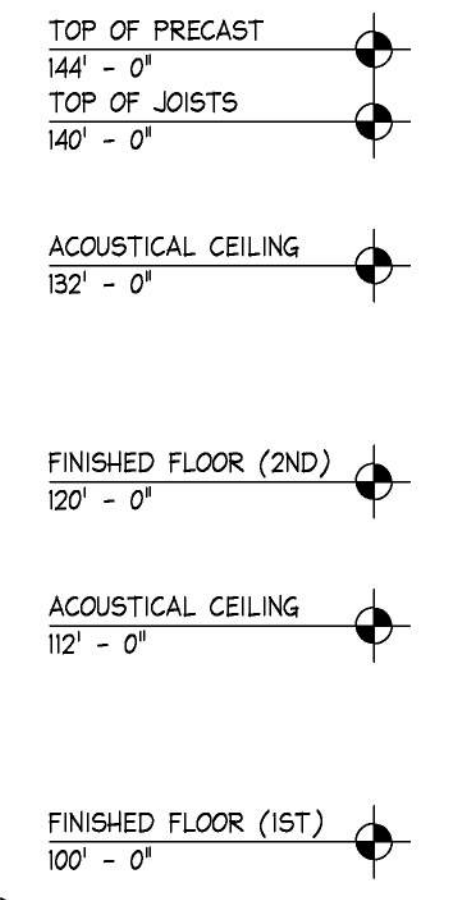
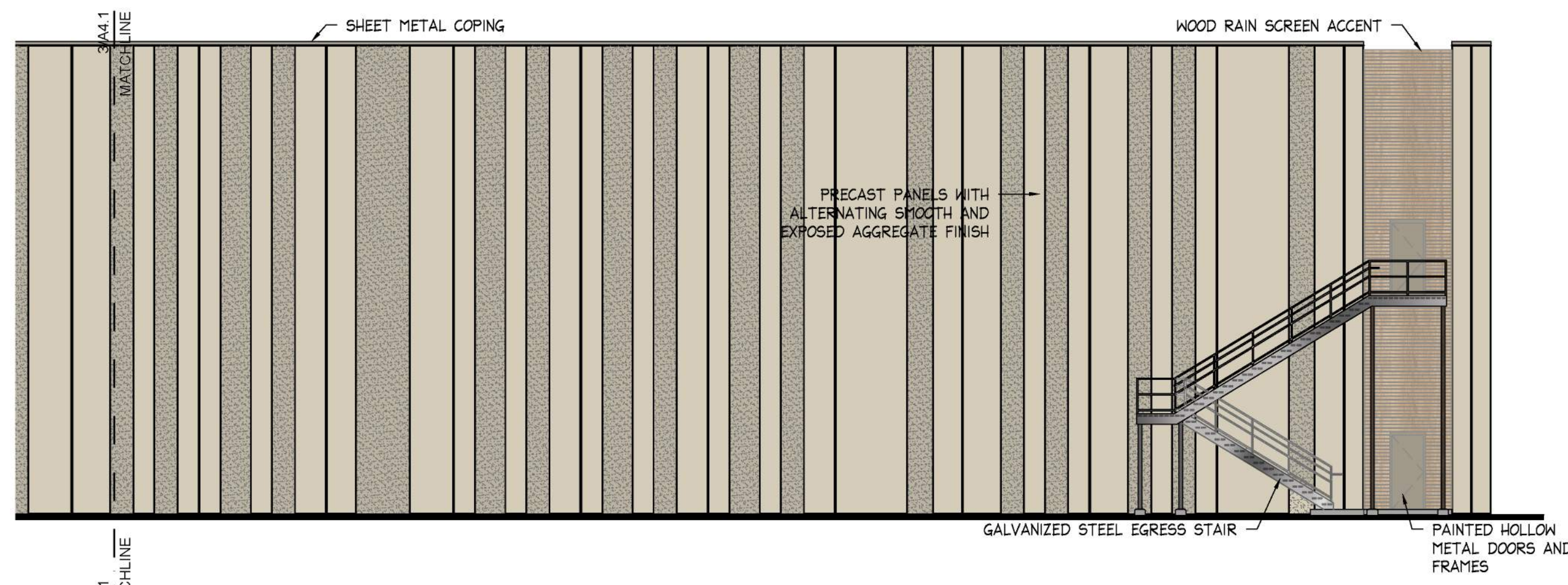

DATE: 3/15/2024
 DESIGN BY: SSC
 DRAWN BY: SSC
 PROJECT NO.: 23-034
 SHEET NUMBER: **A4.1**

Bell / Knott & Associates
 CORPORATE ARCHITECTS, P.C.
 12730 State Line Road Suite 100 Leawood, KS 66209
 Voice: 913.378.1600 Fax: 913.378.1601 www.bellknott.com

Kerry L. Knott
 Registered Architect
 License No. A-4990

M2-3 Rezoning - Pre. Development Plan & Pre. Plat
COOKINGHAM DEVELOPMENT
 Kansas City, Missouri

NO.	DATE	REVISIONS	BY	APPROVED

General Note: All buildings and other structures shall be constructed of high quality materials including masonry, concrete, glass and metal (when used in an incidental role). Specific materials which will be excluded included exposed (i) galvanized metal facades, (ii) nondecorative cinder or concrete block, and (iii) double T concrete panels. Accessory buildings, Compactors, appurtenant structures to, or extrusions from, any building or structure shall be of similar or compatible materials, design and construction.

4 Partial Building Elevation
 West Facing
 3/32" = 1'-0"

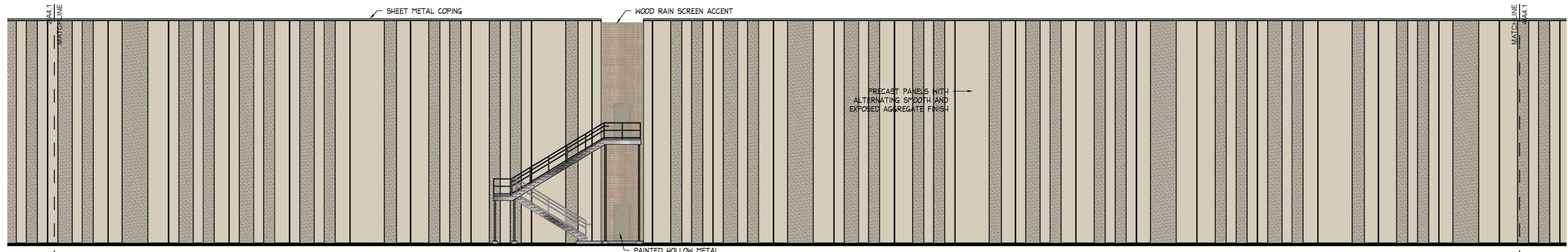

3 Partial Building Elevation
 West Facing
 3/32" = 1'-0"



2 Partial Building Elevation
 West Facing
 3/32" = 1'-0"

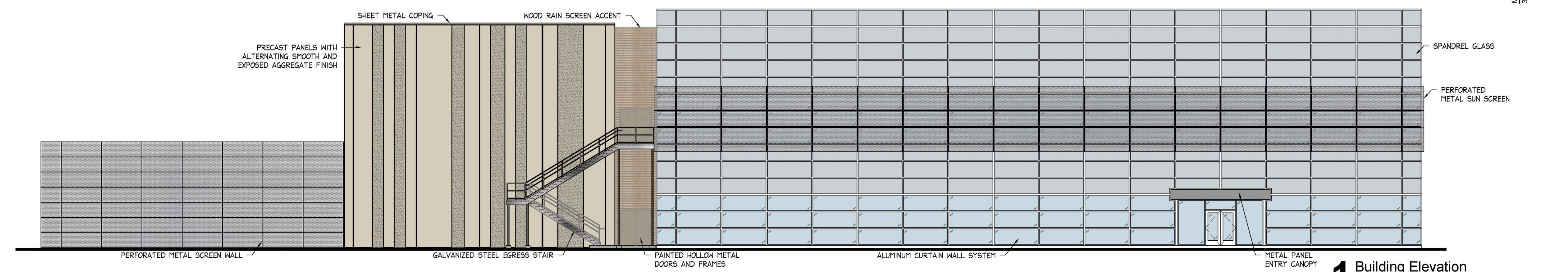

1 Building Elevation
 North Facing
 3/32" = 1'-0"

	DATE: 3/15/2024
	DESIGN BY: SSC
	DRAWN BY: SSC
	PROJECT NO.: 23-034

Bell / Knott & Associates
CORPORATE ARCHITECTS, P.C.
12730 State Line Road Suite 100 Leawood, KS 66209
Voice: 913.378.1600 Fax: 913.378.1601 www.bellknott.com

SHEET NUMBER
A4.2

Kerry L. Knott
Registered Architect
License No. A-4990

M2-3 Rezoning - Pre. Development Plan & Pre. Plat
COOKINGHAM DEVELOPMENT
Kansas City, Missouri

NO.	DATE	REVISIONS	BY	APPROVED

General Note: All buildings and other structures shall be constructed of high quality materials including masonry, concrete, glass and metal (when used in an incidental role). Specific materials which will be excluded included exposed (i) galvanized metal facades, (ii) nondecorative cinder or concrete block, and (iii) double T concrete panels. Accessory buildings, Compactors, appurtenant structures to, or extrusions from, any building or structure shall be of similar or compatible materials, design and construction.

- TOP OF PRECAST 144' - 0"
- TOP OF JOISTS 140' - 0"
- ACOUSTICAL CEILING 132' - 0"
- FINISHED FLOOR (2ND) 120' - 0"
- ACOUSTICAL CEILING 112' - 0"
- FINISHED FLOOR (1ST) 100' - 0"

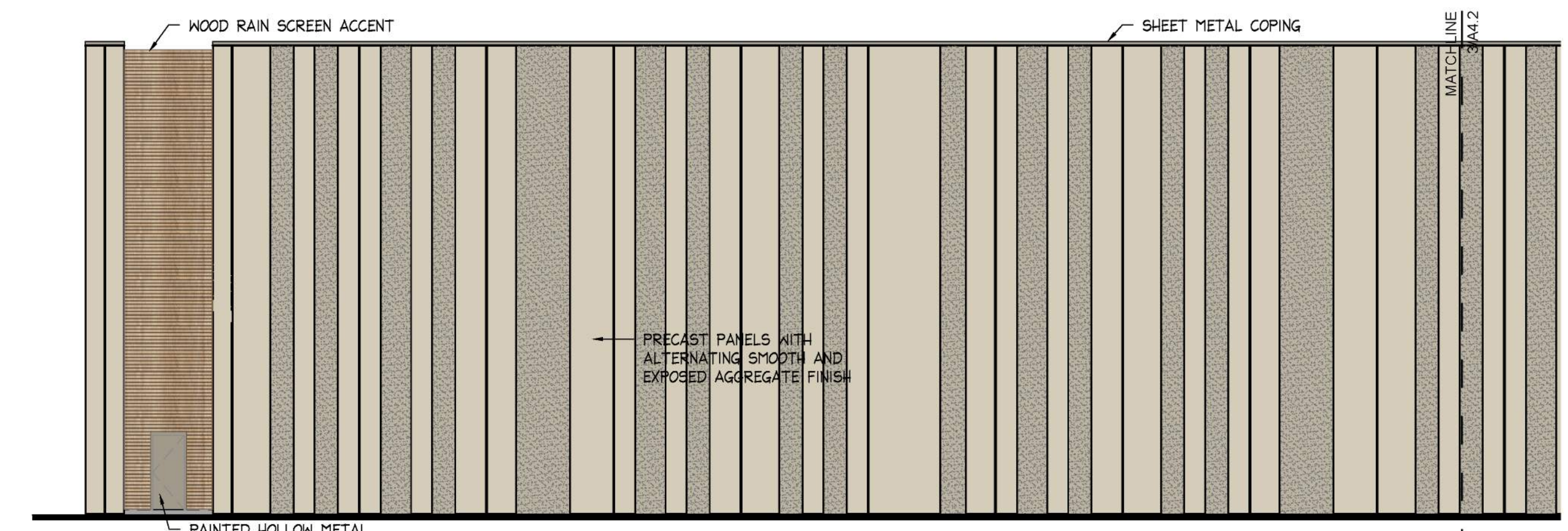

4 Partial Building Elevation
East Facing
3/32" = 1'-0"

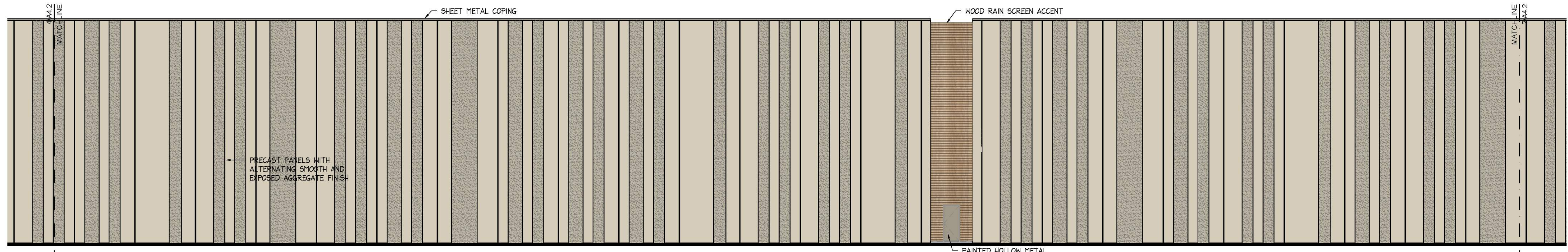

3 Partial Building Elevation
East Facing
3/32" = 1'-0"

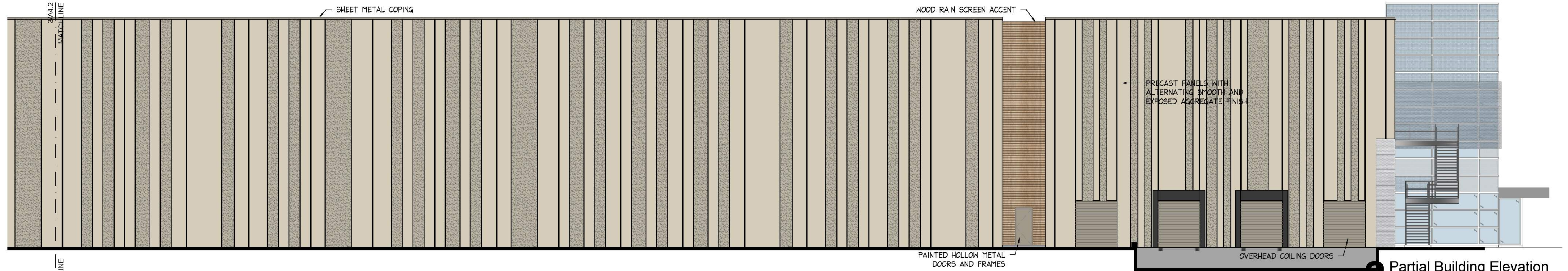

2 Partial Building Elevation
East Facing
3/32" = 1'-0"

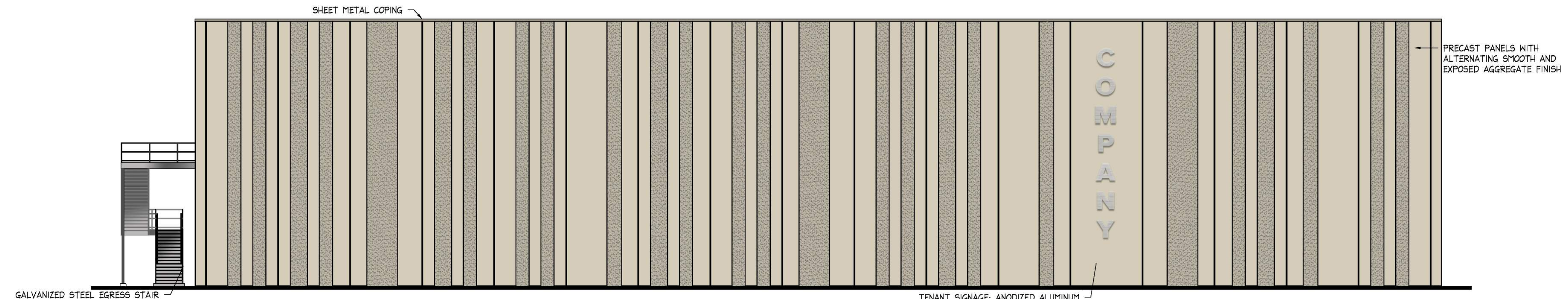

1 Building Elevation
South Facing
3/32" = 1'-0"

GALVANIZED STEEL EGRESS STAIR

TENANT SIGNAGE: ANODIZED ALUMINUM INTERNALLY ILLUMINATED LETTERS ON PRECAST BACKGROUND.

	Bell / Knott & Associates CORPORATE ARCHITECTS, P.C. 12730 State Line Road Suite 100 Leawood, KS 66209 Voice: 913.378.1600 Fax: 913.378.1601 www.bellknott.com	DATE: 3/15/2024
		DESIGN BY: SSC
		DRAWN BY: SSC
PROJECT NO.: 23-034		SHEET NUMBER
		A4.3
Kerry L. Knott Registered Architect License No. A-4990		M2-3 Rezoning - Pre. Development Plan & Pre. Plat COOKINGHAM DEVELOPMENT Kansas City, Missouri
NO.	DATE	REVISIONS

SHEET METAL COPING



PRECAST CONCRETE PANELS WITH SMOOTH & EXPOSED AGGREGATE FINISH

WOOD RAIN SCREEN



ALUMINUM CURTAIN WALL SYSTEM

PAINTED HOLLOW METAL DOORS & FRAMES

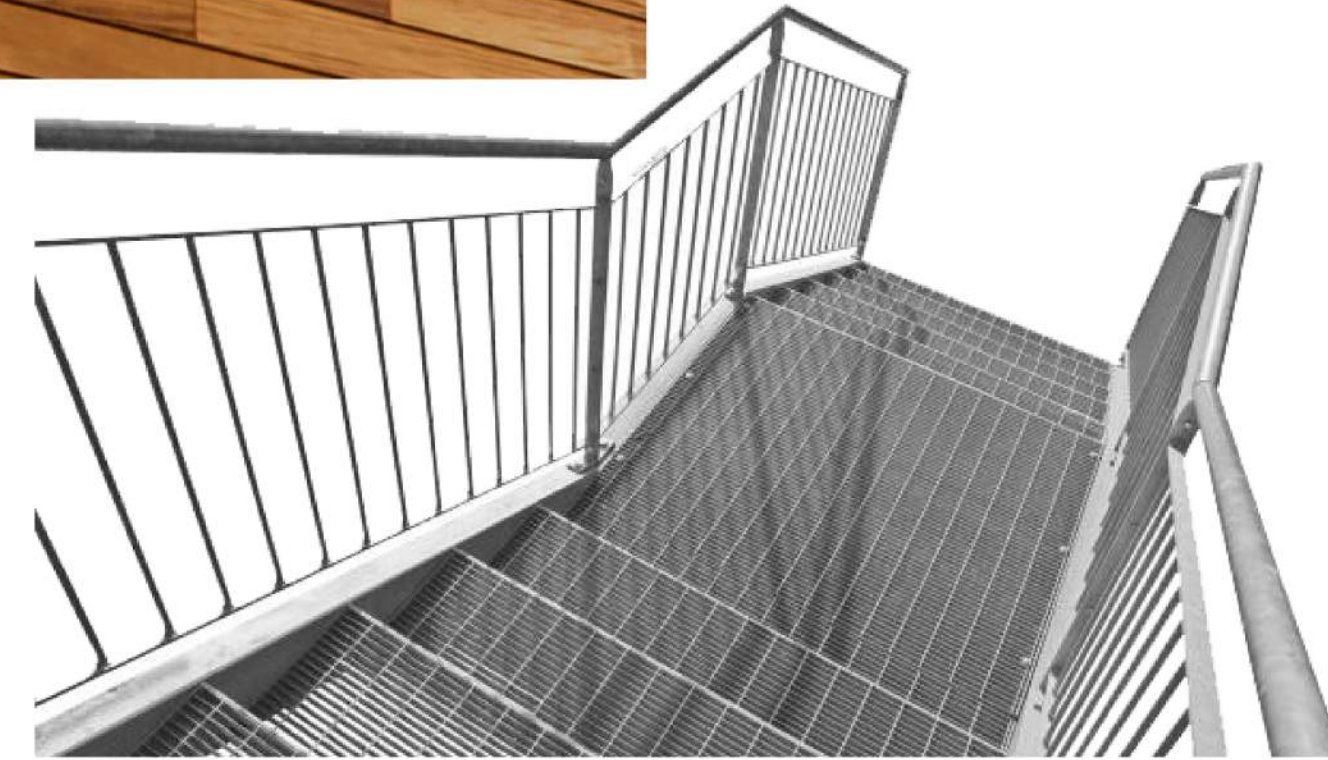
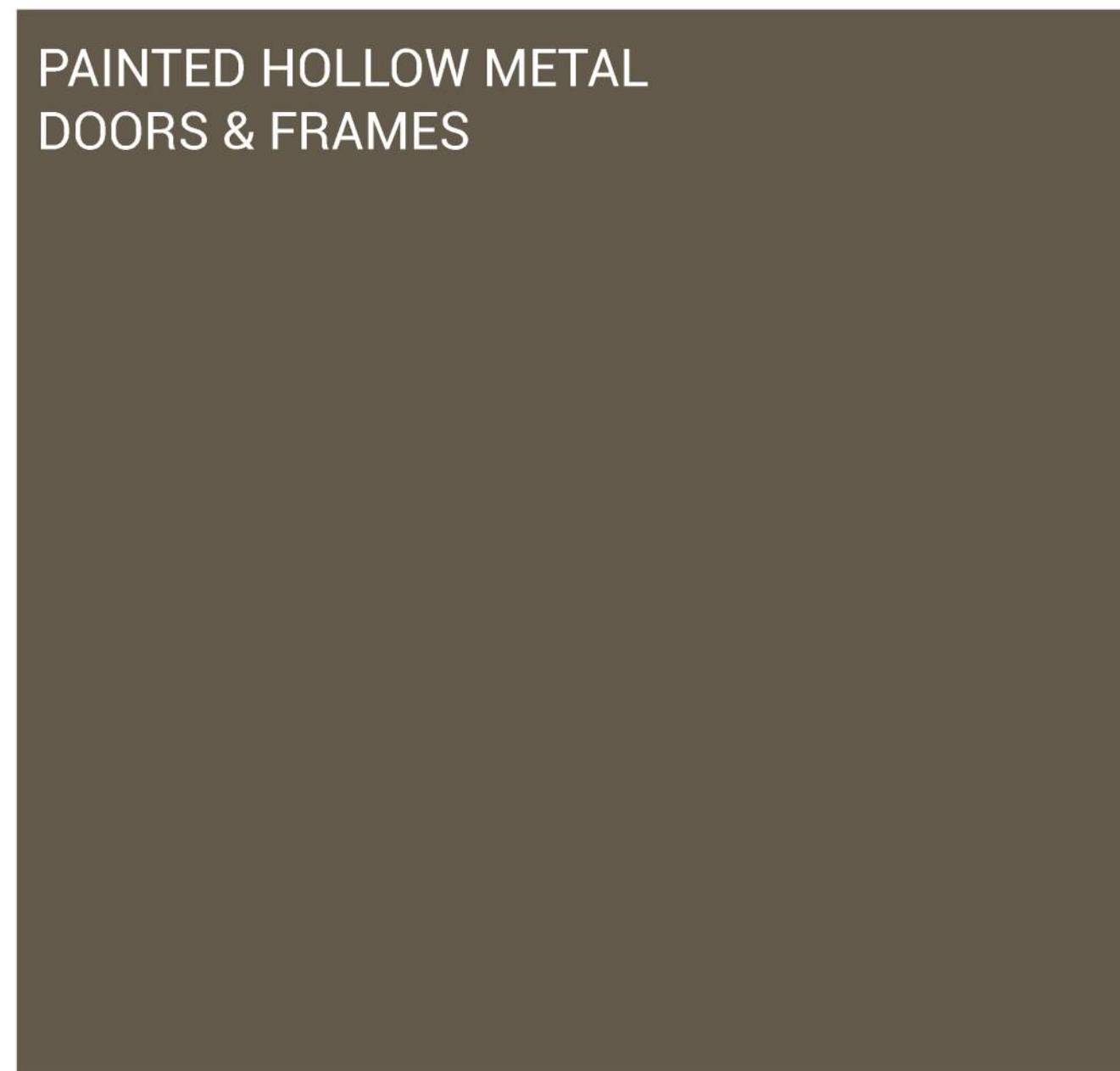

GALVANIZED STEEL STAIRS



DECORATIVE SECURITY FENCING

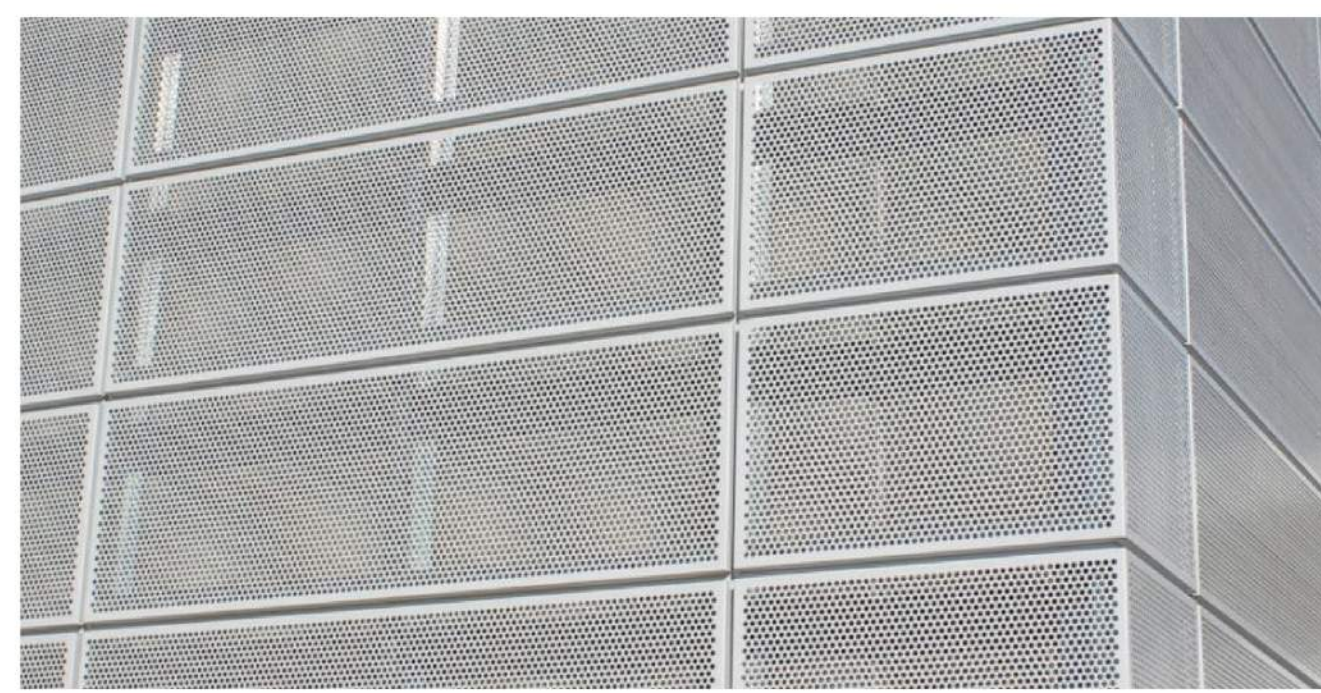

PERFORATED METAL SCREEN WALL / SUN SCREEN

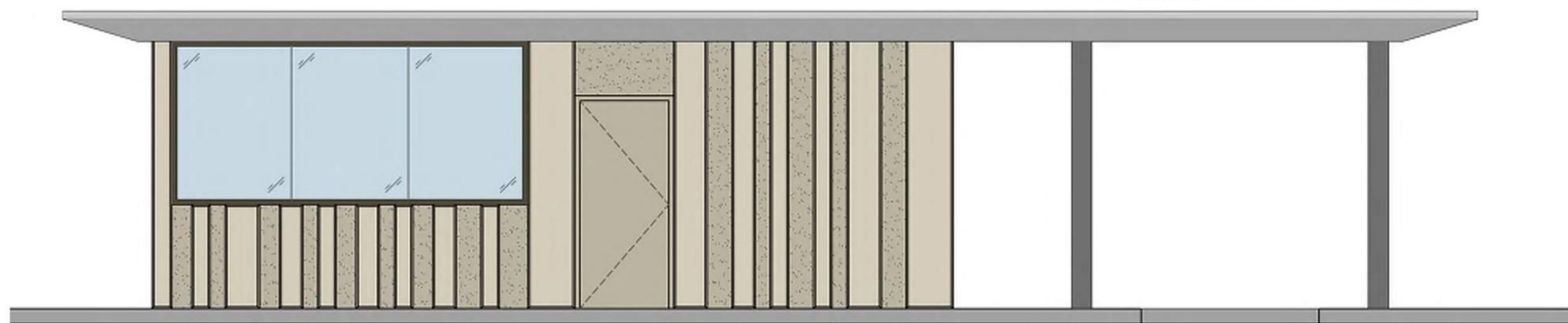

2 Guard House Side Elevation
1/4" = 1'-0"

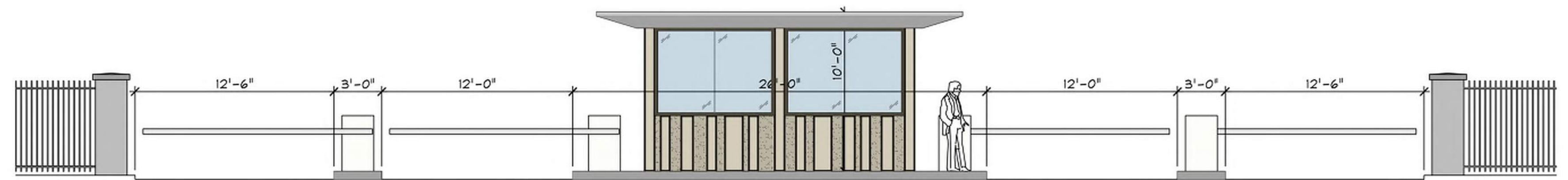

1 Guard House Front Elevation
3/16" = 1'-0"



CITY PLANNING & DEVELOPMENT

Public Meeting Summary Form

Project Case #

Meeting Date:

Meeting Location:

Meeting Time (include start and end time):

Additional Comments (optional):

Meeting Sign-In Sheet

Project Name and Address

Name	Address	Phone	Email
No Attendees			