

# KCMO Safe Streets for All - Streets Design Guide

---

November 2025



# Table of Contents

<b>Introduction .....</b>	<b>3</b>
<b>Safe Streets Principles .....</b>	<b>5</b>
<b>Street Typologies .....</b>	<b>20</b>
Downtown Core .....	23
Urban Mixed-Use .....	28
Suburban Commercial .....	33
Thoroughfare .....	38
Connector .....	43
Neighborhood .....	47
Industrial / Business Park .....	53
Boulevards .....	58
Parkways .....	62
<b>Design Guidance .....</b>	<b>68</b>
<b>Implementation .....</b>	<b>90</b>

# Introduction

Kansas City's Streets Design Guide (SDG) was developed through a Safe Streets for All (SS4A) grant awarded to Kansas City by FHWA to conduct supplemental planning efforts to help implement the City's Vision Zero Action Plan. The purpose of the SDG is to help focus Kansas City's (the City's) street design, construction, maintenance, and rehabilitation projects on safety, multimodal access, context sensitivity, and speed management. This Streets Design Guide is an effort to update city design standards in accordance with the Vision Zero and Complete Streets policies and to bring them into a single document for use by City staff and design consultants.

In 2020, the City Council passed the Vision Zero resolution to eliminate traffic fatalities and serious injuries on Kansas City streets by 2030, while increasing safe, healthy, equitable mobility for everyone. This document will support and expand the work already underway across the City's transportation network to reduce fatalities and injuries by standardizing practices that reduce speeds; reduce conflict points; provide safer facilities for pedestrians, cyclists and other vulnerable road users; and provide clearer guidance to drivers and other roadway users.

This document updates and replaces the City's previous 5200 Street Design Criteria. It also introduces new roadway typologies, replacing those previously shown in the Major Street Plan. This document also references design standards for Boulevards and Parkways, trails, personal mobility lanes (also known as bike facilities), and transit corridors from other City documents.

## Organization of the Streets Design Guide

The Streets Design Guide is organized into four sections:

1. **Safe Streets Principles** provides the foundational framework for reducing the likelihood and severity of crashes on the street network and the justification for the City's design standards.
2. **Street Typologies** illustrates the street categories for which design guidance and standards are to be applied.
3. **Design Guidance** presents standards and guidance for the design of common corridor and intersection elements in accordance with safe streets principles.
4. **Implementation** guides the reader through the process of prioritizing and executing different project types in accordance with safe streets principles and the City's design standards and policies.

## How to Use the Streets Design Guide

The Streets Design Guide serves several audiences and purposes, all centered around promoting a culture of safety within every project on the transportation network.

**For design consultants:** The Design Guidance section of the SDG serves as a one-stop-shop for the City's street design standards, policies, and guidance. The Street Typologies section provides guidance for additional design choices based on roadway typology.

**For City project managers:** The Design Guidance section provides the standards that designers and consultants are required to follow and should be verified by project managers. The Street Typologies section provides guidance for design choices for which designers may seek guidance. The Safe Streets Principle section documents the City's priorities and rationale for the design guidance presented in later chapters.

**For City Public Works staff:** The implementation guidance in the Implementation section points to safety improvements that can be incorporated during executes public works projects that require street maintenance activities.

**For City Parks and Recreation staff:** Design standards for Boulevards and Parkways are set by the Parks and Recreation department and have historically been centered around preserving a specific look and feel for those corridors. The Street Typologies section of the SDG includes Boulevards and Parkways as street typologies, acknowledging their historical context while adding best practices for safer operations and multi-modal access.

**For maintenance crews:** The design standards presented in the Design Guidance section illustrate changes to the way common corridor and intersection elements are designed. Maintenance activities often provide an opportunity to update some street elements in alignment with new standards. Before rebuilding a facility to its previous design, maintenance crews should verify their projects meet updated city policies and practices.

**For construction contractors:** As projects are let, design elements may be different than what contractors are used to building. The Design Guidance section can be referenced to verify unexpected design elements are correct and the Street Typologies section can be referenced to learn more about justification for the changes.

**For elected officials:** The Street Typologies section, and the associated City Street Typologies map, can be shared with constituents to show them the intended functionality of their streets and the design standards the City will be using to update their streets over time. The entire document can also be used to highlight the City's commitment to transportation safety and the standards and policy changes being implemented to reduce fatal and serious injury crashes.

**For safety advocates:** The SDG carries forward the recommendations from the City's Vision Zero Action Plan, which was developed by a multi-disciplinary group and informed by thorough community engagement. It shows a shift in focus from efficiency for automobile trips to safety and accessibility for all users. Safety advocates can use the document to take pride in the work completed to date and to push for continued safety improvement on our streets.

# Safe Streets Principles

The principles discussed here are the foundation of design standards and guidance presented later in this document. They draw on industry knowledge—including from the National Association of City Transportation Officials (NACTO), the American Association of State Highway and Transportation Officials (AASHTO), and the National Cooperative Highway Research Program (NCHRP)—as well as key resources developed by the City, including the 2022 Vision Zero Action Plan and the Complete Streets Ordinance (Ordinance No. 170949).

This Guide continues well-established practices and procedures for street design but increases focus on access and safety for all users. Acknowledging that too many citizens are being killed and injured on our streets, this Street Design Guide employs strategies for speed management, increases the priority of pedestrian and personal mobility facilities, and makes it easier for designers to include safety features in their projects. The guidance presented is based on decades of traffic safety research and experience.

Streets are important public spaces that can create a sense of place, provide mobility, and support economic vitality. This Guide acknowledges that street design involves delicate management of competing needs and limited resources. No set of design standards can be sufficiently comprehensive as to address every circumstance. In cases that are not covered explicitly or where engineering judgement determines a standard is not appropriate or applicable, the principles discussed in this section can be used as a foundation for decision-making during the design process.

Many effective safety techniques can be applied quickly and easily to any project, especially when using a “quick build” or incremental design approach. Some of the most common scenarios include when:

- citizens bring specific safety concerns to the City’s attention;
- safety analysis from the City or its consultant identifies an acute safety concern;
- a new street is constructed;
- an existing street is reconstructed;
- an ADA project is planned;
- a maintenance or pavement project is scheduled;
- a utility project is planned within the street right-of-way; or
- a planning or engineering study is being conducted.

Application concepts are discussed further in the Implementation chapters of this document. Incorporating safety into every project shows a commitment to a culture of safety and maximizes the benefit of safety investments.

## Street Users

All street users deserve streets that are safe and convenient, regardless of which mode they choose. Streets have historically been designed to prioritize the movement of traffic, focusing first and foremost on motor vehicles. Today, designers can better quantify crash risk and are more likely to consider safety in their design choices. This benefits people using the transportation system, whether they are walking, rolling, or in a vehicle.

A safety focus means fatal and serious injury crashes are a higher priority than fender-benders. And, because pedestrians and cyclists are more vulnerable to serious injury when involved in a crash, designers must prioritize the reduction of crash risk for those groups. In Kansas City, pedestrians and cyclists make up only 2% of crashes, but these vulnerable users are involved in 22% of crashes resulting in serious injury or death.

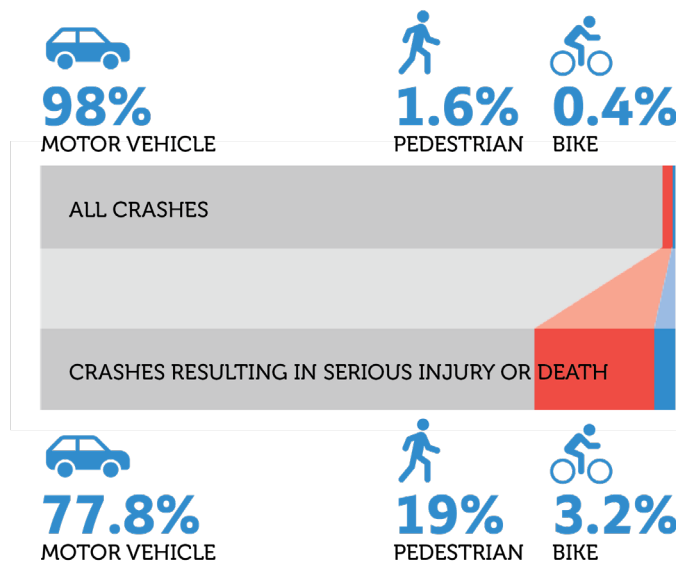

While personal vehicles are the most common mode on city streets, they generally create more risk for vulnerable users than they experience. Operational considerations for motor vehicles are important but should be considered after the safety needs of all other users have been considered and addressed to the extent possible.

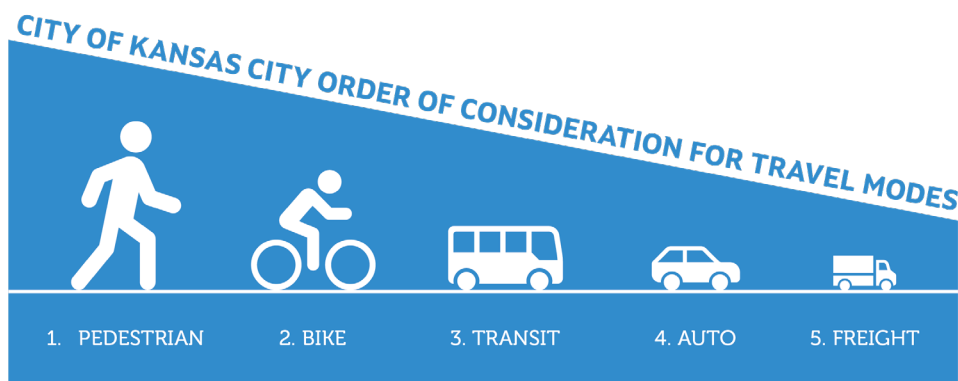

## Pedestrians

Pedestrians are the most vulnerable street users and can include people with unique needs: children, the elderly, or users with limited mobility or vision. Everyone is a pedestrian at times: when they traverse a parking lot, go from their home to a transit stop, or cross the street in a shopping district. All streets should provide dedicated space for pedestrians. Locations with frequent pedestrian traffic, or near residential areas, schools, churches, or shopping/dining districts should emphasize lower vehicle speeds, connected pedestrian sidewalks or paths, high-visibility crossings, lighting, and other amenities to increase comfort, such as benches and shade.

Streets that are primarily designed to accommodate faster-moving vehicles should prioritize separation between vehicle traffic and pedestrians. Where right-of-way is constrained, consideration should be given to reducing pavement width and accommodations for motor vehicles before reducing sidewalk width or buffer space. Additionally, enhanced crossing treatments should be prioritized, at both intersections and mid-block locations, with median refuge areas, actuated pedestrian beacons or signal phases, long sight distances, and advanced signing. Beyond meeting regulatory and design guidance, care should be taken to accommodate pedestrians with mobility or visual limitations where they are expected, including by enhancing the visibility of pedestrians and increasing crossing time.

Shade trees, benches, pedestrian-level lighting, wayfinding, and other features create a sense of place and make users feel more safe and secure. However, maintenance of pedestrian infrastructure and amenities is essential. Sidewalk cracks and trip hazards can make it difficult or impossible to move in a wheelchair or push a stroller, and some features may block the view of pedestrians for motor vehicle drivers. Plantings should be designed so as to prevent roots pushing up on sidewalks, minimize sight obstructions between motor vehicles and pedestrians, and help manage storm water. Where right-of-way is limited, street designers should pay special attention to roadside elements (such as utilities or light poles) that may infringe on pedestrian space.

At intersections, street designers should be cautious of vehicle turn lanes or other features that increase pedestrian crossing distance or allow higher turning speeds. Where street intersections are widely spaced or where trip generators exist at midblock locations, consideration should be given to providing midblock crossing locations with high-visibility pavement marking and signs, and rectangular rapid flashing beacons or pedestrian signals where appropriate.



## Bicycles and Other Micromobility Devices

Bicyclists—as well as those on scooters and other micromobility devices—are the next most vulnerable street users. Like pedestrians, bicyclists need more separation from motor vehicle traffic as vehicle speeds increase. On low-speed, low-volume facilities, bicyclists may be able to ride in the lane with motor vehicle traffic; on high-speed, high-volume streets, bicyclists should be separated entirely from the roadway.

Bicyclists, scooter users and other micromobility users can be especially sensitive to topography. Where traffic moves uphill, bicyclists can be expected to move slower relative to vehicles and should receive greater protection. At intersections, bicyclists should be conspicuous to vehicles and be given traffic signal or physical priority (in bike boxes, for example) to establish their presence.



## Transit

Increasing the share of residents who use transit improves safety, supports urban density, and reduces emissions. For transit to be effective, it must be reliable and frequent. Operation of transit vehicles in mixed traffic increases the risk of delays, especially at peak times. Designated transit lanes and transit priority at intersections can reduce this risk and make transit more attractive.

The transit network is dependent on the pedestrian, personal mobility (bike), and micromobility/microtransit networks because total trip time includes time getting to and from transit stops. Street designers should be thoughtful about modal connections to transit stops and amenities provided to waiting riders.



## Freight

Freight movement is necessary to support economic activity. Freight vehicles are likely to be constrained by the geometry of the roadway and may require additional space for turning movements. These space demands are often similar to those of emergency services and maintenance vehicles and school buses. In areas with pedestrians and/or cyclists, designers should consider elements that balance the needs of both large vehicles and vulnerable users, such as mountable curbs, truck aprons, and recessed stop bars that accommodate wider turns into the opposing lane of traffic.

In denser areas, freight vehicles may also require loading/unloading space along the street. This may be achieved in shared space with other features, such as street parking; however, freight vehicles should never occupy designated pedestrian or bicyclist space. Common freight vehicles will vary by roadway typology and context. Time-of-day restrictions on truck parking and loading/unloading can limit freight conflict with other modes.

## Passenger Vehicles

On much of the City's transportation network, passenger vehicles are the most common user type. However, geometric and traffic control elements designed to reduce vehicle delay can have unintended safety consequences. Street designers should choose street elements that reinforce the intended speed (see "Speed" below). Because of motor vehicle size and speed, the roadway environment should be designed to help drivers see other users, especially through the provision of clear sight lines to pedestrians, bicyclists, and other vehicles at intersections and crossings.

As the motor vehicle fleet continues to incorporate new technologies that increase automation and connectivity, the roadway design should support such technologies. This suggests a focus on design consistency and highly visible pavement markings and traffic control devices.

## Safety Concepts

While “safer roads” is only one element of five in a safe system approach, it is the primary tool for designers to mitigate crash risk. Street design should vary according to adjacent land uses and expected users. This section addresses the various elements that establish a street’s character. The use of design elements within particular contexts is explained in “Typologies”.

### Speed

#### Implications for Safety

Speed management is a critical component of street safety. Traffic speeds are directly related to crash likelihood and severity because they impact:

- The energy transferred in a crash, with energy being proportional to the square of speed
- The distance traveled while a driver perceives and reacts to a hazard or risk
- The size of the driver’s visual field (the area where a driver can observe and interpret visual information)

Moderate increases in speed can substantially increase the risk of a fatal crash. A street user’s likelihood of surviving being struck by a motor vehicle is 90 percent at 23 mph, 50 percent at 42 mph, and only 10 percent at 58 mph. Children and the elderly are much more likely to be killed at all speeds.

Furthermore, high vehicle speeds can make crashes more likely, as faster cars move greater distances before drivers can perceive hazards, brake, and come to a stop. The figure below shows average stopping distances, including driver reaction distance and braking distance, at increasing speeds for passenger vehicles on dry and wet pavement. It shows, for example, that a passenger vehicle traveling at 40 mph requires more than double the stopping distance of the same vehicle traveling at 25 mph. For heavy vehicles, stopping distance is even greater than what is shown in this chart.

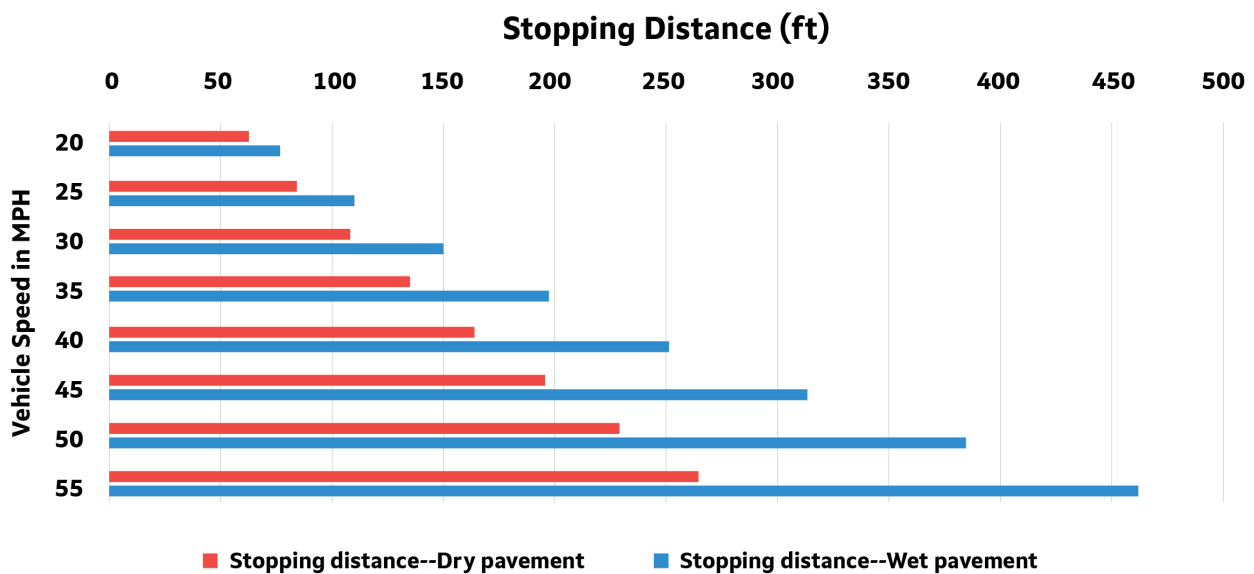

Higher driving speeds also narrow a driver's field of vision, making it more difficult to see an approaching animal, pedestrian, cyclist, or vehicle approaching from the side, as illustrated below.



Source: Vision Zero Network (<https://visionzeronetwork.org/resources/safety-over-speed/>)

### **Designing to Manage Speeds**

Ideally, streets are “self-enforcing”: their design and surrounding land use convey the appropriate travel speed even in the absence of speed limit signs. Because drivers have a lot of visual information to process (especially in dense, urban areas), and speeds are not posted on every block, they rely on clues—often subconsciously—to help them choose their travel speed. Such clues might include lane width; how congested the street is; proximity of objects such as trees, signs, and utility poles to the street; the presence of pedestrians and cyclists; nearby playgrounds, schools, and other indications that children use the street; the frequency of residential and commercial driveways; the allocation of pavement width to parking, transit lanes, personal mobility lanes, or medians; and, perhaps most importantly, the speed of other drivers on the road.

Self-enforcing roads are most effective when roadway characteristics consistently align with the posted speed limit. A comprehensive speed limit review across the City showed that posted speed limits signs did not strongly correlate with mean and 85th-percentile speeds. Instead, features such as on-street parking were much more correlated with driving speeds that were aligned with posted speed limits. Additionally, since drivers rely on their cumulative driving experience to choose travel speed, reducing speed limits as a safety treatment on only some streets may lead to driver confusion about what driving speed is safe and appropriate in a given context.

Rather than using a design speed that exceeds anticipated driving speed or posted speed limit, street designers should set a target speed (see “Elements of Design”) that aligns with the context of the roadway and its expected users. This target speed should be reflected in geometric features, access control, signal timing, modal accommodations and the posted speed limit, which, in turn, are aligned with adjacent land use, development, and density. The Target Speed on a road may not match the existing posted speed limit. The design speed and posted speed limits should be re-evaluated based on the Streets Design Guide and the assigned Street Typology’s Target Speed each time a roadway project occurs.

However, even the best-designed streets can provide inconsistent clues to drivers. For example, some streets may be congested during certain times of day but clear at others. Pedestrians may be present immediately before and after school but infrequent otherwise. The proximity and

density of the streetside landscape may feel different during the spring and summer when foliage is in full bloom than when leaves are absent and sight distance is increased.

Traffic calming measures can bring consistency to travel speeds by creating conditions that require driver awareness and careful control of the vehicle. The following strategies, which can often be accomplished with lower-cost interim treatments, can reduce speeds on an existing street:

- Road diet (from 4 lanes to 3)
- Reduced lane width and intersection corner radii
- Traffic calming devices (speed humps, raised medians)
- Coordination of traffic signals to support traffic progression at a slower speed and prioritize pedestrians and bicyclists (such as leading pedestrian intervals)
- Roundabouts at intersections
- On-street parking and curb extensions
- Street enhancement features (textured pavement, street trees)
- Elimination of slip lanes, channelized right-turn lanes, and other features that encourage faster speeds at conflict points

Traffic calming can be implemented either as a correction to observed high speeds or as an intentional feature on new and reconstructed streets. When implemented as a remedy for an observed speeding problem, they are frequently initiated in response to requests from the public. The process for selecting locations for traffic calming measures and choosing the appropriate measure is detailed in the Traffic Engineering and Operations Manual.

## **Geometry**

In many cases, street designs intended to reduce the likelihood of conflicts and crashes (such as wider lanes or gentler curves) actually encourage faster driving speeds, because they make drivers feel comfortable going faster. These overdesigned streets often result in more severe crashes. Accordingly, designers should seek to use geometric design to balance the risk of collisions with the potential severity of crashes.

### ***Design and Control Vehicles***

A related concept is the distinction between a “design vehicle” (the largest vehicle commonly expected on the street) and a “control vehicle” (the largest vehicle ever expected on the street). A typical design vehicle might be a smaller box truck, while a typical control vehicle might be a large combination freight truck, school bus, or fire engine.

Unlike the design vehicle, the control vehicle can use additional space for turning movements, including the adjacent and opposing travel lanes or mountable curbs, as shown in the figure below. Street designers should select the smallest appropriate design vehicle. This distinction allows designers to reduce the geometry of the roadway, especially by tightening curb radii, which will encourage slower speeds, shorten crossing distances, and improve comfort for pedestrians and bicyclists.

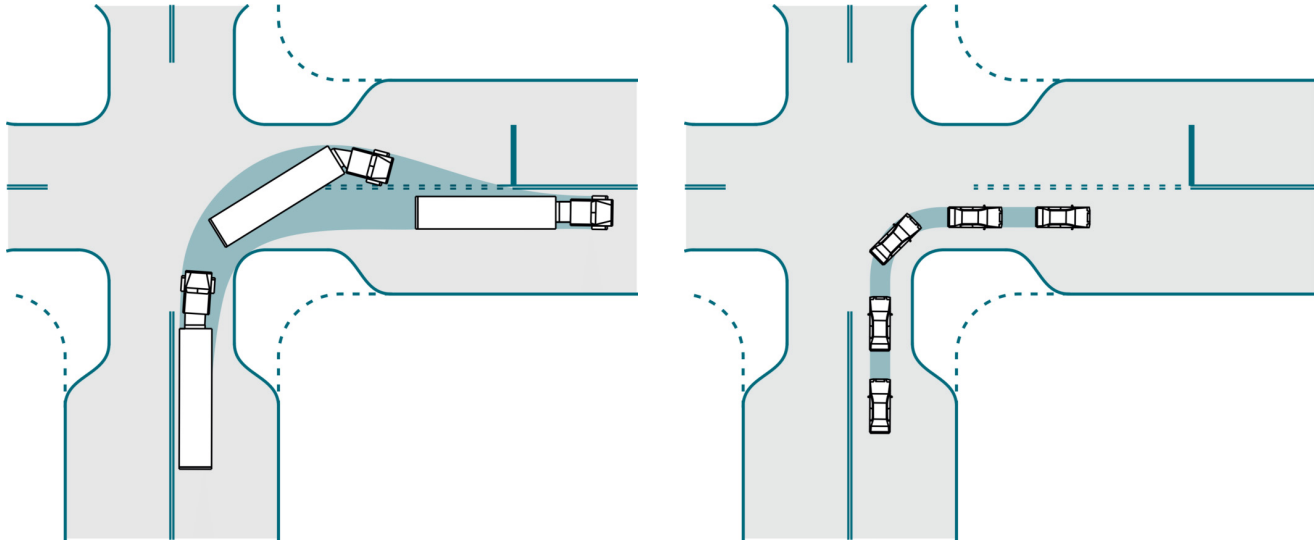

Source: NACTO Urban Street Design Guide (2013)

### **Effective Radius**

Designers should pay special attention to the effective radius of corners. Where vehicles are offset from the curb (by on-street parking or personal mobility lanes, for example), their effective turning radius will be much larger than the radius of the corner. Designers should minimize the effective radius to discourage high-speed turns.

### **Visibility**

#### **Sight Distance**

Allowing street users to see each other is essential to safety. Geometric design standards should accommodate required sight distance along vertical and horizontal curves and at intersections; however, changes in the built or natural environment can sometimes limit sight lines, increasing crash risk. Special care should be given to high-volume driveways, ensuring that sufficient sight distance is available to make all allowable movements. Areas where pedestrians stand waiting to cross the street should be visible to motorists and not blocked by signs, trees, poles, or parking.

#### **Lighting**

Crash rates are consistently higher under low-light conditions. In addition, lighting can deter crime and make vulnerable road uses feel more safe and secure. Intersection lighting and pedestrian-level corridor lighting are recommended in areas with transit, higher pedestrian and cyclists volumes, or unusual geometric or roadside conditions. Refer to the Traffic Engineering and Operations Manual and APWA 5800 for information on lighting design.

### **Conflict Points**

Conflict points are locations where street users cross paths. These locations hold the potential for severe collisions when users fail to perceive, react to, or obey signs and signals, or when such devices malfunction or are missing. As the number of lanes entering an intersection increases, so do conflict points, and as entering speeds increase, so do crash severities.

Designers should look for opportunities to manage conflict points by limiting right-angle crossing points. Roundabouts, for example, nearly eliminate the possibility of high-speed right-angle collisions and significantly reduce fatal and serious injuries. Features such as raised medians and split signal phasing can also help reduce conflict points, slow drivers down, and make decisions easier for all road users by limiting the number of hazards each person must evaluate before making stay-or-go decisions.

### ***Intersections***

Intersections present the most complexity and the greatest number of conflict points for all street users. In the most recent available crash data (2019-2023), crashes at intersections accounted for approximately 64% of all fatal and serious injury crashes in Kansas City. At all intersections, access and safety for the most vulnerable users should be prioritized. Pedestrians and cyclists should be made highly visible to motor vehicles, both through positioning in the driver’s field of vision and through appropriate lighting. At higher-volume, higher-speed intersections, mode separation in space or time (such as grade separated pedestrian crossings or pedestrian-only signal phases) may be appropriate.

Motor vehicle speeds should be managed near intersections to reduce the risk of severe crashes with pedestrians and cyclists. Improvements to signs and pavement markings that increase visibility or clarity for users can increase compliance with traffic control. Bike boxes and leading pedestrian intervals establish the presence of vulnerable users to motor vehicle drivers. Raised crosswalks and raised intersections can slow motor vehicles as they approach the intersection and make them more aware of the presence of other users.



*Figure 1 – Kansas City Vision Zero intersection improvements at Prospect Avenue and 31st Street. Improvements included high visibility crosswalks, pedestrian refuge islands and curb bump outs.*

## Pedestrian Crossings

Crossing safety for pedestrians is impacted by distance to the crossing from pedestrian traffic generators, street width, corner radius, sight lines, vehicle volume and speed, lighting, and consistency of driver and pedestrian expectations from one crossing location to the next.

Intersections in residential and neighborhood commercial areas, near schools and churches, near parks and recreation spaces, and in any other area where pedestrians may wish to cross the street should include well-marked crosswalks. Signalized intersections should provide sufficient time for pedestrians to cross the street at a comfortable pace; this pace will be slower for young children, older adults, and people using mobility assistance devices. Restricting right turns on red and using leading pedestrian intervals can help establish the presence of pedestrians and reduce the likelihood of them being struck in designated crossing areas at intersections.

To encourage pedestrians to use safe crossings, designers should take care to provide crossings at a reasonable frequency. Pedestrians often prioritize convenience when choosing a path to cross the street. If intersection crossings are spaced too far apart, pedestrians may choose to ignore them. In urban areas, crossings should generally be provided every 400–600 feet; however, appropriate crossing frequency will vary based on land use and specific pedestrian generators.

In many situations, midblock crossings should be provided. They should include highly visible pavement markings and advanced warning signs. Where volumes and/or speeds are higher, additional treatments, such as an actuated pedestrian signal, pedestrian hybrid beacon (PHB), or rectangular rapid flashing beacon (RRFB) may be appropriate.



Where mid-block crossings cannot be safely provided, consideration can be given to adding median treatments such as tall barriers and fencing that physically prevent or strongly discourage pedestrians from crossing away from intersections or other designated crossings.

Where crossings span multiple lanes in each direction of travel, or where signalization is not provided, a refuge island can improve safety by allowing pedestrians to break their crossing into two stages, which allows them to focus on one direction of approaching traffic at a time.

Pedestrian crossings should connect pedestrian paths; a crossing should never lead a pedestrian to a location without a sidewalk, trail, or multiuse path. However, the lack of pedestrian infrastructure does not suggest a crossing should not be provided—it suggests that additional infrastructure be built to support the pedestrian network.



## ***Lateral Separation of Modes***

Many pedestrians and cyclists are uncomfortable near fast-moving vehicles. Often, strategies to shield vulnerable road users from vehicles are limited by a constrained right-of-way. Designers can balance this by considering features that buffer vulnerable users from vehicles.

For example, if the minimum required buffer between curb and sidewalk cannot be provided, the presence of a personal mobility lane or on street parking might function as a buffer and make a reduced pedestrian buffer more acceptable. Similarly, on-street parking can be used as a buffer between a personal mobility lane along the curb and motor vehicle traffic. Designers should consider the speed of the roadway when selecting buffer types and widths. It is not appropriate to minimize buffer when pedestrians or cyclists are adjacent to high-volume or high-speed traffic.

Visual separation can also increase safety for vulnerable road users. Buffered personal mobility lanes with vertical delineators, for example, will likely be more comfortable than buffered personal mobility lanes without, even if the buffer width remains constant. For sidewalks especially, the buffer area should be visually distinct. If it is not practical to use a grassed/planted buffer, designers should consider alternate materials or, especially if space is restricted, a barrier (such as bollards). Where the full recommended width of sidewalk and buffer cannot be provided, designers should seek to provide some physical and visual buffer, even if it requires some minimal reduction of the sidewalk. As discussed, reducing travel lane width is preferred over reducing sidewalk or personal mobility lane width.

## ***Access Management***

Access type and density can vary significantly across street typologies, from limited-access freeways to full-access downtown streets. Street designers should be thoughtful about the placement of access drives, which represent conflict points for all users, especially when uncontrolled or near an intersection. On higher-volume streets, modifying internal traffic circulation, providing shared driveways, or adding access streets can limit or consolidate access points.

Access can be restricted with raised medians in the driveway (“pork chop islands”) that limit specific movements or with raised medians in the major road, which can have the same effect while providing refuge for crossing pedestrians and calming adjacent traffic.

Where continuous medians are used, U-turn lanes and roundabouts can provide opportunities for drivers to change directions and access destinations on the other side of the street. While two-way left-turn lanes are acceptable, medians with structured turning movements are preferred. The design should support turning speeds of under 15 mph.

On very low-volume streets, frequent access points can signal to drivers that slower speeds are required to accommodate entering and exiting traffic.

## Considerations for Street Designers

Street design should match the context of the roadway, including its users, its relationship to the transportation network, the current and future adjacent land use, nearby population density and demographics, desired aesthetic, and community priorities. The following are important considerations for designers as they make choices.

### Connectivity

Connectivity indicates how conveniently and comfortably users can travel to their desired destinations. Accommodation for modes or user groups, such as personal mobility lanes or bus lanes, should not be considered individually for each project, but instead in a coordinated manner across the network. When the transportation system provides a connected and convenient network for each user group, it encourages a stratification of modes that makes it easier to accommodate each of them safely.

As new development occurs, providing multiple routes between origins and destinations will improve the connectivity and resilience of the network. Frequent connections allow for easier mobility when a street is closed, and multiple paths reduce demand on any given route, allowing for fewer lanes.

### Timescale

Remaining design life, as well as pavement condition, may impact the types of treatments that are considered for a specific corridor. If a street is likely to be replaced in the short term, temporary improvements may be preferred in the interim. Temporary improvements can be an effective tool to make a street safer while reducing costs. They also provide an opportunity to generate feedback from the public and make adjustments to address any unforeseen concerns before installing permanent infrastructure. The following are common examples of temporary treatments:

- curb corners extended with planters or paint and vertical delineator posts
- prefabricated speed humps and tables
- trailer-mounted speed feedback signs



When estimating trip generation in future years, designers should consider the potential for modal shift away from vehicle trips. The Kansas City Climate Protection and Resiliency Plan includes strategies to shift trips to bicycling, walking, and transit trips by expanding networks for these modes. This Streets Design Guide provides guidance to support the implementation of these strategies.

Wider than necessary streets lead to higher speeds and potentially dangerous conditions for vehicles and vulnerable users. Instead, where growth is anticipated, street designers should purchase right-of-way for the future projected need while restricting the initial street to the fewest lanes needed. The street should be built to one side of the right-of-way to reduce the need to relocate utilities and drainage in the future. Medians

and adjacent shared use paths can be built on the remaining right-of-way until traffic volumes warrant additional lanes.

### Level of Service

Level of Service (LOS) has historically been a quantitative assessment of vehicle speed, delay, and congestion. LOS for motor vehicles ranges from A, in which vehicles have minimal delay and can freely travel at or above the speed limit to F, in which vehicles experience “breakdown” congestion (i.e. stop-and-go conditions).

This measure focuses on driver comfort and convenience; however, Level of Service A is associated with a higher crash rate than LOS C or D. Conditions that constrain free flow speed and require drivers to be more attentive when changing lanes or making turning maneuvers can reduce the frequency and severity of crashes. Moderate traffic flows with limited speeds (LOS C and D) tend to have the lowest crash rates.

Research conducted for Kansas City’s Vision Zero Action Plan shows the relationship between congestion and fatal and serious injury crash risk. Streets with lower volume-to-capacity ratios were consistently more likely to experience fatal and serious injury crashes.

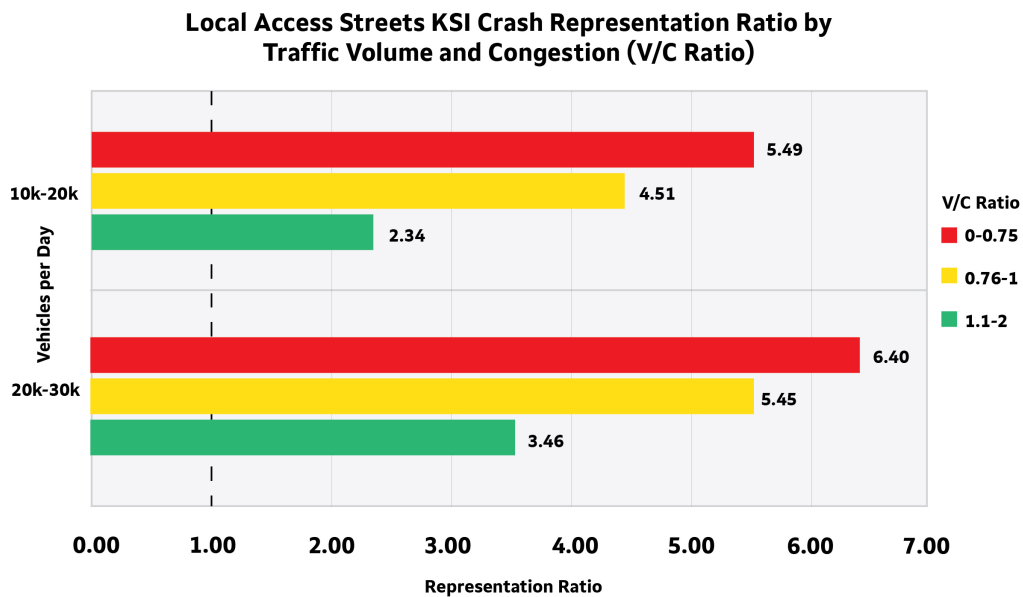

Figure 2 – Crash Representation Ratio by V/C Ratio (See KCMO VZ Action Plan Page 47)

Newer metrics such as Pedestrian Level of Service (PLOS) and Bicycle Level of Service (BLOS) can measure the comfort and convenience of other user groups. The Level of Service of Safety (LOSS) is a measure of a street’s safety performance, comparing its observed crash history to predicted crashes for a street with similar characteristics. To meet City Vision Zero and Complete Streets goals, **these measures should take precedence on City streets over the traditional LOS measure for motor vehicles.** Additional guidance for determining LOS for all modes is provided in Sections 2.3 and 2.4 of the Highway Capacity Manual and the Federal Highway Administration (FHWA) Guidebook for Developing Pedestrian and Bicycle Performance Measures.

In addition to these quantitative metrics, designers should use surveys, walk audits, and other

engagement strategies (either in coordination with a project or on a regular basis) to provide insight into the experience of street users and to improve a street's perceived level of service.

## **Human Factors**

How well a street operates is determined by how well users understand and comply with its intended use. Human factors describe how roadway users perceive and react to information in their environment and are impacted by sight distance; lighting; sign spacing, size, and reflectivity, marking visibility, placement, and design; clear zone width; fixed object type and density; speed and volume of traffic; and other elements of the roadway environment.

Especially at complex intersections, street designers should take care to minimize driver workload and maximize clarity of expectations. Best practices include providing sufficient sight distance, proper lighting, retroreflective signs and markings, wayfinding guidance, and consistency in street cross-section and traffic control.

In other locations with lower complexity—where drivers can be prone to inattentive driving—it may be helpful to introduce elements that require drivers to pay more attention to their speed. Signs and striping can be used to make drivers more aware of their speed in relation to the roadway context. Design elements like lane shifts, pinch points, and mini roundabouts can be used on low-speed routes to help drivers maintain focus.

## **Equity**

The Kansas City, Missouri (KCMO) Vision Zero Action Plan identifies clear inequity in the transportation system, especially with respect to safety. Black residents face the highest risk of death and serious injury on Kansas City streets.

Historically, disadvantaged communities have been disrupted or destroyed by the development of the transportation system. These populations are still exposed to streets that endanger vulnerable users and adversely affect their health with noise and pollution. In response, street designers must take special care to include neglected perspectives and consider how the costs and benefits of their project are distributed.

## **Land Use and Placemaking**

The development surrounding a corridor defines the purpose and activity of the street. The density of development increases as you move from rural areas with large lots and low activity; through suburban areas with higher activity and single use development; and into the urban core with high levels of street activity, mixed use developments, and shorter block lengths. These factors influence modes of travel and uses of the public right-of-way.

Streets contribute to a sense of place. Landscaping, human-scale lighting, art, and furniture along the street can add value to adjacent development. By contrast, harsh lights, noise, and high vehicle speeds can depress value. Street design tells users who is welcome and can support or discourage foot traffic, bicycling, recreational trips, and deliveries. Pleasant streets for all users are economic engines: they attract customers and connect businesses to the freight network.

## Sustainability and Climate Resilience

More than 30% (2.9 million MTCO<sub>2</sub>) of Kansas City's greenhouse gas emissions come from motor vehicles. The City's Climate Protection and Resiliency Plan established multiple goals regarding mobility, including:

1. Reducing vehicle miles traveled
2. Shifting trips to lower emissions options
3. Reducing idling and congestion
4. Increasing transit trips

Designers should approach street projects with a sustainability focus. Broadly, streets should be designed to promote more transit, walking, and bicycle trips to improve local air quality. On a smaller scale, individual devices (for lighting, signaling, etc.) should use solar power where possible. During construction, designers should seek opportunities to preserve pavement and incorporate recycled materials.

Street designers should also consider how each street interfaces with natural systems, including weather, wildlife, and environmental landmarks. It is increasingly important that our infrastructure is resilient to both acute natural disasters and more gradual changes in climate. Kansas City expects increasing rainfall volumes, which will further tax the existing combined sewer infrastructure and worsen water quality. Kansas City also expects higher average temperatures and more frequent heat waves.

A key component of resiliency is green stormwater infrastructure. Designers can use simple strategies (such as curb cuts or trench drains) to bring water that would otherwise be treated as waste to street trees and native landscaped areas. Additionally, larger excavations, improved soil media, and proprietary soil cell systems will enhance the health and longevity of street trees. Landscaped areas also help to reduce urban heat island effects. Green stormwater infrastructure may also be referred to as post-construction stormwater, best management practices, stormwater control measures, nature-based solutions, or stormwater treatment facilities.

The City of Kansas City, Missouri, established a Climate Protection and Resiliency Plan in 2022. Several strategies included in the plan can be achieved through pursuing complete street design such as expanding the network of trees (Strategy N-1) and using natural systems to manage stormwater runoff (Strategy N-4). Street features that manage water—including swales and planted elements—can make the street more attractive while managing increased rainfall. Where possible, street designers should minimize the use of impervious surfaces. Both strategies build resilience to extreme heat and flooding.

## CLIMATE ACTION SECTIONS AND STRATEGIES



### MOBILITY

**M-1: Reduce vehicle miles traveled (VMT) through coordinated and planned development**

**M-2: Shift trips to bicycling and walking by expanding a network of safe and accessible routes**

**M-3: Shift trips to transit by building efficient and effective transit systems and mobility hubs**

**M-4: Reduce vehicle emissions from idling by reducing congestion and improving parking management**

**M-5: Reduce vehicle emissions through low- and no-emission vehicles**

*Source: KCMO Climate Protection & Resiliency Plan*



# Street Typologies



Street typologies are categories used to define streets by their function, design and usage. This section provides the definitions, characteristics and cross sections for the following street typologies:

- Downtown Core
- Urban Mixed Use
- Suburban Commercial
- Thoroughfare
- Connector
- Neighborhood
- Industrial / Business Park
- Boulevards
- Parkways

The street typologies in this section of the Streets Design Guide correspond to an online, interactive Streets Design Guide Map, which assigns each street in Kansas City to a typology. This map can be found on the City's website at [\[PLACEHOLDER URL\]](#)

Each street typology will have a unique approach to the allocation of space. While the building environment limits the available right-of-way, the existing right-of-way can be redistributed to satisfy the changing needs of a community or neighborhood.

When considering how to allocate available right-of-way, the priority is the safety of vulnerable road users because pedestrians and cyclists are more vulnerable to serious injuries than drivers when involved in a crash. The next is accommodating other user groups in accordance with established personal mobility (bike) and transit networks. This can sometimes mean reducing the number or width of standard travel lanes to provide pedestrian space, personal mobility lanes, transit lanes, or medians.

When allocating right-of-way, City goals of reducing traffic fatalities, reducing carbon emissions by encouraging mode shift to reduce miles traveled by single-occupancy passenger cars, and increasing healthy communities should be prioritized.

The space adjacent to street curbs can be used for motor-vehicle parking, ride-share loading and unloading, transit stops, bikeshare parking, electric vehicle charging, deliveries, green stormwater infrastructure, and public spaces like street cafes. Each of these amenities can contribute to access, placemaking and safety. Decisions about curbside management should be made to align with the street typology and adjacent development, providing flexibility to allow changes as needs change. Motor vehicle traffic should be slower near areas with heavy curbside activities and these zones should be made visible to approaching traffic.

## Elements of Design

Each typology provides a table of key characteristics. Definitions for these characteristics and other terms included in this section are defined in the table below.

Target Speed	The highest speed at which vehicles should operate in a specific context. Target speed, design speed, and posted speed should be equal.
Design Vehicle	The largest vehicle that is likely to use the facility with considerable frequency, whose selection will determine road geometry. See the following page for examples of design vehicles.
Control Vehicle	The largest vehicle that will infrequently use the street.
Right-of-Way Width	Public space designated for travel. On established streets, this space is typically fixed. For new construction, designers should refer to the recommended ranges for a particular typology.
Lane Width	The width of travel lanes.
Pedestrian Facilities	Pedestrian facilities, generally known as the sidewalk, is the space allocated for pedestrians between the street curb and the edge of the right-of-way, which includes both the pedestrian and amenity zone. The "pedestrian zone" space is allocated to unobstructed pedestrian through movement. The "amenity zone" includes landscaping, green infrastructure, utilities, transit stops, loose furnishings or street furnishing zone in the area between the street and the "pedestrian zone."
Curbside Uses	Utilities, amenities, landscaping, transit stops, or green stormwater infrastructure that occupy the curbside use within the roadway space occupied by vehicles.
Micromobility Facilities	Space allocated for the operation of bicycles and other micromobility devices (scooters, etc.), which may be separated from or shared with motor vehicles and other modes.
Transit Facilities	Space allocated for transit services, either within the roadway or at the curb.
# of Travel Lanes	The number of lanes for vehicle through movement.
Parking	Space within the ROW allocated for motor vehicle parking. This may include parallel, angled, reverse-angled (preferred to angled), or traffic lanes designated for parking during certain days/times.
Green Stormwater Infrastructure	A holistic approach to stormwater management that collects and stores rainwater where it falls by mimicking the natural water cycle. Guidance for stormwater infrastructure is in the KCMO Green Stormwater Design Guide. Trees and landscaping present can help reduce the urban heat island effect.
Street Activation	The level of activity between pedestrians and buildings along the street.
Place Type	The land use character typically adjacent to the street.
Access Control	Restrictions on driver movements, especially with driveways that intersect the street. This may also include raised medians or signage.

Street Typology	Vehicle Type
-----------------	--------------

Neighborhood  
Boulevards  
Parkways

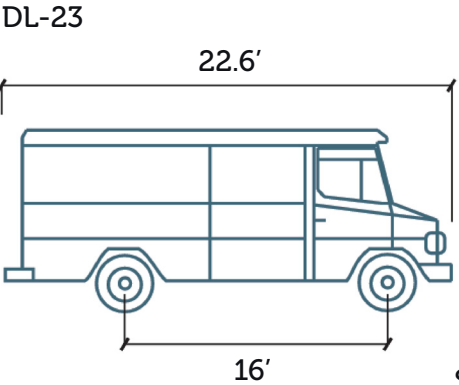

Source: NACTO

Downtown Core  
Urban Mixed Use  
Suburban Commercial  
Thoroughfare  
Connector

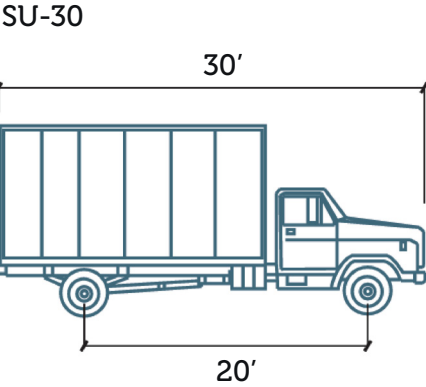

Source: NACTO

Industrial / Business Park

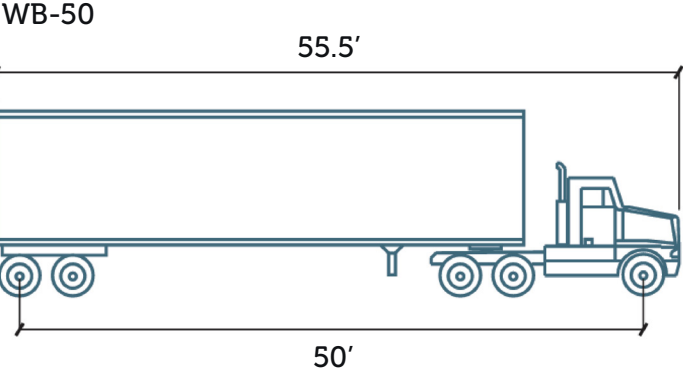

Source: NACTO

# Downtown Core

Downtown Core streets fall within areas of high development density such as a central business district. They accommodate low motor vehicle speeds, high pedestrian volumes, enhanced transit connections, and freight delivery activity. See Area Plans [areaplans.kcmo.gov](http://areaplans.kcmo.gov) and KC Spirit Playbook for more information.

Many downtown core streets have been studied in the past. These previous studies should be heavily considered when looking at those particular streets. Here is a list of known studies that represent downtown core streets.

- River Market streetscape plan
- West Bottoms
- Downtown Loop streetscape plan
- Two-way conversion study 2024 – 7th Street, 8th Street, 9th Street, 10th Street
- Grand Boulevard - Making Grand Grand - 2011

## ***Downtown Core Example Streets***

Most streets within the downtown loop fit in the Downtown Core typology, including:

- 10th Street
- 11th Street
- 12th Street
- 13th Street
- 14th Street
- Oak Street
- Walnut Street
- Main Street
- Baltimore Avenue
- Wyandotte Street
- Central Street

### ***Downtown Core Key Characteristics***

Target Speed	20 mph
Design Vehicle	SU-30
Control Vehicle	Aerial Fire Truck MM100
Right-of-Way Width	50'–100'
Lane Width	11' or 10' if no bus in the lane
Pedestrian Facilities	Pedestrian zone - 10'+ sidewalk preferred, 6' minimum, amenity zone - 4' minimum.
Curbside Uses	Loading zones, pedestrian amenities, bicycle parking, transit stops
Micromobility Facilities	Sharrows allowed under 15 mph / standard personal mobility lanes < 6,000 vpd / buffered or separated lanes ≥ 6,000 vpd, separate from sidewalk space
Transit Facilities	Transit service is very likely on Downtown Core streets. Refer to "Accommodation for Transit Vehicles" under Design Guidance.
# of Travel Lanes	2 for streets < 20,000 vpd, otherwise 4
Parking	<p>On-street parking is allowed, both full-time and off-peak. Parking rates should be charged to encourage turnover. Reverse-angled parking is preferred, but angled or parallel parking is also allowed. Angled parking must be reverse-angle on one-way streets.</p> <p>Freight vehicles often use street space for unloading on downtown core streets. If only two travel lanes are provided, designers should designate parking space for freight unloading.</p>
Green Stormwater Infrastructure	Native plantings in buffer areas or medians and street trees. Rain gardens in curb extensions or combined with street furniture
Street Activation	High level of street activation including heavy pedestrian, bicycle, and shared mobility travel; street vendors, street cafes; and parklets.
Place Type	Downtown Core, Downtown Mixed Use
Access Control	Driveways should be heavily restricted. Drive aprons shall be designed at their minimum width.

# DOWNTOWN CORE

This conceptual roadway diagram illustrates a range of possible segments for the given street typology and is not intended to represent a continuous roadway condition.

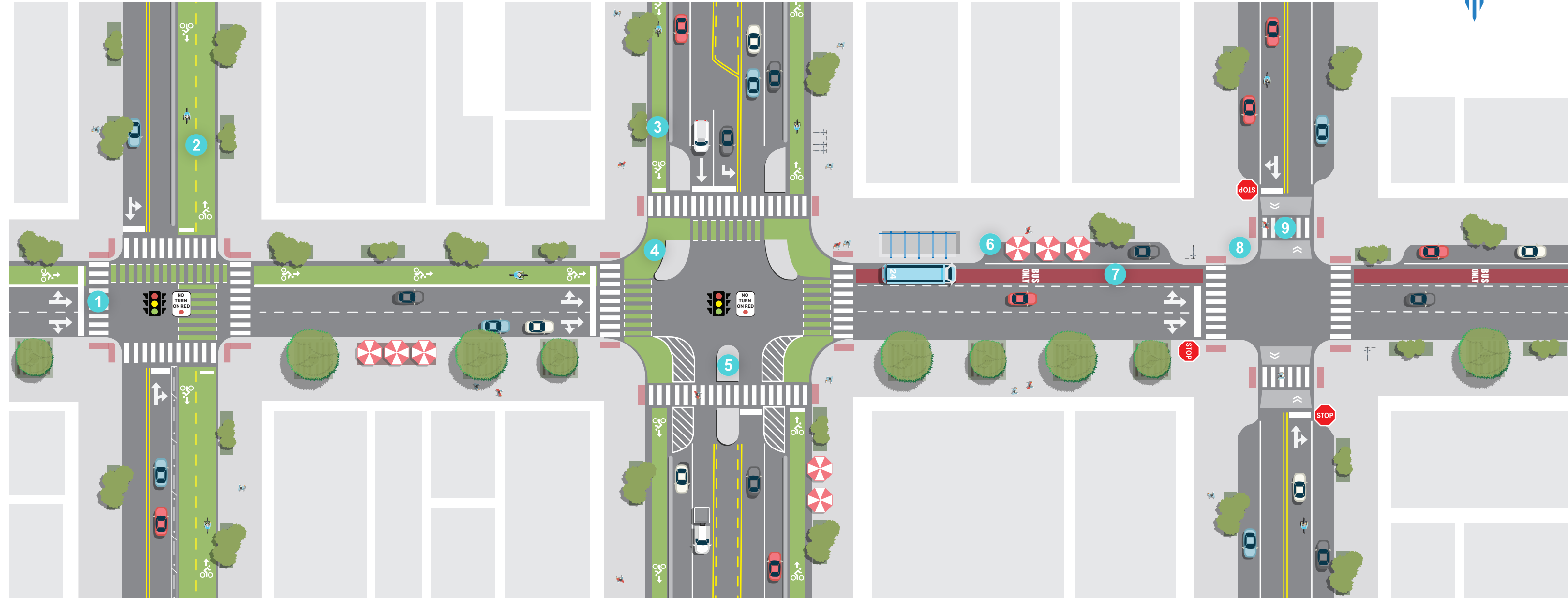

- 1 HIGH VISIBILITY CROSSWALK**  
A crosswalk that provides increased visibility to motorists through high-visibility pavement markings, signing, and lighting.
- 2 TWO-WAY CYCLE TRACK**  
Separated bike lanes that allow bicycle movements in both directions on one side of the street.
- 3 PROTECTED BIKE LANE**  
Protected mobility lanes that provide a physical barrier between bicycle and vehicle traffic. Vertical elements like concrete curbs also provide a visual barrier.
- 4 PROTECTED INTERSECTION**  
Intersections that provide separated paths for bicyclists, pedestrians and vehicle traffic and that provide physical protection, improve visibility, and reduce crossing distances for bicyclists.
- 5 PEDESTRIAN REFUGE ISLAND**  
A median with a refuge area that provides pedestrians a protected area to cross a multilane road in two stages if necessary.
- 6 PARKLET**  
Public seating platforms that convert curbside parking spaces into lounge, dining, and/or community space. These are often used to provide additional space in the pedestrian realm.
- 7 TRANSIT**  
Dedicated transit lanes that improve throughput of buses and reduce vehicle weaving on corridors. These lanes may sometimes be shared by bicyclists and/or right turn vehicles. Bus shelters are appropriate along transit lanes.
- 8 CURB EXTENSIONS**  
Curblines extended into the street, either with concrete or paint, at crossing locations to reduce the crossing distance for pedestrians, make pedestrians more visible to motorists, and provide space for street furniture, lighting fixtures, and traffic signal equipment.
- 9 RAISED CROSSWALK**  
Crosswalks that are elevated (similar to a speed hump or table) that limit turning speeds of vehicles and increase the visibility of crossing pedestrians.

## ***Downtown Core Cross Section Options***



**80-foot ROW: Two-way segment with center turn lane, parking lanes, and separated mobility lane on both sides**



**60-foot ROW: One-way segment with transit-only lane and separated two-way mobility facility**

***Downtown Core Cross Section Options***

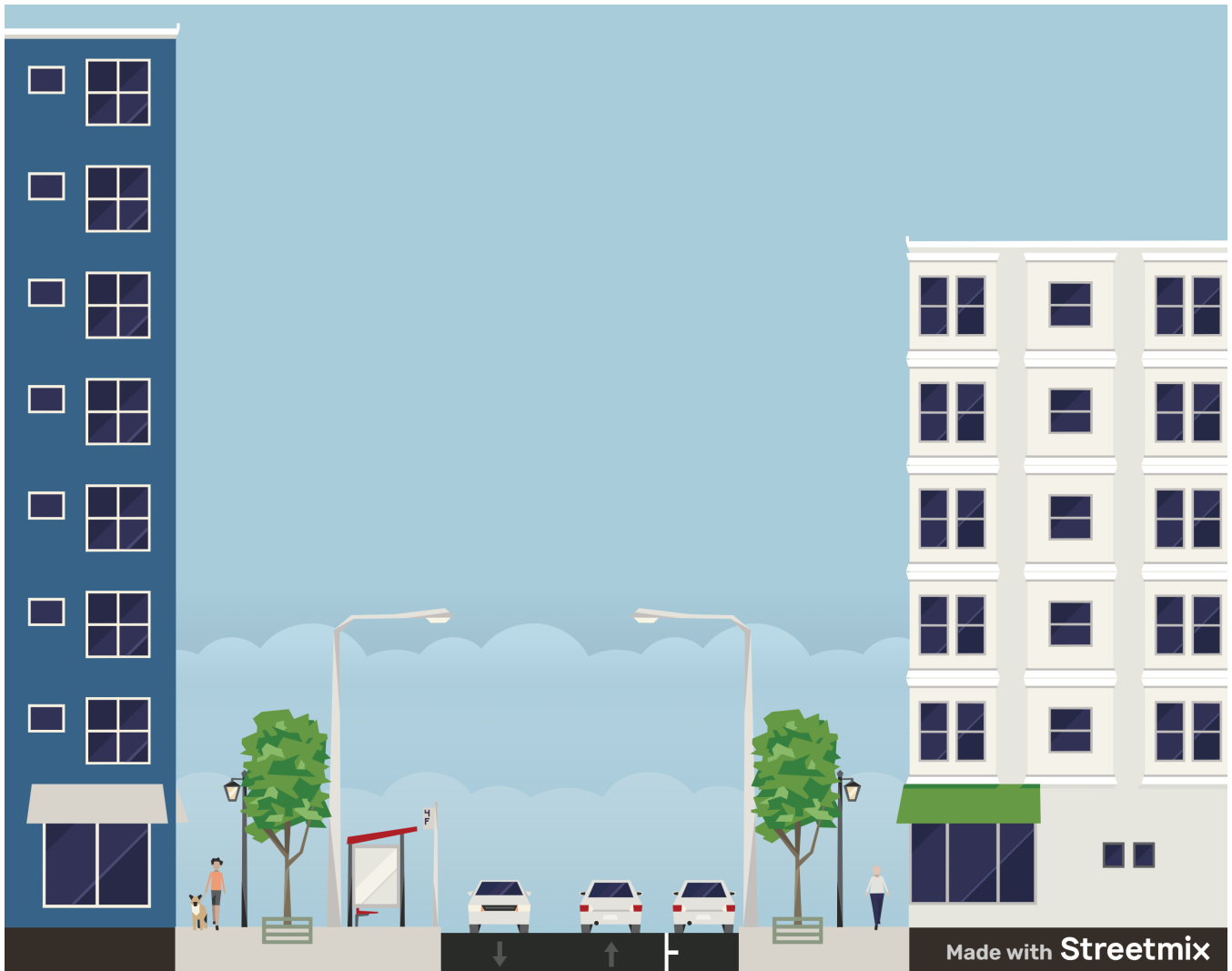

60-foot ROW: Two-way segment with parking

# Urban Mixed-Use

Urban Mixed-Use streets are neighborhood-level commercial corridors outside of the central business district providing access to high-level trip generators such as retail, office, and restaurant space. These areas have a defining character and typically have a historic significance for the local community. The corridors are typically dense and walkable.

## *Urban Mixed-Use Example Streets*

- 63rd Street between Wornall Road and Troost Avenue
- 39th Street from State Line Road to Gillham Road
- 31st Street from Oak Street to Troost Avenue
- 75th Street between Pennsylvania Avenue and Main Street

### **Urban Mixed-Use Key Characteristics**

Target Speed	25 mph
Design Vehicle	SU-30
Control Vehicle	Aerial Fire Truck MM100
Right-of-Way Width	80'–120'
Lane Width	10' minimum; 11' when bus is present in that lane
Pedestrian Facilities	Pedestrian zone - 10'+ sidewalk preferred, 6' minimum, amenity zone - 4' minimum.
Micromobility Facilities	Buffered or separated lanes, separate from sidewalk space
Curbside Uses	Pedestrian amenities, bicycle parking, transit stops, landscaping
Transit Facilities	Transit service is very likely on Urban Mixed-Use streets. Refer to "Accommodation for Transit Vehicles" under Design Guidance.
# of Travel Lanes	2 for streets < 20,000 vpd, otherwise 4
Parking	On-street parking is allowed, both full-time and off-peak. Parking rates should be charged to encourage turnover. Reverse-angled parking is preferred, but angled or parallel parking is also allowed.
Green Stormwater Infrastructure	Native plantings in buffer areas or medians and street trees. Rain gardens in curb extensions or combined with street furniture
Street Activation	High level of street activation including heavy pedestrian, bicycle, and shared mobility travel; street vendors, street cafes; and parklets.
Place Type	Commercial, Mixed-Use Community, Mixed-Use Neighborhood, Mixed-Use Neighborhood, Mixed-Use Residential, Regional Center (RC), Community Center (CC), Neighborhood Center (NC)
Access Control	Driveways should be minimized by promoting local access roads, shared drive access, right-in/right-out only, and/or minor street access. Access for major generators should be evaluated for appropriate traffic control treatments. Drive aprons shall be designed at their minimum width.

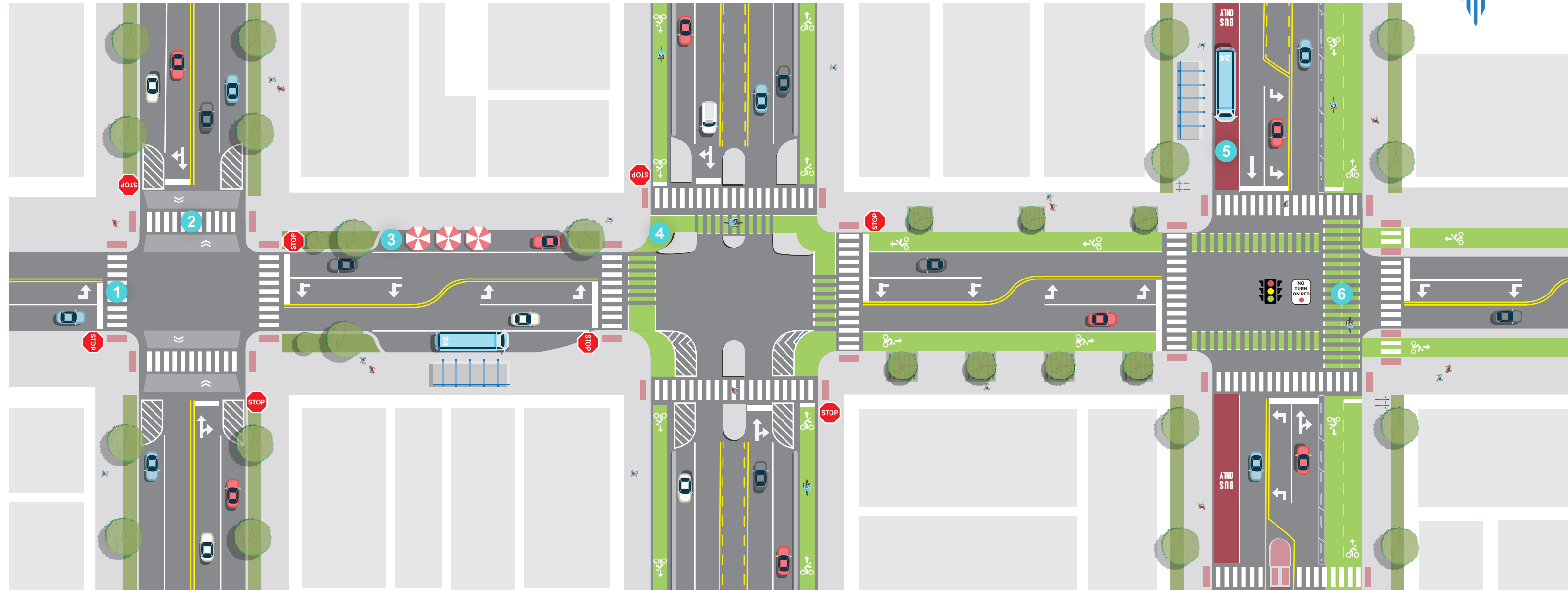

**1 HIGH VISIBILITY CROSSWALK**  
Using continental crosswalk marking increases the visibility of a crosswalk to motorists.

**2 RAISED CROSSWALK**  
Raised crosswalks limit turning speeds of vehicles and increase the visibility of crossing pedestrians.

**3 PARKLET**  
Public seating platforms that convert curbside parking spaces into lounge, dining, and/or community space. These are often used to accommodate needed space in the pedestrian realm.

**4 PROTECTED INTERSECTION**  
Protected intersections provide physical separation between bicyclists and vehicle traffic, improving sightlines, reducing crossing distances, and providing predictable movements through an intersection.

**5 TRANSIT**  
Dedicated transit lanes that improve throughput of buses and reduce vehicle weaving on corridors. These lanes may sometimes be shared by bicyclists and/or right turn vehicles. Bus shelters are appropriate along transit lanes.

**6 BIKE INTERSECTION MARKINGS**  
Green painted crossing that increase the awareness of motorists that bicycles may cross at this location. These marking also provide wayfinding for bicyclist.

**Urban Mixed-Use Cross Section Options**

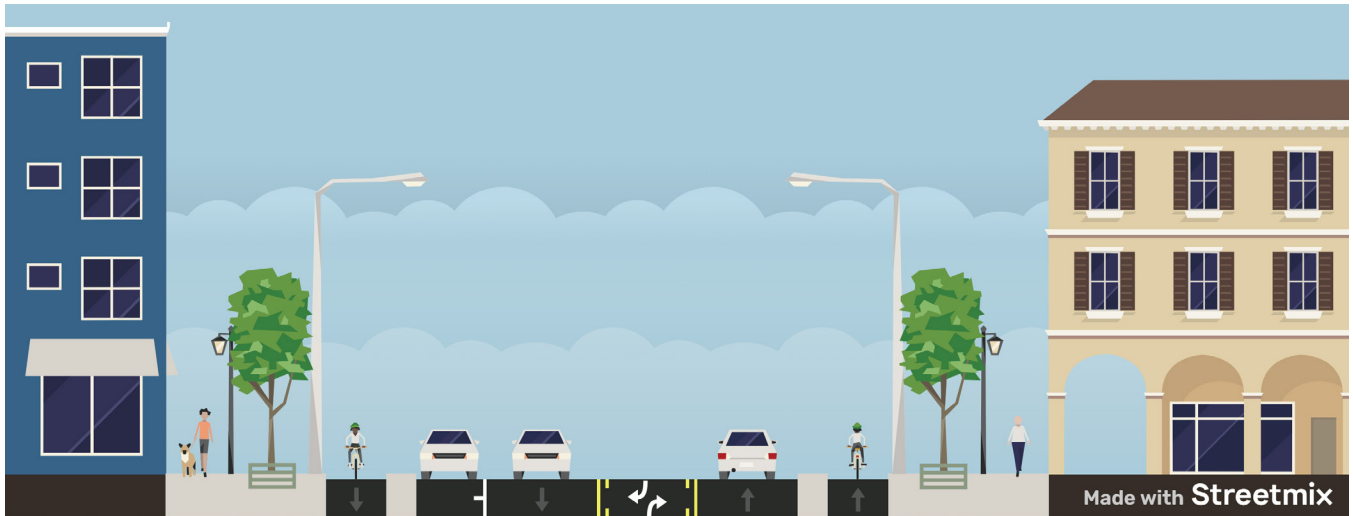

80-foot ROW: Two-way segment with center turn lane, parking lane on one side, and separated mobility lane on both sides

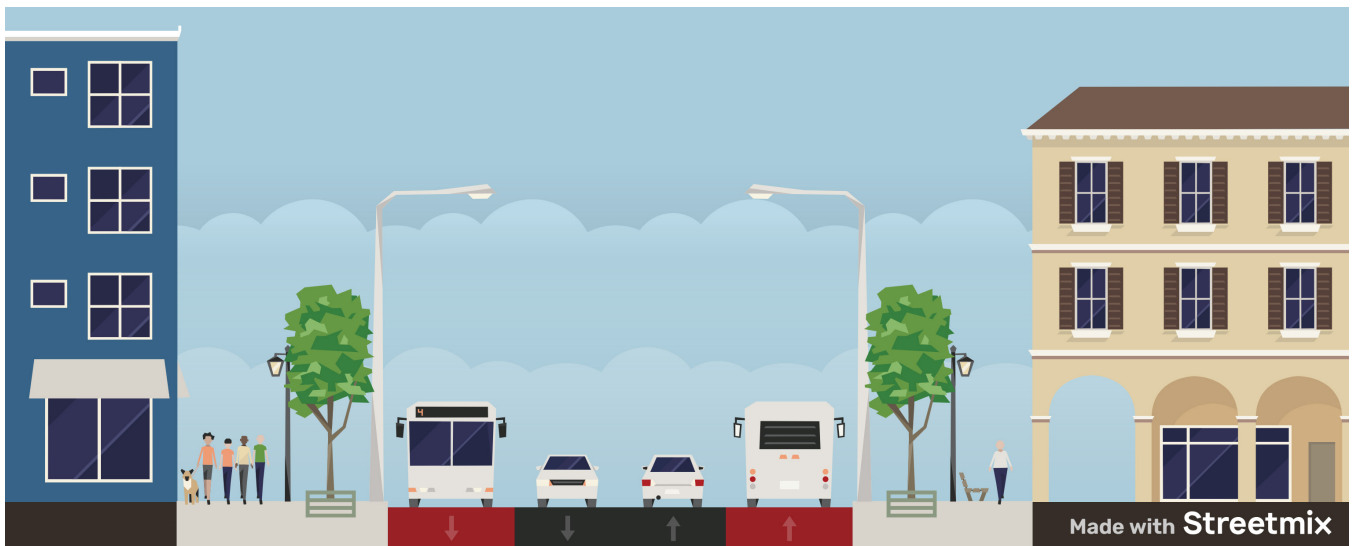

80-foot ROW: Two-way segment with transit-only lane on both sides

**Urban Mixed-Use Cross Section Options**

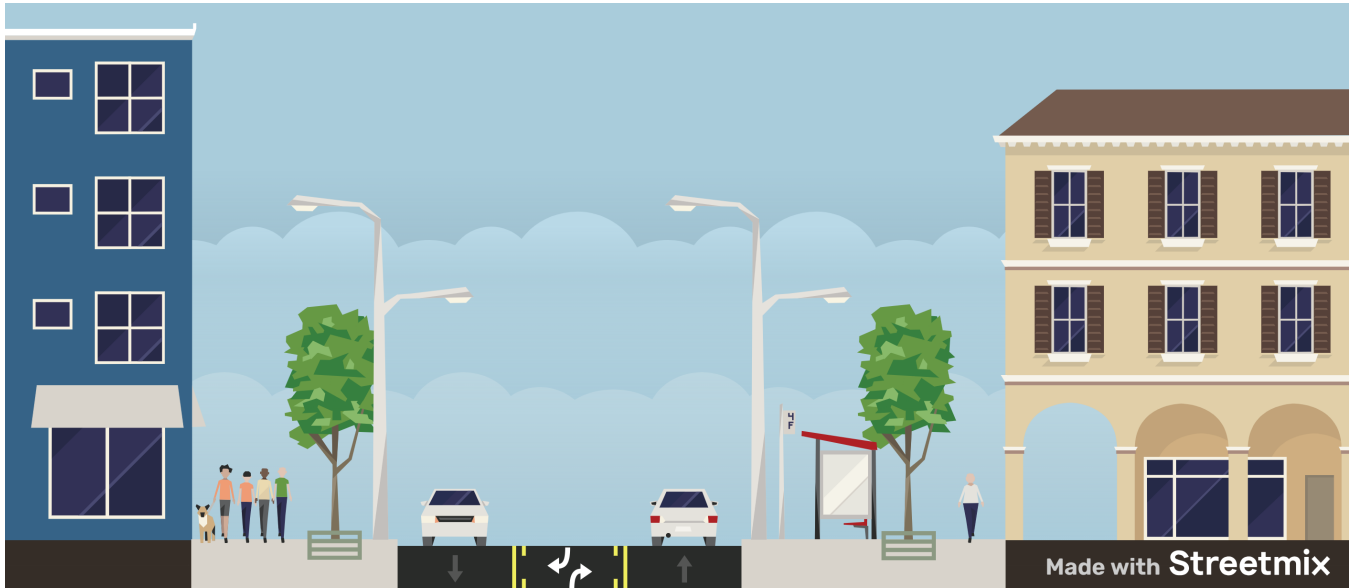

60-foot ROW: Two-way segment with center turn lane



60-foot ROW: Two-way segment with parking lane on both sides

# Suburban Commercial

Suburban commercial streets are heavy commercial corridors with standard suburban style commercial development. This may include malls, strip retail centers, drive-thru restaurants, gas/oil/tire stations, car washes, and other businesses.

## *Suburban Commercial Example Streets*

- NW Prairie View Road
- N Ambassador Drive
- N Boardwalk Avenue
- N Oak Trafficway
- Wyandotte, Washington Street and Madison Avenue in Martin City

### **Suburban Commercial Key Characteristics**

Target Speed	25 mph
Design Vehicle	SU-30
Control Vehicle	Standard Pump Fire Truck
Right-of-Way Width	80'–120'
Lane Width	10' minimum; 11' when bus is present in that lane
Pedestrian Facilities	Pedestrian zone - 10' minimum, amenity zone - 4' minimum and is typically green space.
Curbside Uses	Landscaping, wayfinding, and transit stops
Micromobility Facilities	Separated mobility lanes with a preference for being at sidewalk level. Shared use path with 12' width preferred.
Transit Facilities	Transit service is possible on Suburban Commercial streets. Refer to "Accommodation for Transit Vehicles" under Design Guidance.
# of Travel Lanes	2 for streets < 20,000 vpd, otherwise 4
Parking	No on-street parking
Green Stormwater Infrastructure	Native plantings in buffer areas and street trees placed behind the sidewalk
Street Activation	Low
Place Type	Open Space/Buffer, Commercial, Mixed Use Community, Mixed Use Neighborhood, Mixed Use Residential, Residential High, Residential Medium, Residential Low, Business Center (BC, IF, CC, NC, N3, N2)
Access Control	Driveways should be minimized by promoting local access roads, shared drive access, right-in/right-out only, and/or minor street access. Access for major generators should be evaluated for appropriate traffic control treatments. Drive aprons shall be designed at their minimum width.

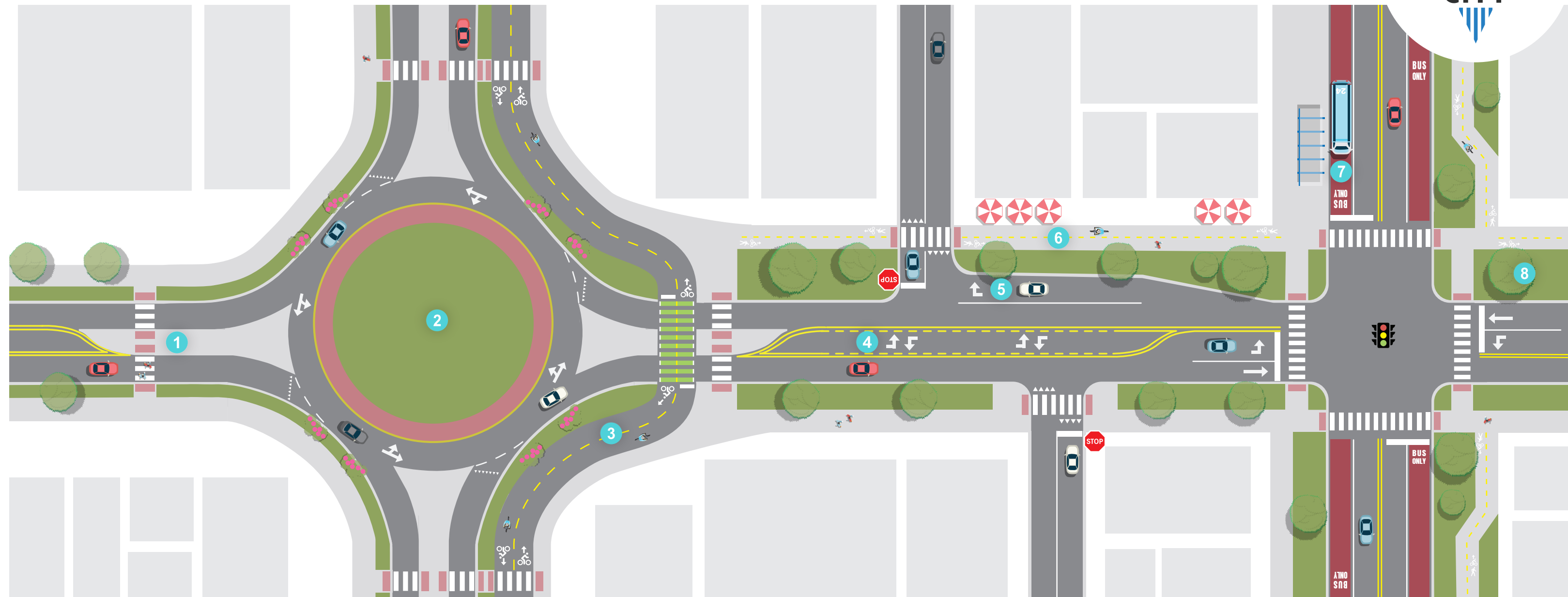

**1 PEDESTRIAN REFUGE ISLAND**  
A median with a refuge area that provides pedestrians a protected area to cross a multilane road in two stages if necessary.

**2 ROUNDABOUT**  
Circular intersection that reduces vehicle speeds, improves traffic flow, and lowers the risk of serious right-angle collisions compared to traditional intersections.

**3 TWO-WAY CYCLE TRACK**  
Separated bike lanes that allow bicycle movements in both directions on one side of the street.

**4 TWO-WAY LEFT-TURN LANE**  
Center lane that provides separation between left-turning traffic and through traffic in areas with high density of access points. Allows drivers to make turns in two stages and wait for appropriate gaps.

**5 RIGHT-TURN LANE**  
Auxiliary lane that provides space for right-turning vehicles to slow before turning onto a side street or driveway. Can reduce rear-end crashes.

**6 SHARED USE PATH**  
A wide path designed for pedestrians, cyclists, and other non-motorized travelers that promotes safe, active transportation away from traffic.

**7 TRANSIT**  
Dedicated transit lanes that improve throughput of buses and reduce vehicle weaving on corridors. These lanes may sometimes be shared by bicyclists and/or right turn vehicles. Bus shelters are appropriate along transit lanes.

**8 WIDE BUFFER AREA**  
The shoulder and green space provide a wide buffer between heavy vehicles and pedestrians and cyclists.

**Suburban Commercial Cross Section Options**

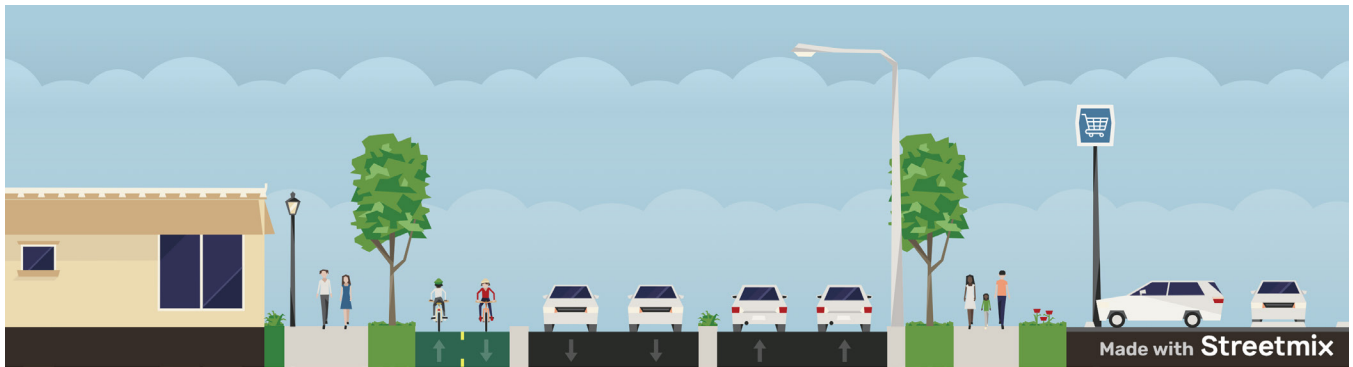

100-foot ROW: Two-way segment with median and protected two-way mobility lanes



120-foot ROW: Two-way segment with median and transit facilities on both sides

**Suburban Commercial Cross Section Options**



120-foot ROW: Two-way segment with center turn lane and separated two-way mobility lanes

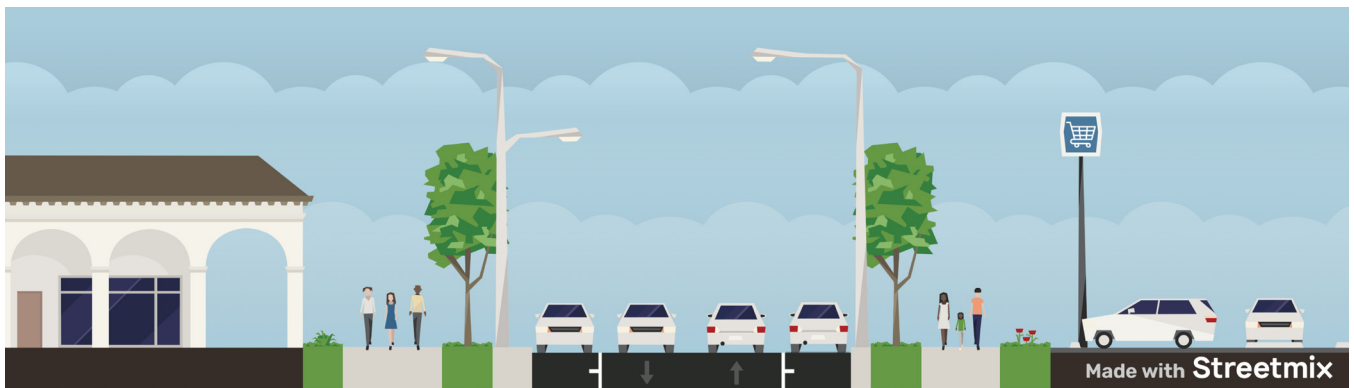

100-foot ROW: Two-way segment with parking lane on both sides

# Thoroughfare

Thoroughfares are longer corridor streets that connect major areas with limited access. They serve through trips and generally meet the definition of arterials.

## *Thoroughfare Example Streets*

- Bannister Road East of I-435
- Troost Avenue South of 75th Street
- 63rd Street Trafficway east of Swope Parkway
- Southwest Trafficway
- NE Antioch Road

### Thoroughfare Key Characteristics

	Typical	Rural Context
Target Speed	30 mph	40–50 mph, depending on access density
Design Vehicle	SU-30	Same
Control Vehicle	Standard Pump Fire Truck	Same
Right-of-Way Width	100'–120'	50'–80'
Lane Width	11'; 12' when used by heavy trucks	Same
Pedestrian Facilities	Pedestrian zone - 10' Amenity zone - 5-8' minimum and is typically green space	Shared use path
Curbside Uses	Landscaping, wayfinding, and transit stops	NA
Micromobility Facilities	Separated mobility lanes	Shared use path
Transit Facilities	Transit service is likely on Thoroughfare streets. Refer to "Accommodation for Transit Vehicles" under Design Guidance.	N/A
# of Travel Lanes	2 for streets < 20,000 vpd, otherwise 4	Same
Parking	No on-street parking	Same
Green Stormwater Infrastructure	Native plantings in buffer areas and street trees placed behind the sidewalk	Ditch
Street Activation	Low	Very Low
Place Type	Light Industrial, Commercial (IF, BC)	Agricultural
Access Control	Driveways should be minimized by promoting local access roads, shared drive access, right-in/right-out only, and/or minor street access. Access for major generators should be evaluated for appropriate traffic control treatments. Drive aprons shall be designed at their minimum width.	Access points should be provided where adequate site distance exists.

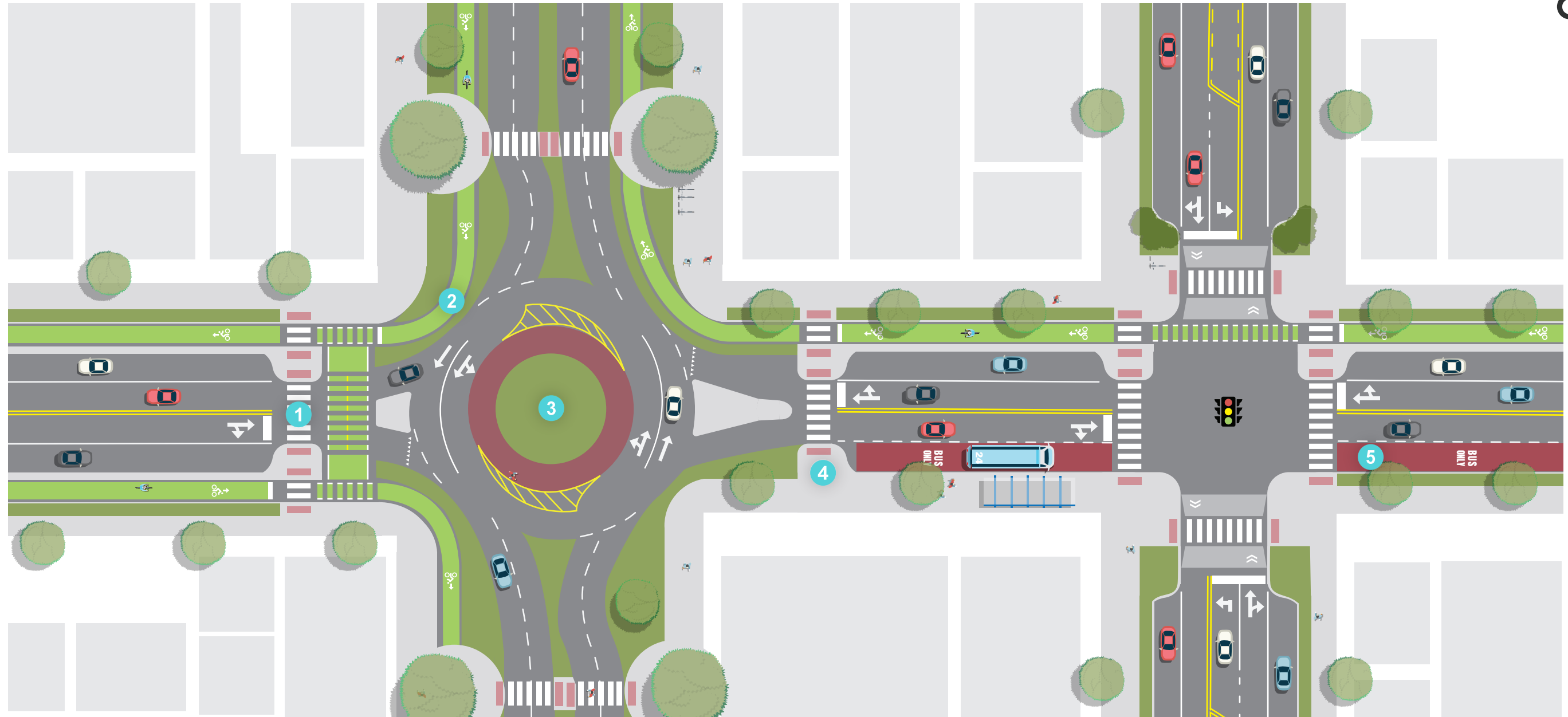

**1 HIGH VISIBILITY CROSSWALK**  
A crosswalk that provides increased visibility to motorists through high-visibility pavement markings, signing, and lighting.

**2 SEPARATED BICYCLE FACILITIES**  
Bike lanes that are physically divided from vehicle traffic, offering a safer and more comfortable experience for cyclists.

**3 ROUNDABOUT**  
Circular intersection that reduces vehicle speeds, improves traffic flow, and lowers the risk of serious right-angle collisions compared to traditional intersections.

**4 CURB EXTENSIONS**  
Curblines extended into the street, either with concrete or paint, at crossing locations to reduce the crossing distance for pedestrians, make pedestrians more visible to motorists, and provide space for street furniture, lighting fixtures, and traffic signal equipment.

**5 TRANSIT**  
Dedicated transit lanes that improve throughput of buses and reduce vehicle weaving on corridors. These lanes may sometimes be shared by bicyclists and/or right turn vehicles. Bus shelters are appropriate along transit lanes.

**Thoroughfare Cross Section Options**

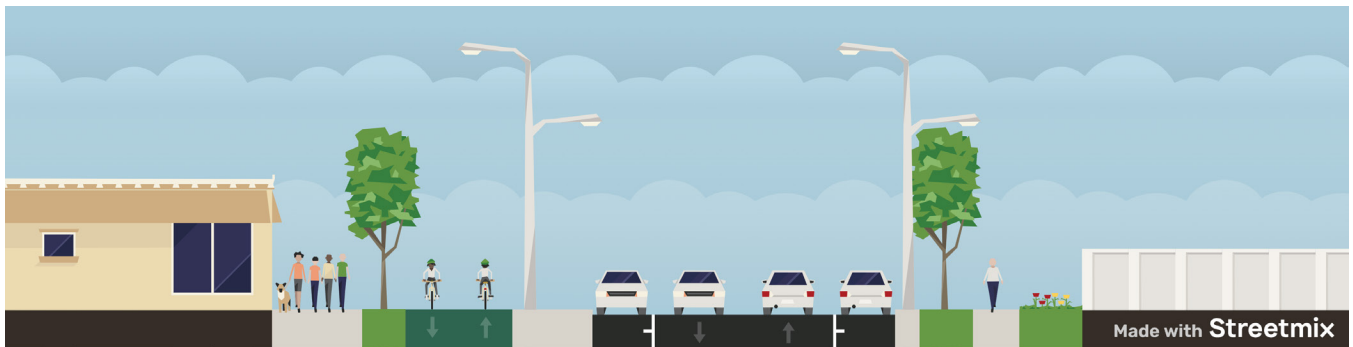

100-foot ROW: Two-way segment with parking lane on both sides and separated two-way mobility lanes

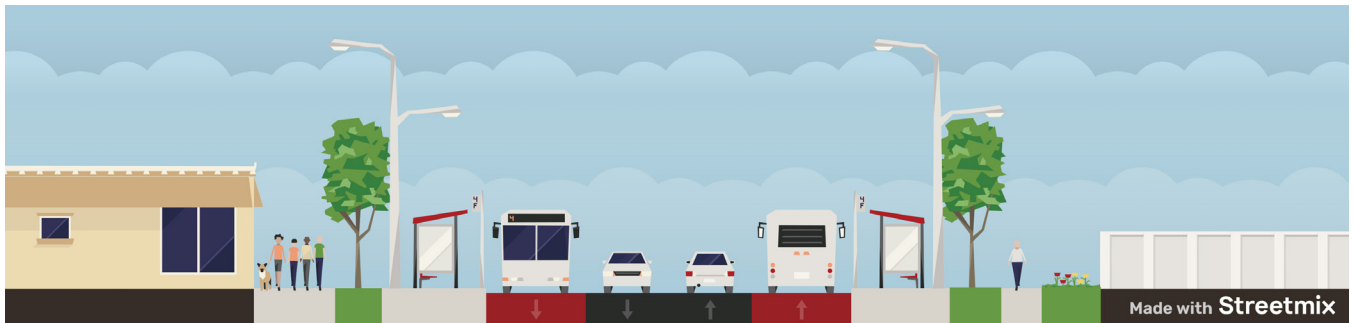

100-foot ROW: Two-way segment with transit-only lane on both sides

**Thoroughfare Cross Section Options**

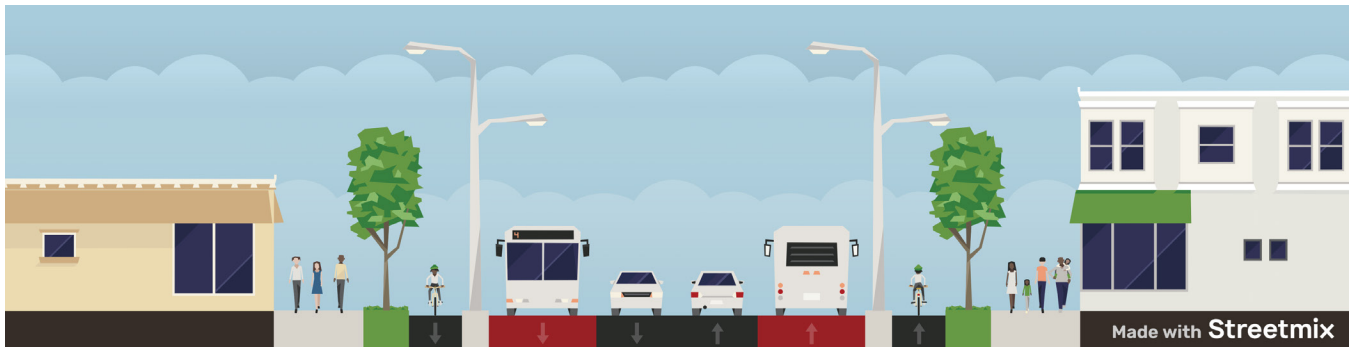

100-foot ROW: Two-way segment with transit-only lane on both sides and separated mobility lane on both sides

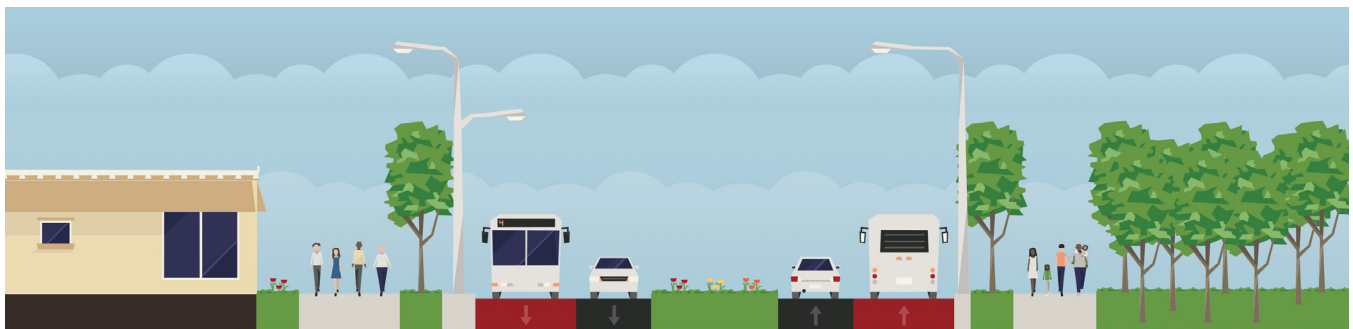

100-foot ROW: Two-way segment with wide median with transit-only lane on both sides

# Connector

Connectors are streets focused on access to individual lots and neighborhood streets. They serve destination trips and generally align with the definition of collectors.

## *Connector Example Streets*

- 22nd Street
- 59th Street
- 85th Street
- Holmes Road
- Rockhill Road
- Main Street south of the Plaza
- NW Waukomis Drive

### Connector Key Characteristics

	Typical	Rural Context
Target Speed	25 mph	35 mph
Design Vehicle	SU-30	Same
Control Vehicle	Standard Pump Fire Truck	Same
Right-of-Way Width	90'–100'	54'–90'
Lane Width	10' minimum; 11' when bus is present in that lane	10' minimum. 11' when trucks are present
Pedestrian Facilities	Pedestrian zone - 10' preferred, 6' minimum Amenity zone - 5-8'	Paved Shoulder
Curbside Uses	Landscaping, wayfinding, and transit stops	N/A
Micromobility Facilities	Traditional personal mobility lanes allowed under 20 mph / buffered lanes < 6,000 vpd / separated lanes ≥ 6,000 vpd	Paved Shoulder
Transit Facilities	Transit service is possible on Connector streets. Refer to "Accommodation for Transit Vehicles" under Design Guidance.	N/A
# of Travel Lanes	2 for streets < 20,000 vpd, otherwise 4	Same
Parking	No on-street parking	Same
Green Stormwater Infrastructure	Native plantings in buffer areas or medians and street trees placed behind the sidewalk	Ditch
Street Activation	Medium	Very Low
Place Type	Mixed Use Neighborhood, Mixed Use Residential, Residential High, Residential Medium, Residential Low, Conservation District (NC, N3, N2, N1)	Residential Agricultural
Access Control	Driveways should be managed for appropriate intersection distance and sight lines.	Same

# CONNECTOR

This conceptual roadway diagram illustrates a range of possible segments for the given street typology and is not intended to represent a continuous roadway condition.

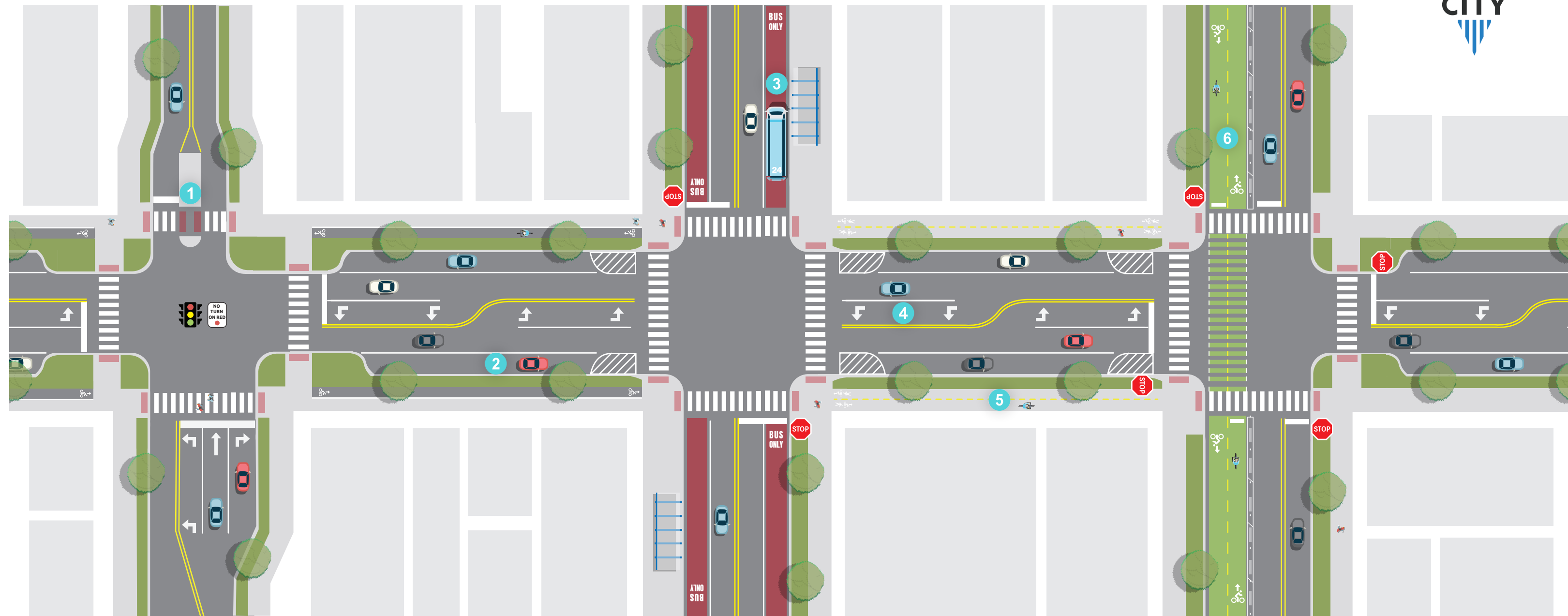

## 1 PEDESTRIAN REFUGE ISLAND

A median with a refuge area that provides pedestrians a protected area to cross a multilane road in two stages if necessary.

## 2 ON-STREET PARKING

Lane adjacent to traffic for parking that provides convenience access to nearby destinations, helps slow traffic, and serves as a buffer between motor vehicles and sidewalk users.

## 3 TRANSIT

Dedicated transit lanes that improve throughput of buses and reduce vehicle weaving on corridors. These lanes may sometimes be shared by bicyclists and/or right turn vehicles. Bus shelters are appropriate along transit lanes.

## 4 LEFT-TURN LANE

Dedicated lane on an intersection approach that separates left-turning vehicles from through traffic, which reduces left-turn crashes.

## 5 SHARED USE PATH

A wide path designed for pedestrians, cyclists, and other non-motorized travelers that promotes safe, active transportation away from traffic.

## 6 TWO-WAY CYCLE TRACK

Separated bike lanes that allow bicycle movements in both directions on one side of the street.

## Connector Cross Section Options



60-foot ROW: Two-way segment with separated mobility lane on both sides

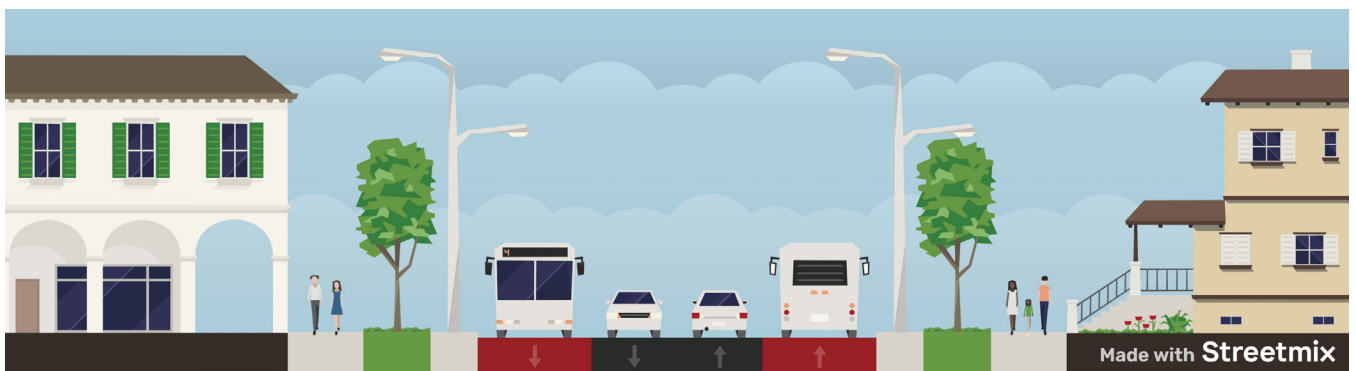

80-foot ROW: Two-way segment with dedicated transit-only lane on both sides



60-foot ROW: Two-way segment with parking lane on one side

# Neighborhood

Neighborhood streets are typically residential or local streets. They are lined with single family homes, low-density multifamily homes and corner stores. They have low traffic volumes and speeds, direct interaction with the roadway by users of all ages, and integrated mobility uses.

## *Neighborhood Example Streets*

- Almost all Terrace streets
- Charlotte Street
- Woodbridge Lane
- NW Oakcrest Drive
- N Strathberry Avenue

## Neighborhood Key Characteristics

	Typical	Rural Context
Target Speed	20 mph	25 mph
Design Vehicle	DL-23	Same
Control Vehicle	Standard Pump Fire Truck	Same
Right-of-Way Width	46'–54'	40'–60'
Pavement Width	28' minimum when parking is permitted; 22' minimum if no parking is permitted	Same
Pedestrian Facilities	5' minimum sidewalk on both sides of the street, or 8' minimum shared use path on one side of the street. If no sidewalks on a street are installed at the time of development, pedestrian facilities will not be provided by the City for a minimum of 50 years. The amenity zone should be 4-8.'	None
Curbside Uses	Landscaping	N/A
Micromobility Facilities	Personal mobility lanes on high usage mobility routes, sharrows, or none	None
Transit Facilities	Transit service is not likely on Neighborhood streets.	N/A
# of Travel Lanes	Travel lanes are typically not designated. Designers should limit travelway width where possible, especially if on-street parking is not provided.	Same
Parking	On-street parking where street width allows	Same
Green Stormwater Infrastructure	Landscaping and street trees	Ditch
Street Activation	High	Low

Some Neighborhood streets are “unimproved”—these are typically former rural roads which have been annexed into the City but still lack sidewalk or curb and gutter. These streets generally pose a very low safety risk. Unless they are fully reconstructed, it is not necessary that they be improved to the specifications of this typology.

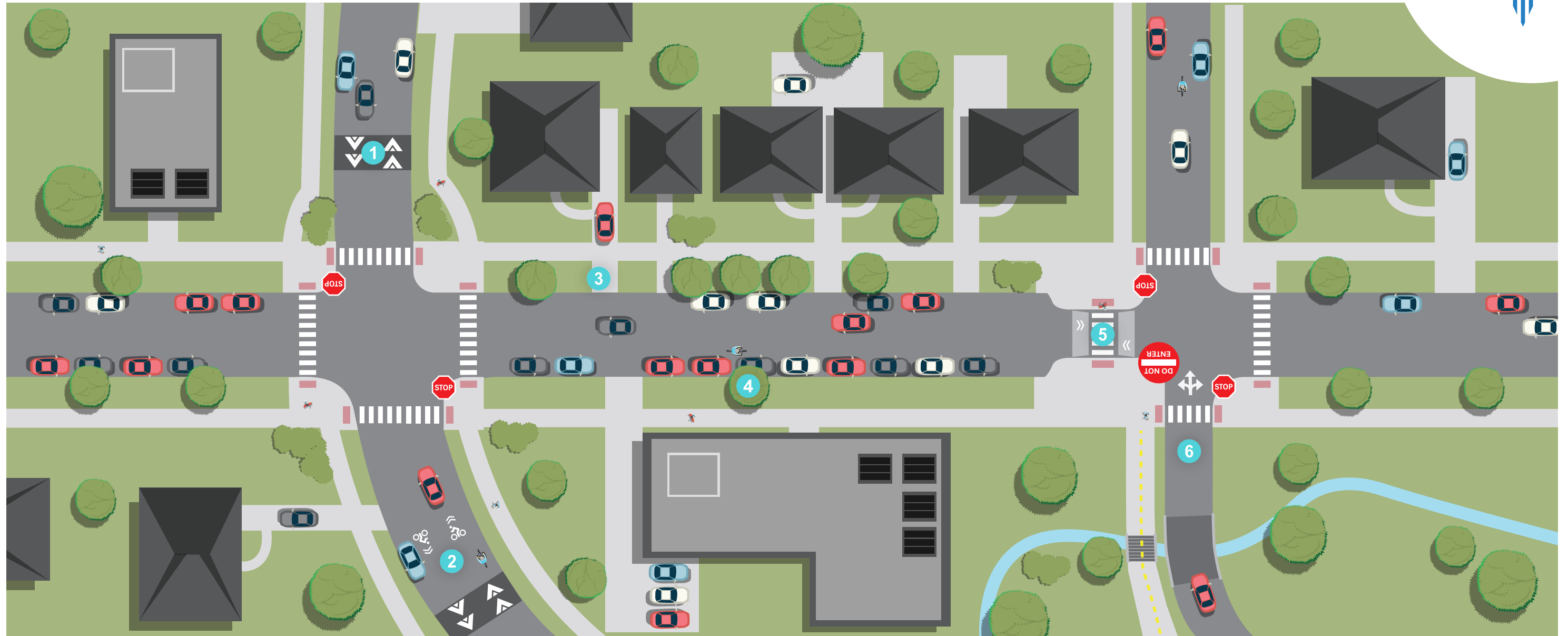

**1 SPEED HUMPS**  
Vertical deflection devices that slow vehicles, improving safety for pedestrians and cyclists.

**2 SHARROWS**  
Pavement markings on the roadway that indicate a shared lane for bicycles and vehicles, helping position cyclists safely within the lane and alerting drivers to their presence. This design element is only appropriate on streets that are low level of stress like neighborhood streets.

**3 ON-STREET PARKING**  
Parking spaces adjacent to travel lanes that provide a buffer between pedestrians and moving traffic and help to slow vehicles by visually narrowing the roadway.

**4 STREET TREES AND LANDSCAPING**  
Trees, shrubs and other landscaping elements adjacent to the roadway that enhance safety and walkability by calming traffic, providing shade, and improving neighborhood character.

**5 RAISED CROSSWALK**  
Crosswalks that are elevated (similar to a speed hump or table) that limit turning speeds of vehicles and increase the visibility of crossing pedestrians.

**6 NARROW STREETS**  
Streets with reduced width available for motor vehicle travel designed to slow vehicle speeds, enhancing safety for all users and creating a more livable, community-friendly environment.

**7 TRAFFIC CIRCLE (NOT PICTURED)**  
Circular intersections that slow vehicle speeds and reduce conflict points, improving safety and maintaining traffic flow at low-volume intersections.

**Neighborhood Cross Section Options**

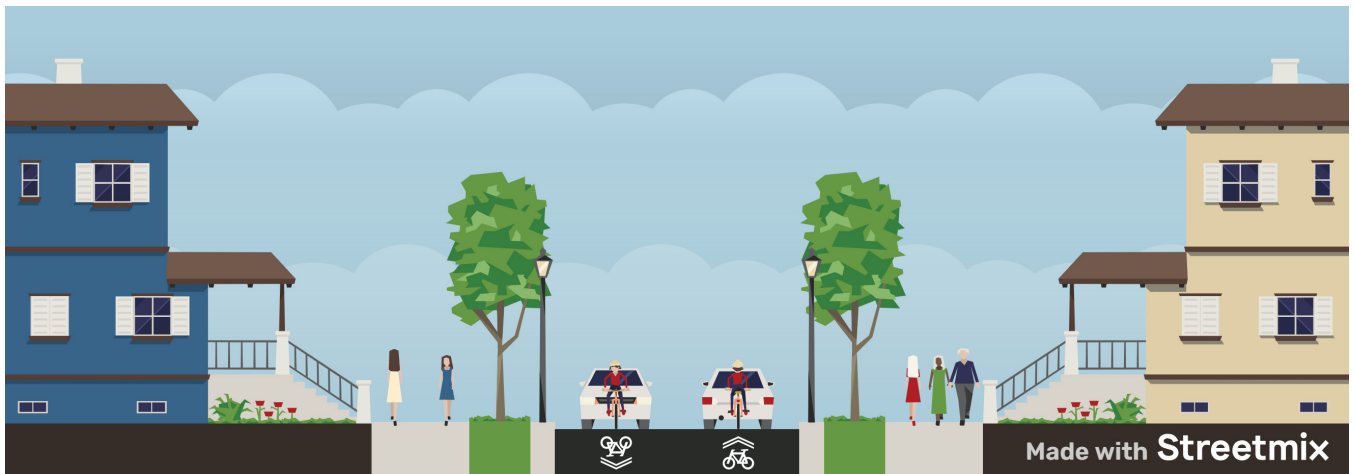

50-foot ROW: Two-way segment with shared lanes



50-foot ROW: Two-way segment with shared lanes and parking permitted on both sides

## Neighborhood Cross Section Options



50-foot ROW: Two-way segment with transit facilities on both sides



50-foot ROW: Two-way segment with parking permitted on both sides

**Rural Neighborhood Cross Section Options**

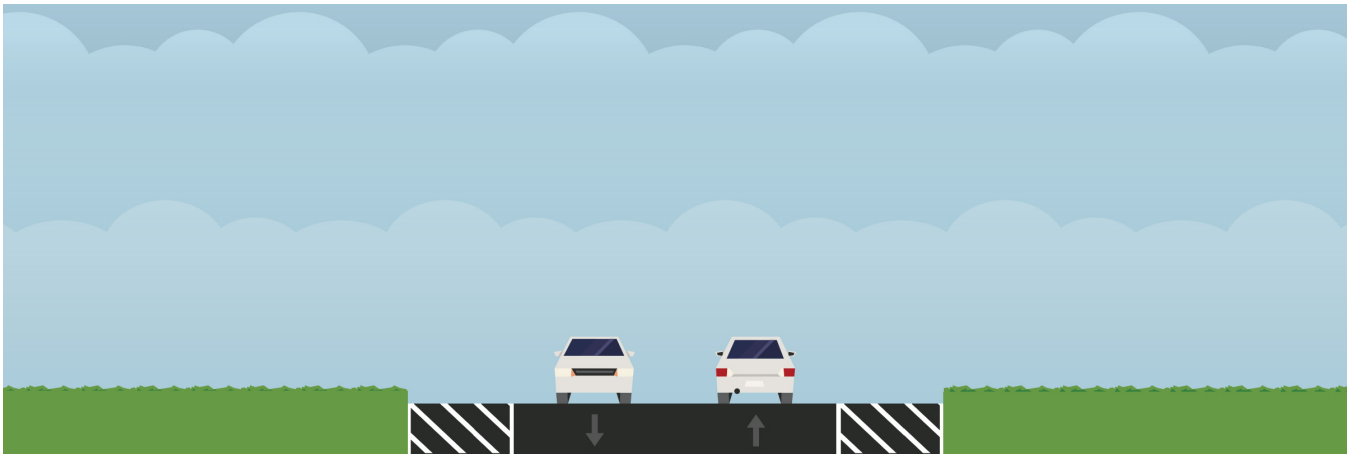

50-foot ROW: Two-way segment with paved shoulders on both sides



50-foot ROW: Two-way segment with paved shoulders on both sides

# Industrial / Business Park

Industrial / Business Park streets are in areas zoned as such with heavy traffic generators. These streets serve a high volume of heavy trucks and frequent turning maneuvers.

## *Industrial / Business Park Example Streets*

- Barry Road
- Front Street
- Manchester Trafficway
- Chouteau Trafficway
- N Kimball Drive
- N Topping Avenue
- Guinotte Avenue

**Industrial / Business Park Key Characteristics**

	Typical	Rural Context
Target Speed	25 mph	25–35 mph, depending on access density
Design Vehicle	WB-40	Same
Control Vehicle	Aerial Fire Truck MM100 / WB-62	Same
Right-of-Way Width	80'–100'	70'–90'
Lane Width	11'–12'	Same
Pedestrian Facilities	5'–10' sidewalk, 5'–8' buffer	Shared use path
Micromobility Facilities	Buffered or separated mobility lanes. Designers should provide the maximum possible buffer for personal mobility devices, such as bicycles.	Shared use path
Transit Facilities	Transit service is possible on Industrial / Business Park streets. Refer to "Accommodation for Transit Vehicles" under Design Guidance.	N/A
# of Travel Lanes	2 for streets < 20,000 vpd, otherwise 4	Same
Parking	No on-street parking	Same
Green Stormwater Infrastructure	Landscaping and ditch	Ditch
Curbside Uses	Landscaping	N/A
Street Activation	Low	Low
Place Type	Heavy Industrial, Light Industrial (ML, IF)	Same
Access Control	Driveways should be managed for appropriate intersection distance and sight lines. Access for major generators should be evaluated for appropriate traffic control treatments.	Same

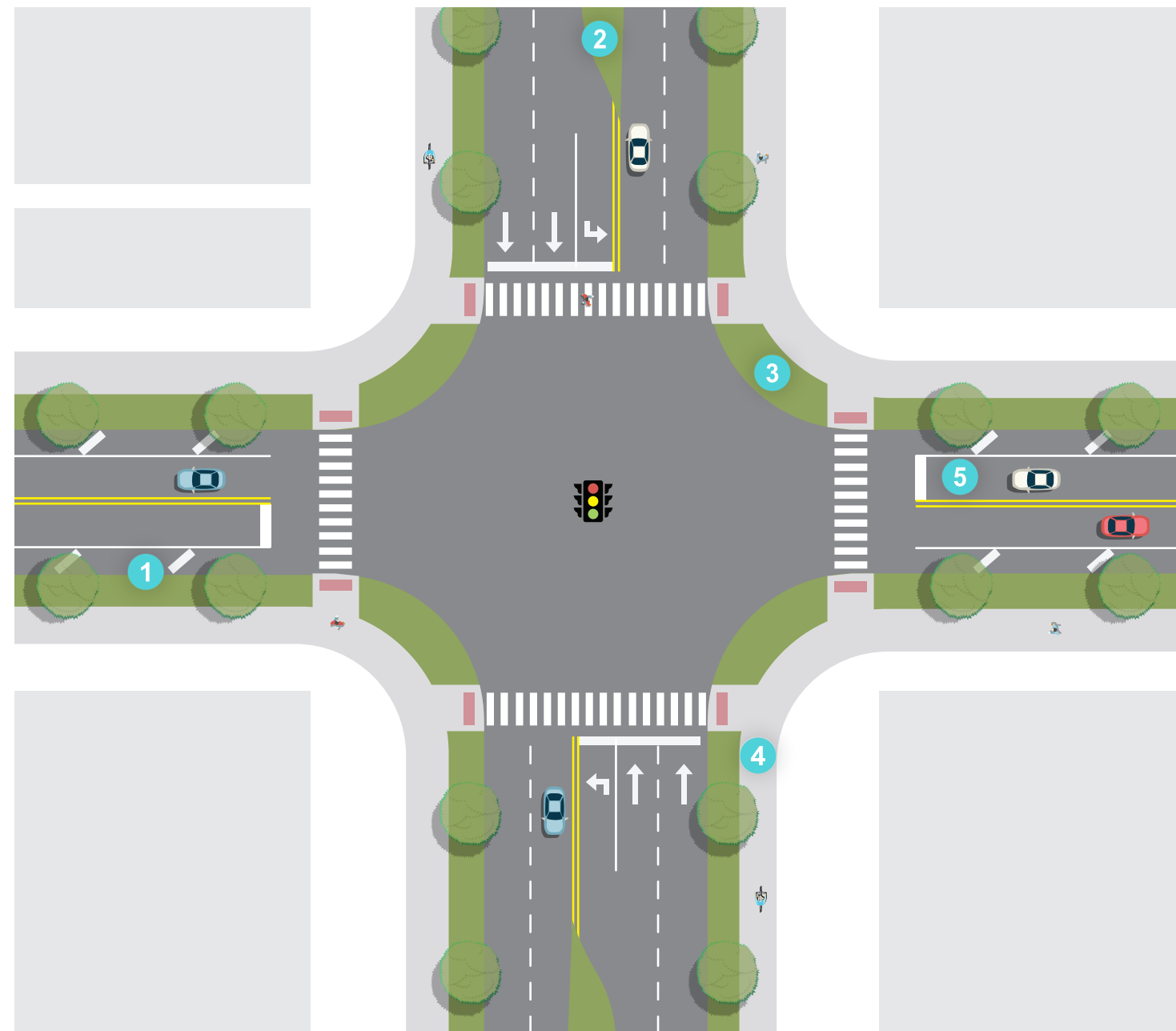

**1 WIDE BUFFER AREA**  
The shoulder and green space provide a wide buffer between heavy vehicles and pedestrians and cyclists.

**2 DIVIDED ROADWAY**  
Separating directions of travel with a median reduces the likelihood of head-on conflicts between larger, heavier vehicles.

**3 WIDER CORNER RADII**  
Industrial routes use wider corner radii to accommodate the turning movements of large trucks.

**4 SHARED USE PATH**  
A 10-ft paved travel way on both sides of the street provides a shared space for all non-motorized traffic.

**5 RECESSED STOP BARS**  
Stop bars are moved back from the intersection slightly to provide more comfort to crossing pedestrians and to allow a wider left-turn movement.

**Industrial / Business Park Cross Section Options**

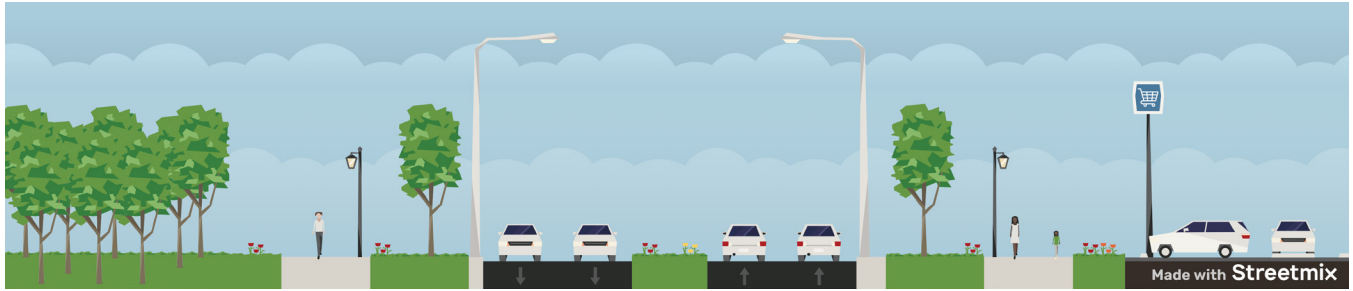

120-foot ROW: Two-way segment with median

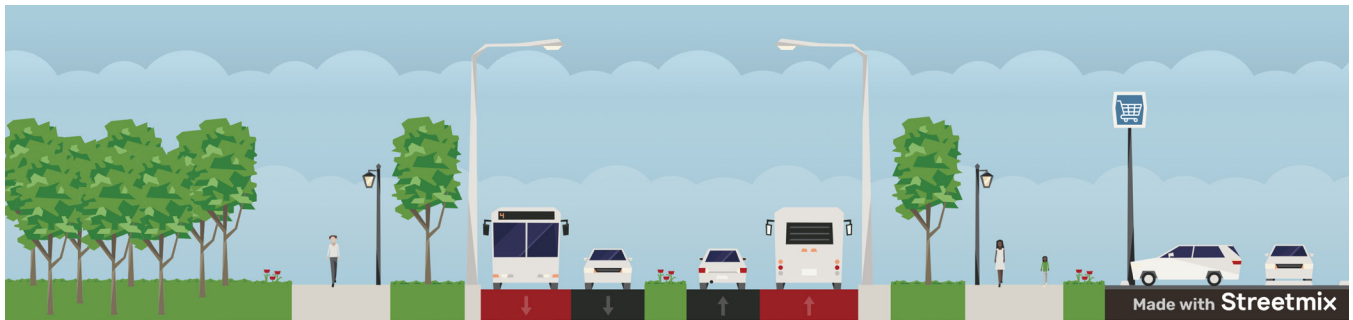

100-foot ROW: Two-way segment with median and transit-only lane on both sides



100-foot ROW: Two-way undivided segment

## Boulevards and Parkways

Kansas City's historic Boulevard and Parkway system was designed to preserve green space, connect City parks, and enhance urban life. These roads are managed by the Kansas City Parks and Recreation Department, who has published standards for their design with a focus on balancing the preservation of their historic significance with the vibrance of new development.

Generally speaking, boulevards are wide, formally landscaped streets that follow the gridiron street system, accommodate multiple points of ingress/egress and have intersections at all cross streets. Historically boulevards occurred within a hundred foot right-of-way with forty foot streets and thirty foot margins (tree lawn) for wide grass verges, sidewalks and triple rows of trees equally spaced. The original description of the margin was seventeen feet of turf with a double row of trees, an eight foot sidewalk, and then five feet of turf with a single row of trees to the property line. The double row of trees between the curb and the sidewalk allowed for the street to be widened, without removing all the trees, only the row closest to the curb. To this day the boulevards are some of the city's most pleasant corridors and resemble this original design while accommodating changing vehicular traffic. When developing new boulevards, the right-of-way shall be one hundred feet in width or more without a center median. The boulevard consists of a forty-four foot roadway, fifteen foot tree lawns and eight foot sidewalks. Symmetrical plantings of one or two rows of trees in the tree lawn shall be evenly spaced on both sides of the sidewalk.

In reference to the standards document adopted by the Parks and Recreation Department: It is by way of honoring the sense of "unity through . . . pervasiveness" that guides, in many respects, the formulation of these Boulevard and Parkway Design Standards. As stewards of the original Kessler Boulevards and Parkways System, it is an obligation of the Board of Parks and Recreation Commissioners and the city as a whole, to preserve the historic integrity of that system to the extent possible. Part of the responsibility rests in the assurance that the system itself will remain distinct and that travel on and proximity to a boulevard or parkway will convey its special status.

These standards can be found at [kcparks.org](http://kcparks.org).

This Streets Design Guide recognizes Boulevards and Parkways as separate street typologies but acknowledges that their function overlaps with other typologies presented in this document. In some places, they function as thoroughfares, in others as connectors, and are even found in the downtown core. In the Major Street Plan, there is a layer specifying which roadways are Parkways and Boulevards. These could be classified as arterial roads or collector roads, but are still maintained and owned by the Parks and Recreation Department.

As roadway, utilities, development, and other projects take place on or near Parkways and Boulevards, there may be an opportunity to include safety improvements aligned with Vision Zero principles. Users of this Guide are encouraged to refer to the Safety Principles discussion in Section 2 and the Design Guidance in Section 4 of this document to identify potential safety-focused improvements to the design of these facilities.

# Boulevards

Boulevards are wide, formally landscaped streets that follow the gridiron street system, accommodate multiple points of ingress/egress and have intersections at all cross streets. When developing new boulevards, the right-of-way shall be a minimum of 80 feet in width or more, subject to change with Park Board approval. The boulevard consists of 11-foot wide lanes, tree lawns and ten-foot sidewalks. Symmetrical plantings of one or two rows of trees in the tree lawn shall be evenly spaced on both sides of the sidewalk. Boulevards are more desired in commercial or high-density residential areas.

## Boulevard Cross Section Options

- 4-lane
- 4-lane with curbed mobility lane
- 2-lane
- 2-lane with parking
- 2-lane with median and curbed mobility lane
- 2-lane with curbed mobility lane

## ***Boulevard Example Streets***

- Armour Boulevard (Parking)
- Emanuel Cleaver II Boulevard (curbed mobility lane)
- The Paseo (median)
- Admiral Boulevard (2-lane)
- Red Bridge Road (4-lane with median)
- Englewood Road (2-lane with median and trail)

### ***Boulevards Key Characteristics***

Target Speed	30 mph
Design Vehicle	DL-23
Control Vehicle	Standard Pump Fire Truck
Lane Width	11' minimum
Pedestrian Space	For new construction or reconstruction projects, the sidewalk must be a minimum of 10' on both sides of the street meeting the Boulevard and Parkway Standards for sidewalks located in commercial areas.
Buffer Space	5'–15' of green space between road and sidewalk or path
Micromobility Facilities	Curbed mobility lanes, off-street trail separate from sidewalk.  Acceptable materials for separated mobility lanes include poured concrete curbing/median. The preferred mobility facility would be raised to sidewalk level and fully separate from vehicle lanes and sidewalk.  If a shared use path is selected, a minimum width of 12' shall be used.
Transit Facilities	Space should be provided for shelters and/or mobility hubs along continuous corridors that are current KCATA routes or may become one in the future. Approval from the Parks and Recreation Board of Commissioners is required for any installation of shelters or mobility hubs. Transit stops should focus on far side stops unless a key generator is located on the near side.
Freight	Design should not accommodate these vehicles as they are prohibited on parkways and boulevards.
Parking	Residential – Allowed on both sides – 8' in width  Non-Residential – Per approved plans – 8' in width
# of Travel Lanes	2 or 4
Green Stormwater Infrastructure	Native plantings and street trees as approved by the Parks and Recreation Department Development Review Committee and the Parks and Recreation Board of Commissioners.
Curbside Uses	Transit stops, on-street parking, shared mobility stations, bicycle parking
Street Activation	Medium/High
Place Type	All

\*see Parkway and Boulevard Standards for more detail at [kcparks.org](http://kcparks.org)

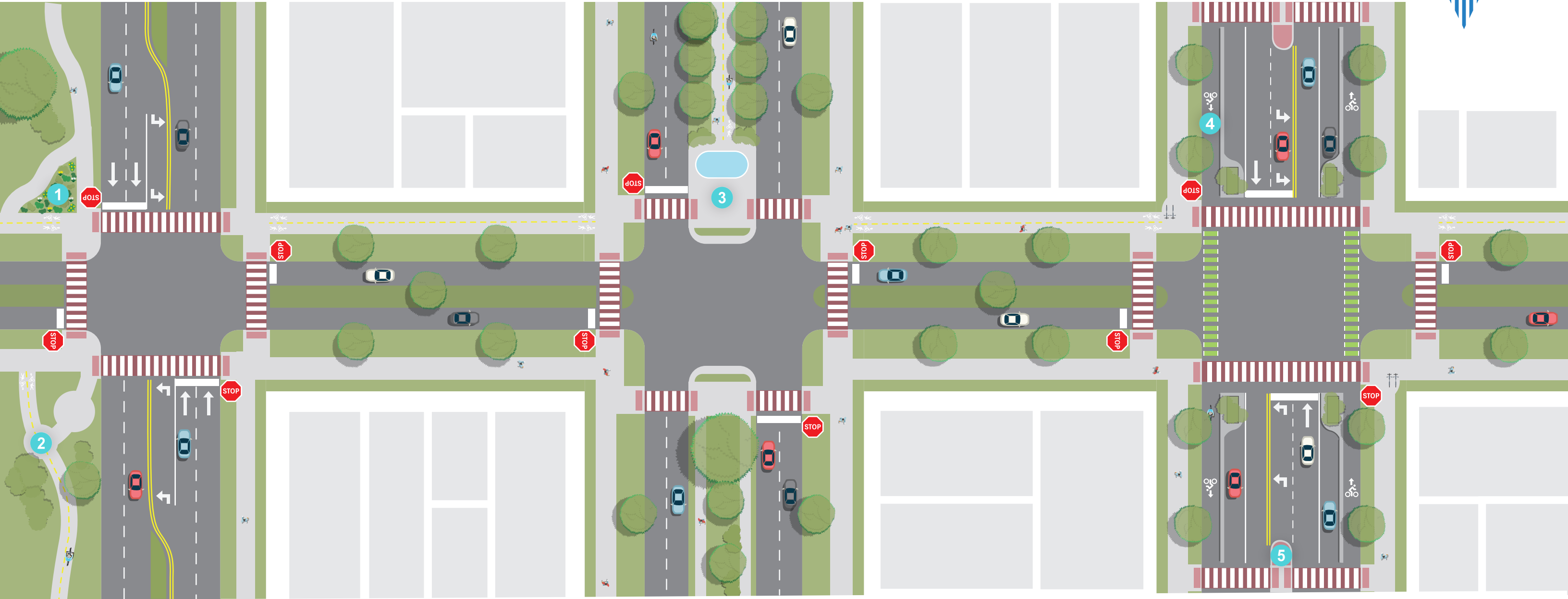

**1 RAIN GARDEN**  
A landscaped area that collects and filters stormwater runoff, helping reduce flooding and improve water quality.

**2 SHARED USE PATH**  
A wide path designed for pedestrians, cyclists, and other non-motorized travelers that promotes safe, active transportation away from traffic.

**3 ACTIVATED MEDIANS**  
Enhanced median spaces with landscaping or amenities that calm traffic and create more engaging, pedestrian-friendly streets.

**4 SEPARATED BICYCLE FACILITIES**  
Bike lanes that are physically divided from vehicle traffic, offering a safer and more comfortable experience for cyclists.

**5 PEDESTRIAN REFUGE ISLAND**  
A median with a refuge area that provides pedestrians a protected area to cross a multilane road in two stages if necessary.

***Boulevard Cross Section Options***



100-foot ROW: Two-way segment with center turn lane and separated mobility lane on both sides

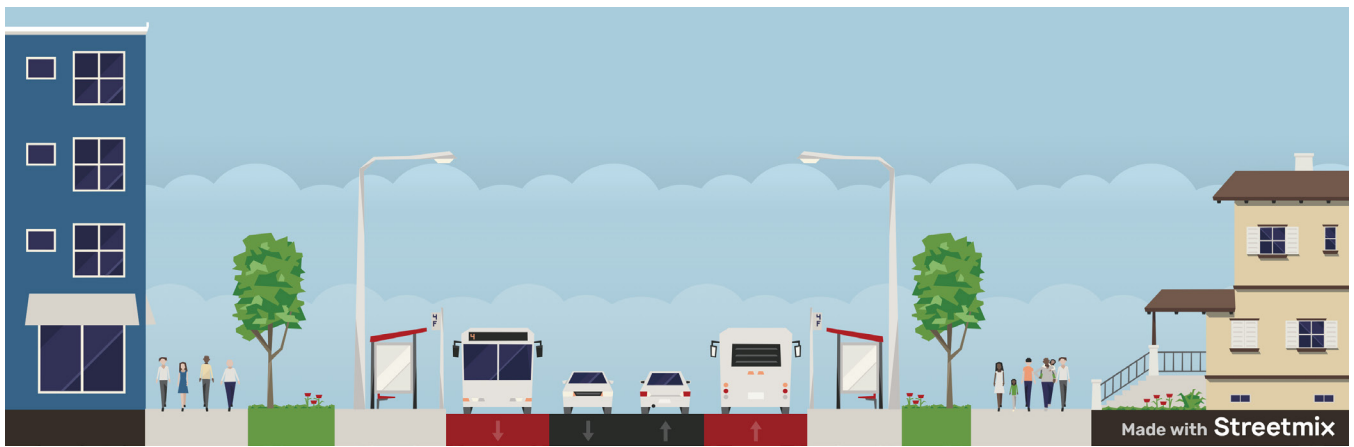

120-foot ROW: Two-way segment with transit-only lane on both sides

# Parkways

Parkways are less formal in alignment, following the natural terrain and retaining a pastoral quality even as they wind through developed areas. Parkways generally run north and south with wide medians and side panels. The right-of-way is a minimum of 150 feet, with a large median.

## Parkway Cross Section Options

- 4-lane
- 2-lane
- 2-lane with personal mobility lane
- 4-lane with personal mobility lane

## *Parkway Example Streets*

- NW Briarcliff Parkway (traffic circle with medians)
- Gillham Road (separated mobility lanes)
- Ward Parkway (activated median)
- Maple Woods Parkway (trail and sidewalks on both sides)

**Parkways Key Characteristics**

Target Speed	35 mph
Design Vehicle	DL-23
Control Vehicle	Standard Pump Fire Truck
Lane Width	11' minimum
Pedestrian Space	For new construction or reconstruction projects, the sidewalk must be a minimum of 10' on both sides of the street meeting the Boulevard and Parkway Standards for sidewalks located in commercial areas.
Buffer Space	Minimum 10' minimum
Micromobility Facilities	Curbed mobility lanes, off-street trail separate from sidewalk. Mobility (bicycle) amenities to be approved by the Parks Board.
Transit Facilities	Space should be provided for shelters and/or mobility hubs along continuous corridors that are current KCATA routes or may become one in the future. Approval from the Parks and Recreation Board of Commissioners is required for any installation of shelters or mobility hubs. Transit stops should focus on far side stops unless a key generator is located on the near side.
Freight	Design should not accommodate these vehicles as they are prohibited on parkways and boulevards.
Parking	On-street parallel parking may be allowed with approval from the Parks and Recreation Board of Commissioners.
# of Travel Lanes	2-4
Green Stormwater Infrastructure	Native plantings and street trees, as approved by the Parks and Recreation Department Development Review Committee and the Parks and Recreation Board of Commissioners. Trees may be clustered when used within a green stormwater infrastructure practice.
Curbside Uses	Transit stops, shared mobility stations, bicycle parking
Street Activation	Medium/High
Place Type	All

\*see Parkway and Boulevard Standards for more detail at [kcparks.org](http://kcparks.org)



**1 HIGH VISIBILITY CROSSWALK**  
A crosswalk that provides increased visibility to motorists through high-visibility pavement markings, signing, and lighting.

**2 TWO-WAY CYCLE TRACK**  
Separated bike lanes that allow bicycle movements in both directions on one side of the street.

**3 ROUNDABOUT**  
Circular intersection that reduces vehicle speeds, improves traffic flow, and lowers the risk of serious right-angle collisions compared to traditional intersections.

**4 SHARED USE PATH**  
A wide path designed for pedestrians, cyclists, and other non-motorized travelers that promotes safe, active transportation away from traffic.

**5 PEDESTRIAN REFUGE ISLAND**  
A median with a refuge area that provides pedestrians a protected area to cross a multilane road in two stages if necessary.

**6 SEPARATED MOBILITY LANE**  
A mobility lane at sidewalk level, separated from the sidewalk and roadway.

**Parkway Cross Section Options**



150-foot ROW: Two-way segment with wide median and two-way mobility lanes in the median



200-foot ROW: Two-way segment with wide median and park area between travel lanes and sidewalk

## **Trails**

Trails provide systems for non-motorized transportation and recreational opportunities for bicyclists, joggers and walkers. Trails shall be designed to meet the recommendations in the AASHTO Guide to the Development of Bicycle Facilities and the Trails KC Plan.

The trail shall be designed in a way that provides adequate access, is direct and convenient, shall blend with natural environment, and takes in consideration the topography of the land. The location of trails can vary from abandoned railroad corridors, rail-with-trails corridors, waterways, including levees, parks, greenways, stream corridors, stream buffers zones, utility corridors, parkways, street and highway corridors. All development within ¼ mile of a citywide trail alignment either constructed or planned shall be required to provide a connection to citywide trail. There are different trails to recognize:

Neighborhood Connector trails are public, non-motorized shared-use “local trail” that connects neighborhoods to the regional trails.

- Recommended width 8 feet. Any trails proposed that do not meet the standard width must be approved by Parks and Recreation Department Development Review Committee
- Smaller, shorter distance trails with neighborhood connectors, minimum 8 feet wide
- Examples:
  - Copperleaf subdivision (N Flintlock Road & NE 90th Street)

Regional trail is a public, non-motorized shared-use trail facility that serves as a primary or regional trail.

- Recommended minimum width 10 feet minimum with a maximum width of 12 feet
- Provides major connections throughout the city and to neighborhood communities
- Trail is longer trail with significant trail connectors
- Examples:
  - Line Creek Trail
  - Shoal Creek Trail
  - Blue River Trail
  - Trolley Track Trail

Trails adjacent to roadways are covered within the other street typologies. This section refers to trails that are not adjacent to roadways.

Minimum widths here mean that no utility poles, furnishings, equipment are within the trail width. Those items would be within a furnishing zone or buffer zone area.

On Boulevard	Trails not allowed
On Parkway	Encouraged as part of recreation facilities
Width of trail (parkway or regional trail)	10' minimum and 12' maximum
Width of trail (other trails)	8' minimum if space is not allowed for standard width. Required to get approval from Parks and Recreation Department Development Review Committee for other width desired
Width of trail (Gillham Road between Linwood Boulevard and Emanuel Cleaver II Boulevard)	8' wide located within the median (Hyde Park)



# Design Guidance

## Introduction

This section outlines the guidance to follow when designing City facilities in accordance with the City's [Complete Streets Policy \(Ordinance 170949, Chapter 64-41\)](#), [Vision Zero Action Plan \(kcmo.gov/visionzero\)](http://kcmo.gov/visionzero), [Standard Drawings](#), and national industry standards. This guidance is intended to reflect and implement safety for all modes of travel with an emphasis on pedestrian, bicycle, and transit accommodations.

This section informs the planning and design of all future street projects in Kansas City, including street reconstructions and street retrofit projects. The Street Design Guide also informs how the City will approach street projects led by partner agencies such as the Missouri Department of Transportation, the Mid-America Regional Council, local counties, or Kansas City Area Transportation Authority.

When managing a project on an individual street, designers are encouraged to use the interactive [Streets Design Guide Map \[include hyperlink when available\]](#) to find basic information about the street, including its street typology and place in the modal network. They can then use this guidance to supplement design information provided under "Typologies". Design criteria for specific projects will be established with a City project manager or representative. The "Implementation" section explains:

1. How and when to use the Streets Design Guide
2. When to vary from the Streets Design Guide
3. Key resources and partners for street design

Many design features can be implemented as "quick-build" projects (also known as tactical, temporary, or demonstration), which offer:

- Quick, low-cost installation (with a design lifetime of 1–5 years)
- An opportunity for the public to interact with and respond to improvements
- A chance to evaluate improvements before committing to long-term capital projects

The implementation of quick build projects may be initiated by public request, in response to safety issues, in coordination with redevelopment activities, or as part of the public involvement process for complex future street redesigns.

# Pedestrian Facilities

## Sidewalks and Shared Use Paths

### Sidewalk

Sidewalk is defined under Elements of Design. Design of sidewalks is regulated by the ADA with full details in the ADA PROWAG. Recommended sidewalk and buffer widths are specified in Typologies and may be wider than the general guidance provided below. Consideration may be given to not include sidewalks in areas where origins and destinations are not within feasible walking distance. In these cases, City project manager must agree to omit sidewalks. In these cases, it is intended to review the project’s Pedestrian Level of Stress based on the City’s Sidewalk Prioritization Plan to understand the importance of updates to these features to the area. For exceptions to be made, the City project manager must agree to omit sidewalks.

The minimum width of public sidewalks is stated within each street typology. The minimum width of public sidewalks abutting curb shall be six feet. All public sidewalks shall be a minimum of four inches thick. A sidewalk which is used for mixed traffic shall be six inches thick.

Sidewalks	
Min width utilizing buffer*	5'
Min width for pedestrian refuge	6'
Min width at back of curb	6'
Min running slope	1%
Max running slope (not a ramp)*	5%
Max cross slope	2%
ADA ramp max slope**	8.30%
Min turning space dimensions	4' x 4'

*\*for new construction, sidewalk should be 10' on both sides of the roadway (see Neighborhood typology for exception)*

*\*\*exceptions for sidewalk parallel to a roadway to run at the road grade that exceeds this value where appropriate*

*\*\*\*slope may exceed this value if ramp is >15' long*

### Shared Use Path

Shared use path is sidewalk 10 feet or greater in width. It is intended for use by pedestrians and micromobility devices. Paths must be wide enough to accommodate pedestrians and bicyclists traveling at variable speeds in both directions.

Shared Use Paths	
Min width	10'
Max cross slope	2%
Design Speed*	Refer to AASHTO Bike Guide design speeds
Clear zone width	3'
Unpaved shoulder width**	4'

\*used if path is not parallel to roadway within street R/W

\*\*2' can be used for trail/path width  $\geq 12'$

### Lighting

To illuminate the front of pedestrians and avoid silhouetting, lighting should be placed 10 feet in advance of intersection and midblock crossings on both approaches rather than directly above the crossing or behind it.

Specialty pedestrian lighting along sidewalks may be appropriate in commercial, urban and urban mixed use areas to enhance pedestrian comfort, security and safety, especially where street lighting and building lights do not adequately illuminate pedestrian areas. Consideration must be given to long-term costs and maintenance of these lights.

### Amenities

Any street amenities placed within the pedestrian space shall not impact the clear width of the sidewalk or provide any hazards for pedestrians.

### Cafes and Parklets

Sidewalk cafes and parklets should not inhibit ADA compliance—5 feet of clear sidewalk width is required. Cafes should place a retro-reflective strip placed adjacent to traffic and include a 1-foot buffer around the perimeter. They are not appropriate on streets with speeds greater than 30 mph.

### Parklets

Parklet	
Min Length for parallel parking	One Space (18'–20')
Min Length for angled parking	Three Spaces (27')
Min buffer between Parklet and adjacent parking	4'
Min. width	6'
Min. buffer between Parklet and traveled way	2'

## Sidewalk Cafes

Category	Element	Specification
Location & Siting	Minimum Lane Clearance	12' required unobstructed width of a travel lane next to a street café
	Corner Setback	20' from crosswalks
	Drainage Flow	6" minimum clearance from gutter/inlet flow lines
	Deck Gap	¼" spacing between planks for rainwater runoff
Platform/Deck	Surface Slope	≤ 2% cross slope; flush with adjacent sidewalk for ADA
	Load Capacity	≥ 100 psf live load (per IBC standards)
	Materials	Non-slip decking (wood, composite, steel, etc.)
	Fastening	Mechanically secured, no exposed bolts into pavement
Traffic Separation	Access Ramps	Required if platform is > ½" above sidewalk height
	Edge Protection	Barriers, planters, bollards at both ends of café zone
	Barrier Height	≥ 30" to provide deflection from vehicles
	Bollard Spacing	4' on-center, minimum 36" ADA gap
Visibility & Delineation	Crashworthiness	Use ASTM F3016-rated or equivalent for high-volume roads
	Reflective Strips	3" wide retroreflective tape on all barrier edges
	Signage	New Signage (to be adopted by City Council): "Café Zone Ahead", lane shift warnings
Pavement Markings	Lighting	Overhead Café lights or string lights
	Boundary Lines	White/yellow thermoplastic lines outlining café perimeter
Furniture & Fixtures	Table/Chair Clearance	Minimum 36" for ADA-compliant pathways
	Anchoring	Furniture must be anchored or weighted for wind > 30 mph
	Umbrella/Awning Height	≥ 7' clearance; must not obstruct driver or pedestrian sightlines
Drainage	Deck Gap	¼"–½" spacing between planks for rainwater runoff
Fire Hydrants & Utility Access	Access	At least 5' clearance on either side of the fire hydrant  Maintain 3' clearance on either side of utility boxes, manholes

## Roadway Artwork

“Roadway Artwork” is murals or art is painted onto the asphalt or concrete pavement. Artwork outside of the driving lanes and outside of crosswalks is allowed with approval from the Director of Public Works. Artwork within the driving area of the roadway is not permitted.

Intersection murals should not be used as a traffic calming measure, though they may have that result. They are most appropriate along low-volume streets in conjunction with other traffic calming methods with speeds below 20 mph. Murals are typically installed with acrylic traffic paint and should not encroach into crosswalk striping. Street surfaces should be thoroughly swept and power washed before artwork is applied.

## Micromobility Facilities

Preferred materials for separated mobility lanes include poured concrete curbing/median. Delineators or other temporary materials are acceptable as an alternative. The City shall approve of any materials used for personal mobility facilities.

Applicability of Personal Mobility Facilities		
Personal Mobility Facility Type	Vehicle Speed (mph)	Volume (vpd)
Separated mobility lane	Any	Any
Buffered mobility lane	≤ 25	≤ 6,000
Traditional mobility lane	≤ 20	≤ 3,000
Bicycle boulevard	≤ 15	≤ 2,000

### Separated Mobility Lanes (Major Separation)

Separated mobility lanes utilize a physical barrier from vehicular traffic.

### Protected Mobility Lanes

Buffered Mobility Lanes	
Preferred width	5'
Min width	4'
Min horizontal separation from vehicular traffic	3'
Delineator spacing	8'–20'

\*Horizontal separation from vehicular traffic can be reduced in constrained conditions



Figure 3 – Two-way cycle track using quick-build materials

### Cycle Tracks

Cycle tracks are two-way protected mobility facilities. These include a vertical separation barrier in the buffer space.

Cycle Track	
Preferred width	12'
Min width	8'
Min buffer from vehicular traffic	3'

### Shared Use Paths

Shared use paths move bicycles to sidewalk level and are considered separated mobility lanes. See "Shared Use Path" under "Pedestrian Facilities".

### Personal Mobility Lanes (Minor Separation)

Other personal mobility facilities are typically one-directional painted lanes parallel to the roadway.

### Buffered Mobility Lanes

Buffered mobility lanes include horizontal buffer without a physical barrier.

Buffered Bike Lanes	
Preferred width	5'
Min width	4'
Min horizontal separation from vehicular traffic	3'

### **Traditional Mobility Lanes**

Traditional mobility lanes are directly adjacent to vehicle traffic.

<b>Conventional Mobility Lanes</b>	
Preferred width	5'
Min width	4'

### **Bicycle Boulevards**

#### ***Use of Bicycle Boulevards***

Bicycle boulevards combine bicycle and vehicle traffic in shared lanes. Implementing a bicycle boulevard typically involves signage and “sharrow” pavement markings. Bicycle boulevards are only suitable for low-speed, low-volume streets. They should be implemented in combination with traffic calming measures where feasible.

#### ***Signage***

Designers should refer to the MUTCD for full guidance on personal mobility (bicycle) signage. On bicycle boulevards, Bikes May Use Full Lane (R4-11) signs are preferred to Share the Road (W16-1) signs, which may force cyclists into the gutter pan or dooring zone.

## **Transit and Freight Traveled Ways**

### **Accommodation for Transit Vehicles**

Accommodation for transit stops is dependent on the level of transit service, which is determined by the KCATA. This guidance is intended to aid designers in allocating space. Where possible, designers should seek to co-locate transit stops with shared mobility devices (bike share) and other amenities to create “mobility hubs”. Designers should also consider a BU-40 design vehicle on streets with heavy transit traffic.

#### ***Designated Transit Lanes***

Dedicated transit lanes can improve the reliability of transit service and are appropriate when headways are 8 minutes or less (often designated as BRT service). This can include:

- Curbside transit lanes, which prohibit parking but may allow vehicles for right-turn movements at intersections.
- Center transit lanes, which can be combined with left-turn restrictions to remove driveway conflicts. These lanes use center stations and typically require less right-of-way.
- Peak-only transit lanes, which accommodate shorter headways during peak periods. During off-peak times, these lanes can be used for parking or loading.
- Contraflow transit lanes, applicable on one-way streets.

Especially where transit streets intersect, the urban form may be characterized by Transit-Oriented-Development (TOD). Street designers should refer to [Kansas City’s TOD Policy](#) for more information on these areas.

### **Bus Stops**

<b>Accessible Passenger Loading Zones</b>	
Minimum dimensions	8' x 8'

### **Streetcar Stops**

Any facilities designed on streets that also contain KC Streetcar features shall require coordination with the KC Streetcar.

<b>KC Streetcar</b>	
Min. length of stop platform	27'
Min. width of stop platform for side stops	8'
Min. width of stop platform for one-sided median stops	10'
Min. width of stop platform for dual-sided median stops	12'
Height of platform above rail	14'

### **Accommodation for Freight Vehicles**

#### **Unloading Areas**

At off-peak times, travel lanes, bus lanes, or on-street parking can be used as unloading space for freight vehicles. Designers should seek to prevent freight vehicles from parking in personal mobility lanes or at street corners, where they may obstruct visibility.

#### **Corner Aprons**

As discussed in Safety Concepts, curb radii should be limited to the practical minimum. In areas with heavy freight traffic, corner aprons can slow passenger vehicles while allowing large vehicles to mount the curb. Alternatively, large trucks can be encouraged to reach their destinations using left-hand turns.



Figure 4 – Corner apron

### ***Recessed Stop Bar***

For large vehicle movements that will encroach on an opposing travel lane, the stop bar should be set back from the intersection. If on-street parking is present, it should also be set back. If either approach is uncontrolled, designers should consider implications for sight distance.



*Figure 5 – Recessed stop bar*

## Vehicular Traveled Ways

Please refer to the Street Typologies section for guidance on the following elements of design:

- Design Speed
- Design Vehicle
- Lane Count

### Cross Section

#### ***Pavement and Curb***

Lane widths should generally be 11 feet. Designers should be using the minimum total pavement width. In rural areas, shoulders should be 6–10 feet. Roadways utilizing curbs should follow the curb dimensions set forth in the [City's Standard Drawings](#).

#### ***Clear Zone***

Clear zone is the unobstructed and traversable roadside area that allows a driver to stop safely or regain control of a vehicle that has left the roadway. For roadway sections with shoulders, the width of the clear zone is determined by several factors that include traffic volumes, speeds, and slopes. Clear zone area begins at the edge of the roadway and includes any shoulders present on the road. Clear roadsides consider both fixed objects and terrain that may cause vehicles to roll over. For roadway sections with curb and gutter, 2.5 feet is recommended behind the face of the curb.

Clear Zone Slopes	Max Slope
Foreslope	3:1*
Backslope	4:1

*\*4:1 preferable*

*\*\*Slopes can be exceeded where protected or beyond clear zone*

#### ***Guardrail and Barrier***

Guardrails and barriers are used on the roadside to protect drivers from roadside hazards within the clear zone. It is generally preferred to remove hazards from the clear zone instead of using a guardrail or barrier.

### Horizontal Alignment

#### ***Pavement Cross Slope***

Roadway	Cross Slope
All roadways $\leq$ 3 lanes in each direction	2%

### Horizontal Curves and Superelevation

Superelevation will be very rare on City streets. Generally, the need to superelevate a roadway is dependent on speed, the radius of the horizontal curve, and the surrounding environment. Designers should consider opportunities to reduce vehicle speeds before opting to superelevate the roadway on a curve. Designers should refer to the following sections of the AASHTO Green Book for curve design:

Urban Context	Resource
Low speed urban areas	AASHTO Green Book Table 3-13: Minimum Radii and Superelevation for Low-Speed Streets in Urban Areas
All other areas	AASHTO Green Book Table 3-10: Minimum Radii for Design Superelevation Rates, Design Speeds, and $e_{max} = 4\%$

### Horizontal Sight Distance

As discussed in "Safety Concepts", clear sight lines are critical to street safety. Refer to the following to determine sight distance on horizontal curves:

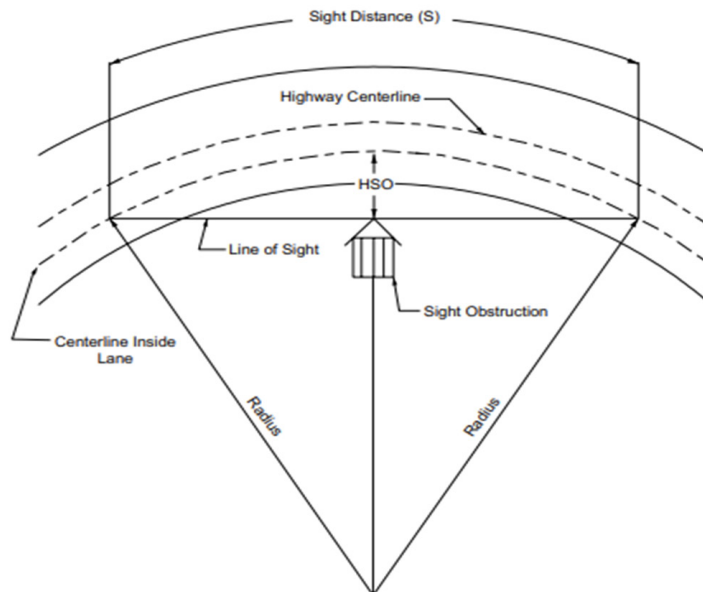

Figure 3-13. Diagram Illustrating Components for Determining Horizontal Sight Distance

U.S. Customary
$HSO = R \left[ 1 - \cos \left( \frac{28.65S}{R} \right) \right]$
where: $HSO$ = Horizontal sight line offset, ft $S$ = Sight distance, ft $R$ = Radius of curve, ft

Figure 6 – Horizontal Sight Distance on a Curve (AASHTO A Policy on the Geometric Design of Highways and Streets)

## Vertical Alignment

### Crest and Sag Vertical Curves and Stopping Sight Distance

Design Speed	Min Stopping Sight Distance	Crest Vertical Curve K Value	Sag Vertical Curve K Value*
15 mph	80'	3	10
20 mph	115'	7	17
25 mph	155'	12	26
30 mph	200'	19	37
35 mph	250'	29	49

\*K values can be lessened to half their reported value under lit conditions

Source: AASHTO Green Book

### Vertical Clearance

Facility under bridge	VC
Interstate or principal arterial routes	16.5'
State routes with volumes $\geq$ 1700 vpd	16.5'
State routes with volumes < 1700 vpd	15.5'
Other streets*	14.5'
Railroads**	23'
Pedestrian facilities***	8'
KC Streetcar facilities	19'

\*use 15.5' over roadway in commercial zones

\*\*up to 23.5' required for BNSF/UPRR lines

\*\*\*7' clearance is allowable if 8' is not feasible

Source: MoDOT Engineering Policy Guide

### Vertical Grades

Typology	Min Grade	Max Grade	Absolute Max Grade
Neighborhood streets		10%	13%
Connector streets	1%*	8%	10%
All other streets		6%	

\*Absolute minimum grade in uplands is 0.8% and 0.5% in river bottoms if concrete pavement used and engineer can show drainage is adequately collected

Source: KCMO 5200

## Vehicle Parking

On-street parking can serve as a traffic-calming measure and provide convenient access to land uses. Parking should be set back at least 20 feet longitudinally from intersections and crossings to allow for clear sight lines.

**Parallel Parking**

Parallel Parking	
Min width of parking spaces	8'
Min length (end space)	20'
Length (regular space)	22'–26'

**Angled and Reverse-Angled Parking**

Reverse-angled parking is generally preferred to angle parking, especially:

1. On one-way streets
2. If a personal mobility facility separates travel lanes from parking lanes

Reverse-angled parking should be 45°—refer to City Standards. See Municode section 70-525 for designation of streets for angle parking.

Parking Angle (degrees)	Stall Width	Stall Depth	Stall Length	Distance between stall and adjacent traffic lane
45	8.5'	18.7'	18'	3.5'
60	8.5'	19.8'	18'	3.5'

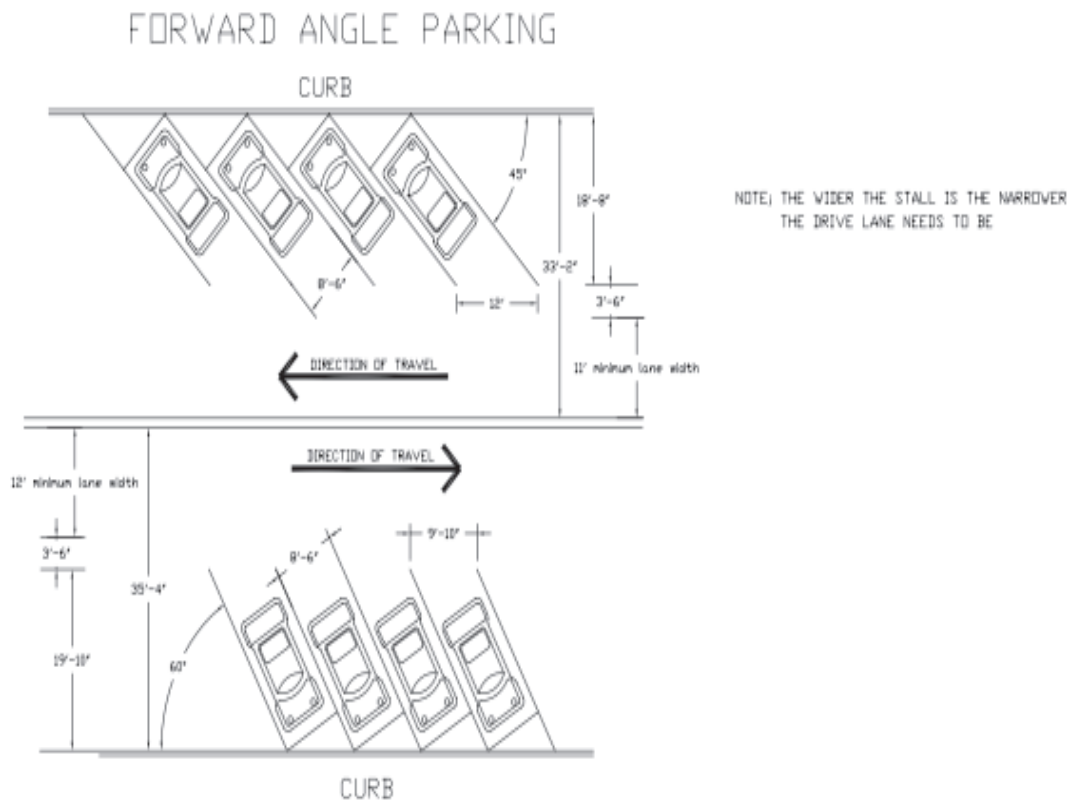

Figure 7 – Example of 45° and 60° Angle Parking Pavement Marking Layout (KCMO Traffic Engineering and Operations Manual)

**Parking Meters/Kiosks**

Parking meters and parking pay stations that serve accessible parking spaces should comply with ADA PROWAG requirements. A clear space must be located such that, at no more than 40 inches above the center of the clear space, any display or information on parking meters is visible.

**ADA On-Street Parking**

The appropriate amount of ADA-designated parking is defined in the ADA PROWAG:

Total Number of Metered or Designated Parking Spaces	Minimum Required Number of Accessible Parking Spaces
1 to 25	1
26 to 50	2
51 to 75	3
76 to 100	4
101 to 150	5
151 to 200	6
201 and over	4 percent of total

Figure 8 – Required Number of ADA On-Street Parking Spaces (ADA PROWAG)

**Traffic Calming**

**Road Diets**

“Road Diets” are a Proven Safety Countermeasure that typically convert four travel lanes into two travel lanes with a two-way left-turn lane. The extra right-of-way can be converted into buffer or space for other modes. Road diets are not recommended for facilities which carry more than 25,000 vehicles per day. Refer to the TEOM for guidance on the evaluation of streets for road diets.

**Speed Cushions, Bumps & Humps**

Speed cushions, bumps, and humps reduce speeds by vertically deflecting vehicles. They should generally be limited to low-speed streets with curb and are not suitable for collectors with a double-yellow centerline. Designers should ensure that drainage functions are not compromised by speed cushions, bumps, or humps.

Speed Cushions, Bumps & Humps	
Height	3"
Preferred deflector spacing	250'–600'
Min. distance from unsignalized intersections	125'
Min. distance from driveways	15'
Max. recommended volume	1,500 vpd
Max. street grade	8%

### Curb Extensions

Curb extensions—which can be applied at midblock or as corner bulb-outs at intersections—slow vehicles, shorten crossing distance, and make pedestrians more visible.

Curb Extensions	
Min. separation from travel lane	1.5'
Approach/exit angle to curb extension in areas with snow for plows	45°
Min. length in approach direction	20'
Min. length in exit direction	5'
Max. mountable barrier element spacing	10'
Min. width	2'
Min. space between curbs	20'
Typical width*	8'
Max. curb radius	15'
Min. curb radius	10'

*\*shall not be greater than 1' less than the width of adjacent parking stalls*

Intersection daylighting treatments, primarily intended to improve sight distance, are similar to curb extensions. These can be painted (double solid lines) or built in concrete. If delineators are used to prevent parking at intersection corners, they should allow for turning movements with a 30-foot inside radius and 50-foot outside radius.

TYPICAL DETAIL  
INTERSECTION DAYLIGHTING

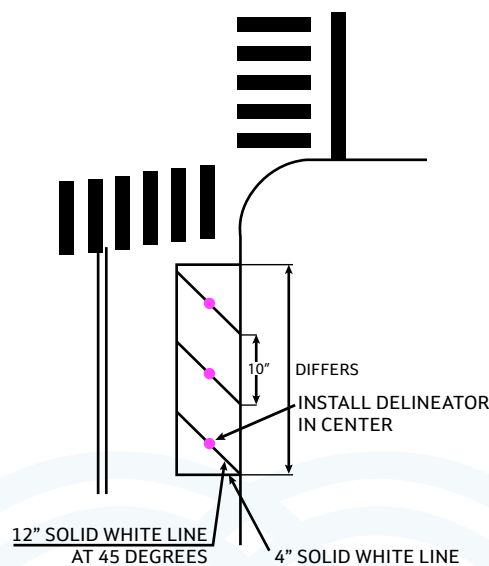

### **Chicanes**

Chicanes reduce vehicle speeds and focus driver attention by disrupting an otherwise straight roadway. They may be achieved with curb extensions, pavement markings and delineators, temporary curbs, or planters. The max return angle for Chicanes should be 45°.

### **Traffic Circles**

Traffic circles or “mini roundabouts” reduce vehicle speeds by forcing all approaches to slow at minor intersections.

<b>Traffic Circle (Permanent)</b>	
Inscribed circle diameter	45'–90'
Central island requirements	Fully Traversable

Traffic Circles can also be accomplished with temporary materials. For these, center islands should be demarcated with a 4-inch retroreflective yellow stripe.

<b>Traffic Circle (Temporary)</b>	
Min. clear distance between curb and center island feature	15'
Center island recommended diameter	10'

# Intersections and Crossings

## Intersection Configuration

### Intersection Sight Distance

Proper intersection sight distance should be provided at unsignalized intersections as defined by AASHTO's A Policy on the Geometric Design of Highways and Streets, Chapter 9.

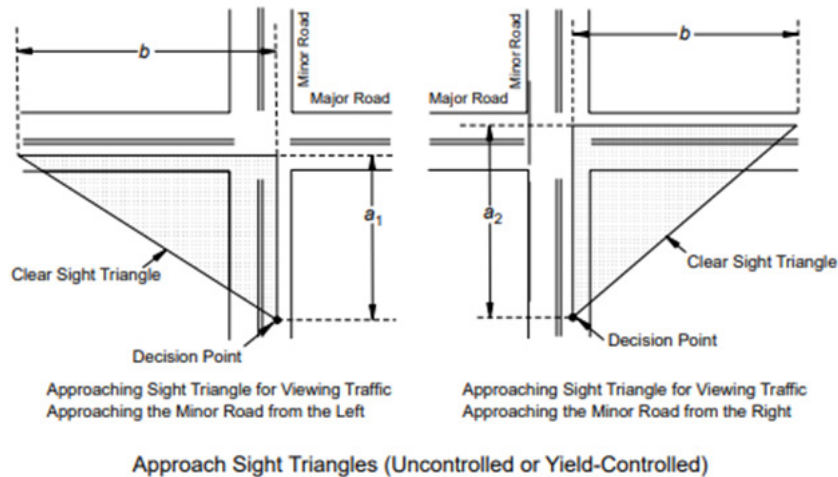

Figure 9-16—Approach Sight Triangles at Intersections

Figure 9 – Intersection Sight Distance (AASHTO A Policy on the Geometric Design of Highways and Streets)

### Intersection Angle

Intersection Angle	
Preferred angle	90°
Minimum angle for skewed intersection*	75°

\*skewed intersections should be avoided if possible

### Implications for Pedestrians and Cyclists

Vehicle speed at an intersection significantly impacts vulnerable road user safety. As stated in "Geometry" under "Safety Concepts", designers should seek to minimize curb radii to achieve lower turning speeds.

Similarly, the layout of an intersection will impact vulnerable users. While turn lanes have several safety and operational benefits, they also increase crossing distance. To the extent possible, designers should minimize intersection size and complexity. Right-turn "slip lanes" allow high-speed turns and should not be used.

## Pedestrian Crossings

### Crosswalks

Kansas City uses continental and parallel line style crosswalk markings. All crosswalks must be a minimum of 6 feet wide with the stop bar at least 4 feet from the crossing. Crosswalks should be wider in areas with higher volumes of pedestrian traffic.

### Midblock Pedestrian Crossings

Warning signage and marked crosswalks are necessary for any midblock pedestrian crossing. Where possible, solar power should be used for crossing devices.

Applicability of Midblock Crossings			
Device	Lane Count	Vehicle Speed	Volume
Rectangular Rapid Flashing Beacon	$\leq 2$	$\leq 40$ mph	$\leq 15,000$
Pedestrian Hybrid Beacon	$\geq 3$	Any	$\geq 9,000$

### Curb Ramps

Individual concrete curb ramps should be designed for each direction of pedestrian travel that crosses another street. Ramps that appear to combine 2 directions of pedestrian travel with a diagonal configuration should be avoided if at all possible since those ramps effectively and errantly direct the visually impaired pedestrians into the center of the intersection. Design of sidewalk curb ramps is regulated by the ADA with full details in the ADA PROWAG.

## Personal Mobility (Bicycle) Crossings

### Personal Mobility Accommodation at Intersections

At intersections, personal mobility paths should remain to the right or left of vehicular lanes. Designers should avoid designs which mix cars and personal mobility devices at intersections or place personal mobility devices between vehicular lanes. Designers should not “drop” personal mobility lanes on the intersection approach. Compared to midblock sections of the travelway, equal or greater separation for personal mobility devices is necessary at intersections. If vehicles must merge with personal mobility space, ensure that cyclists have clear right-of-way.

In general, designers should maximize the visibility of bicycles at intersections. They can accomplish this with:

- Two-stage turning areas
- Bike boxes or forward queuing areas (minimum 10 feet deep)
- Larger “visibility zones”: where a driver can see the personal mobility path without obstructions (such as on-street parking)

### ***Pavement Markings***

Personal mobility paths should be marked through the intersection.

<b>Cross Street:</b>	<b>Primary Street:</b>					
	<b>Arterial</b>	<b>Collector</b>	<b>Major Driveway</b>	<b>Minor Driveway</b>	<b>Local &gt; 40'</b>	<b>Local ≤ 40'</b>
Arterial	Green	Green	Green	Chevron	Chevron	None
Collector	Green	Chevron	Chevron	None	None	None
Local > 40'	Green	Dashes	None	None	None	None
Local ≤ 40'	Green	Dashes	None	None	None	None

In general, green markings should be used where bicycles mix with a high volume of vehicles. Personal mobility lanes and cycle tracks, along arterials, should include green paint in shared right turn lanes and mixing zones approaching the intersection. Chevrons or sharrows are suitable for these applications on collector streets. Shared use paths should follow the recommendations for pedestrian crossings.

### ***Track Crossings***

Streetcar rails can be a hazard for bicycle tires. Personal mobility paths should be positioned to meet the track at a 60–90-degree angle. Warning signage for bicycles in advance of track crossings may also be appropriate.

### ***Traffic Signals***

In general, shorter signal cycles benefit pedestrians and cyclists by creating frequent crossing opportunities, especially when pedestrian signals are actuated. Designers should minimize the number of phases and total cycle lengths where possible.

Pedestrian recall and extended walk are encouraged, especially in areas of higher pedestrian activity. Kansas City’s Traffic Engineering and Operations Manual has more guidance on these timing elements.

### ***Pedestrian Leading Interval***

<b>Leading Pedestrian Interval</b>	
Recommended interval before vehicle green	3–7 s

### ***No Turn on Red (NTOR)***

When turning right at red lights, drivers are likely to focus on oncoming traffic instead of hazards where they seek to turn. Prohibiting this behavior improves pedestrian safety in the crosswalk and is especially beneficial in combination with a leading pedestrian interval.

### ***Bicycle Green Phasing***

<b>Bicycle Green Phasing</b>	
Yellow change interval	3–6 s
Cycle Lengths	60–90 s
Lead Bike Interval	3 s

### ***Transit Signal Priority***

On transit corridors, especially where designated transit lanes are provided, designers should consider signal priority for transit vehicles, which will improve service reliability. This might include detecting approaching transit vehicles or coordinating signal timing for their running speed.

### ***Roundabouts***

Refer to the TEOM for guidance on the evaluation of intersections for roundabouts.

### ***Roundabout Sizing***

<b>Configuration</b>	<b>Design Vehicle</b>	<b>Inscribed Circle Diameter Range</b>
Single-lane roundabout	B-40	90'–120'
	WB-40	100'–130'
	WB-50	105'–150'
	WB-67	130'–180'
Two-lane roundabout	WB-40	135'–160'
	WB-50	150'–220'
	WB-67	165'–220'
Three-lane roundabout	WB-50	200'–250'
	WB-67	220'–300'

Personal mobility facilities in roundabouts should meet or exceed facilities on the approaches. Personal mobility facilities in roundabouts should have a minimum buffer of 2 feet from vehicles (6 feet preferred).

### **Access Management**

#### ***Raised Medians***

Medians control vehicle access points and reduce vehicle speeds by introducing friction. Typically, space within the median is planted or filled with stamped concrete or bricks.

<b>Medians</b>	
Minimum width	4'
Width for pedestrian refuge	6'
Width for bicycle crossing	8'
Two-way left-turn lane width	10'

#### ***Right-in-Right-Out Control***

This guidance is intended only for right-in-right-out driveways and does not encourage “slip lanes” or “right bypass lanes” at intersections. Restricting left turns into and out of driveways can be a common design that helps control the number of potential conflict points at each driveway, thus improving safety. This can be achieved with the geometry of the driveway and adding in a “porkchop” island to restrict left turns or by utilizing a median on the street itself.

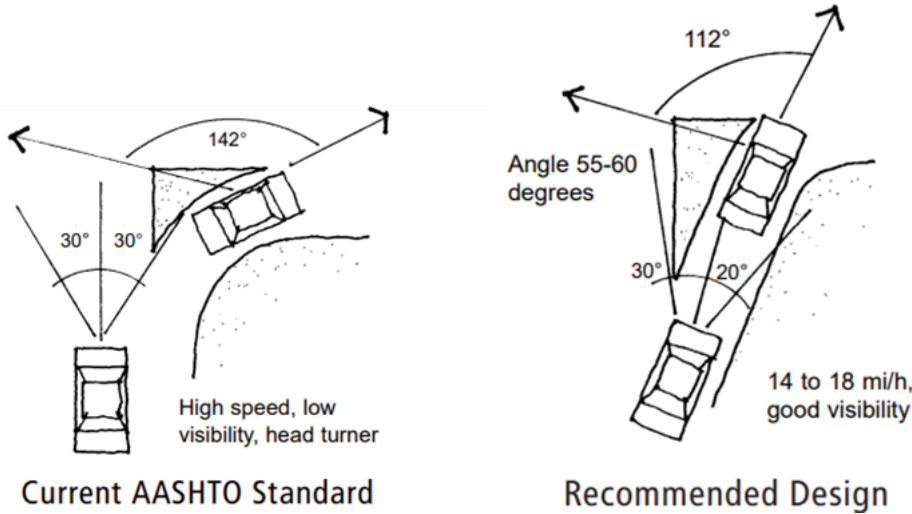

Sketches by Michael Kimelberg

Figure 10 – Principles of Limiting Left Turns at Driveways (FHWA)

**Driveway Spacing**

Driveway Spacing	
Min neighborhood to neighborhood road CL offset	100'
Min connector to connector road CL offset	200'
Maximum deflection from right angle	20°

**Commercial Driveways**

Type of Use	Standard Width		Divided Width **		Median Width (ft)	Driveway Radii ****	
	Min	Max	Min	Max		Min	Max
Commercial/Industrial	24'	30'	14' *	24'	6'	24'	30'
Trucks	24'	30' ***	18' *	30'	6'	24'	30'
Special	18'	30'	24'	30'	2'	18'	30'
Passenger Vehicle	24'	30'	14' *	24'	6'	24'	30'

\*applies to one-way drives only

\*\*width on each side of median

\*\*\*35' for 3 lanes with approval (1 in and 2 out)

\*\*\*\*radii should be justified by plotting vehicle travel path

Driveway grades shall conform to the typical section of the street within the right of way. Any deviations shall be approved by the City with the following limitations:

1. Driveways shall attain a minimum elevation of six inches above the gutter elevation within the right of way with a maximum grade of 8%
2. The maximum algebraic difference in grades within the right of way shall be 8% on crest drives and 12% on sag drives
3. The maximum driveway grade outside right of way shall be 15%

Typology	Min Apron Length	Desirable Grade Change	Max Grade Change Allowed
Industrial	25'–30'	2%–3%	3%–4%
Suburban Commercial Thoroughfare	20'	4%	5%
Downtown Core Urban Mixed-Use Connector	15'	5%	6%

### **Residential Driveways**

Residential Driveway Breakover	Algebraic Difference in grades
Max. sag breakover	12%
Max. crest breakover	8%
Max driveway grade (in R/W)	8%
Max driveway grade (outside R/W)	15%

*\*\*requirement: maintain 6" vertical gutter capacity minimum with driveway design*

### **Cul-De-Sacs**

At locations where streets are to be terminated and a vehicular connection between adjacent streets is not required, the termination shall be a cul-de-sac. Such cul-de-sac shall be constructed with a minimum radius of 50 feet to the back of the curb if there are no islands located in the cul-de-sac. Cul-de-sacs should allow the turn of an SU-30 vehicle without reversing.

Fine-grained connectivity will benefit pedestrians and cyclists. Designers should consider if a cul-de-sac is suitable for a bicycle or pedestrian cut-through to an adjacent street.

# Implementation

## Applying the Streets Design Guide

### When to Use the Streets Design Guide

At every stage of project development there are opportunities to improve street safety. The following graphic presents five stages of the project life cycle with corresponding safety-focused outcomes. The "Opportunities" represent areas to achieve this outcome, and the "Inputs" help to prioritize vulnerable road users, create walkable and bikeable corridors, provide transit opportunities, support economic development, and minimize the likelihood and severity of traffic crashes.

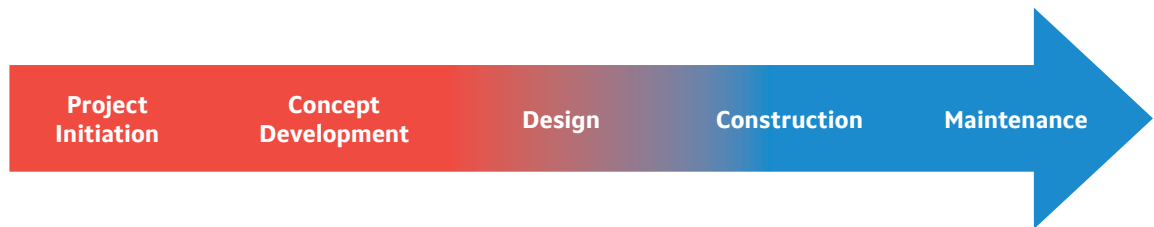

Desired Outcome	Project Initiation	Concept Development	Design	Construction	Maintenance
Shared understanding of purpose and need that prioritizes safety	Selection of preferred alternatives that serves all users	Incorporation of design elements that minimize crash and injury risk	Work Zones that minimize safety risk to workers and road users	Decreased disruption of operations due to infrastructure degradation and obstructions	
<ul style="list-style-type: none"> <li>Make safety a focus of the project from the outset</li> <li>Expand definition of user groups</li> </ul>	<ul style="list-style-type: none"> <li>Half-improvements</li> <li>Road diets</li> <li>Using crash prediction methodologies to compare benefits of alternatives</li> </ul>	<ul style="list-style-type: none"> <li>Inclusion of pedestrian lighting, street furniture, and other amenities</li> <li>Traffic calming measures</li> </ul>	<ul style="list-style-type: none"> <li>Accommodation for vulnerable road users during construction</li> <li>Improved guidance for road users</li> <li>Traffic calming</li> </ul>	<ul style="list-style-type: none"> <li>Faster clearance of obstructions, especially for sidewalks and transit stops</li> </ul>	
<ul style="list-style-type: none"> <li>Crash history</li> <li>Current and projected traffic volumes</li> <li>Land use / zoning</li> <li>Community engagement</li> </ul>	<ul style="list-style-type: none"> <li>Project context and street typology</li> <li>SDG Safe Streets Principles</li> <li>KC Spirit Playbook</li> <li>Community engagement</li> </ul>	<ul style="list-style-type: none"> <li>SDG Design Guidance</li> <li>Multi-disciplinary plan review</li> <li>Traffic and speed study findings</li> </ul>	<ul style="list-style-type: none"> <li>Physical constraints</li> <li>Schedule constraints</li> <li>Traffic control and detour plans</li> <li>Improvement needs for detour routes</li> </ul>	<ul style="list-style-type: none"> <li>Maintenance policies and schedules</li> <li>Public reporting of maintenance concerns</li> <li>Public reporting of safety concerns</li> </ul>	

The “Typologies” section of this Streets Design Guide represents target conditions. Today, Kansas City Streets match these conditions to varying degrees. The purpose of this guide is to:

1. Recognize opportunities to create safer streets
2. Set the desired characteristics of Kansas City streets
3. Guide designers toward the desired characteristics at every opportunity

The following table shows safety-specific design elements discussed in the SDG and how each project type may consider them. In general, if a project significantly impacts one of these design elements, designers should consider improving it to the target condition (as described in the typology tables), especially if such a change does not require utility relocation or additional right-of-way. Consult the TEOM for more information about traffic calming projects and strategies related to traffic control enhancements.

Consideration	Project Type				
	New Construction	Reconstruction	Resurfacing	Utility Work	Traffic Safety
<b>Obtain ROW</b>	Yes, consult MSP	No, unless alignment is changing	No	No, unless utility ROW will change	No
<b>Change Pavement Width</b>	NA: select pavement width to accommodate required elements	Yes, consider reducing pavement width if possible	No	No, unless utility work requires significant reconstruction	No
<b>Add / Improve Pedestrian Facilities</b>	Yes, 10' sidewalks on both sides with buffer	Yes, match typology guidance	No	No, unless work requires rebuilding sidewalk	No
<b>Add / Improve Mobility Facilities</b>	Yes, match typology guidance	Yes, match typology guidance	Yes, match typology guidance	Yes, through road diets	Yes, through road diets
<b>Traffic Safety Enhancements</b>	Yes	Yes	Yes, use temporary materials	Yes, use temporary materials	Yes
<b>Improve Intersections</b>	NA: design intersections for design vehicle and protect pedestrians and cyclists	Yes, make ADA compliant and consider improved crossings, mobility facilities, and new traffic control	Yes, make ADA compliant and consider improved crossings and mobility facilities with temporary materials	Yes, make ADA compliant and consider improved crossings and mobility facilities with temporary materials	Yes, use temporary materials

## ***New Construction***

New streets on greenfield sites present the most flexibility for designers and should be built to match their typology. New construction provides the opportunity for designers to fully address the needs of all user groups, prioritizing safety for vulnerable and disadvantaged road users. With a more inclusive view of potential modes, designers can establish, as a default:

- A low design speed that matches the desired travel speed of the roadway
- Features that reinforce that target speed and warn drivers of potential conflicts
- Safely spaced facilities for pedestrians and cyclists
- Infrastructure for transit services
- Amenities that enhance the street environment

The typical constraint for new construction is project budget. If a design was completed, but not constructed, prior to adoption of this streets design guide, then the City Council members for that district and Public Works Director should be consulted on whether to re-design the road in accordance with this guide or keep the previous design.

## ***Reconstruction***

Reconstructed streets are also relatively easy to align with their typology. However, compared to new construction, they are more likely to be constrained by:

1. Available right-of-way
2. The design of adjacent roadway sections

Regardless of right-of-way constraints, designers must prioritize the safety of vulnerable road users. When sufficient space to separate vulnerable road users is not readily available within the right of way, designers should first look to re-allocate vehicle space to create more separation and/or reduce the target speed so that less separation is necessary.

Design consistency along a corridor helps users understand the street environment and its expectations; therefore, designers may choose to modify the target conditions in a given typology to achieve a thoughtful transition from one segment of a corridor to the next. When making such modifications, designers should consider the likelihood adjacent segments will soon be improved—poor design on adjacent segments is not an excuse to rebuild a poorly designed street.

## ***Resurfacing***

Resurfacing projects are focused primarily on the pavement surface, but also present the opportunity for safety improvements, often at low cost. For example, by changing the location of pavement markings, designers can:

- Reduce the width of unnecessarily wide lanes
- Add a painted median or buffer zone
- Add personal mobility or turn lanes

## ***Utility Work***

When water or other utilities work requires disruption to the pavement or roadside, a Vision Zero review may identify opportunities for enhanced safety. Such improvements require close coordination between City departments and will likely depend on the extent of pavement impacted by the utility work. Every project that impacts street right-of-way should consider possible safety improvements. Even utilities projects with small footprints may provide an opportunity to meet ADA standards, increase access management, provide a midblock crossing, add a speed hump, or enhance signing and striping. Over time, this approach will help bring improved geometric design elements, traffic operations, access, and mode choices to the transportation network throughout the City.

## ***Traffic Safety Projects***

The City can implement systemic safety across its transportation network outside of other capital projects through the City's annual allocation for Vision Zero improvements. These projects can bring impactful safety measures to many locations at once, often at a low cost.

This may include traffic calming treatments, such as:

- Speed humps, bumps, and cushions
- Chicanes
- Curb extensions
- Road diets

It may also include systemic safety treatments, such as:

- High-visibility crosswalk markings
- Traffic signal improvements
- Intersection lighting

## **When to Vary from the Streets Design Guide**

### ***Applicability of Design Variances***

Design variances or exceptions may be requested to modify street design elements outside Kansas City standards and/or the SDG. This variance process applies to designs developed by the City and designs developed by external partners. The City will formally review requests for variances—both at the conceptual phase and completion of 60% plans—to ensure the design will still meet the goals of the SDG.

### **Requirements to Request a Design Variance**

The following information shall be provided with any requests for a design variance:

1. The location and typology of the street segment
2. The desired variance or exception from the SDG
3. A summary of alternatives considered
4. A justification for the variance or exception which considers:
  - a. Safety impacts
  - b. Mobility impacts to pedestrians and bicyclists
  - c. Mobility impacts to emergency and transit vehicles
  - d. Project cost and life cycle maintenance impacts
  - e. Environmental impacts
5. Mitigation measures for any negative impacts identified above

Variances go to the Transportation and Development Committee.

See the website for more information: <https://www.kcmo.gov/city-hall/departments/public-works/public-works-design-construction-standards/transportation-and-development-committee>

### **Standard Guidance**

- A sidewalk width of 10 ft is preferred. Additional space for pedestrians shall be prioritized over additional through lanes and parking lanes.
- An amenity zone, minimum of 4 ft wide, shall be provided between the motor vehicle travel way and sidewalk.
- Parking lanes, where present, should not exceed a width of 8 ft.
- Turning lanes, where present, should not exceed a width of 11 ft.

### **Exceptions to these requirements:**

- If the roadway lanes are 10 ft (or 11 ft on bus routes), then an exception can be made to the 10 ft minimum sidewalk width requirement.
- If in the following street types: Downtown Core, Urban Mixed Use and Connectors, the utility and furnishing zone may encroach up to 4 ft into the sidewalk width to provide a minimum of a 6 ft continuous walking space along the entirety of the street. In this scenario, the widths of the travel and parking lanes shall not exceed the minimums.
- If a 10 ft sidewalk has been provided outside of the amenity zone, then wider than minimum parking lanes and or turning lanes may be considered.
- If there is no opportunity to narrow or remove driving/parking lanes, a pedestrian sidewalk may be constructed at less than 6 ft of continuous clear walking space but not less than 5 ft.

## Supplemental Resources for Street Design

### Coordination Partners

For designs that involve	Coordinate with
Parkways, Boulevards, or Trails	KCPRD and KC Parks Board
Transit Facilities	KCATA
Green Stormwater Infrastructure	KC Water

### Supporting Documents

The following documents were foundational to the Streets Design Guide, and designers are encouraged to refer to them when this guide is unclear. Generally, documents are listed in order of preference for consideration. Documents in bold should take precedence over this guide where conflicts exist.

When designing	Refer to
Any Street	<ul style="list-style-type: none"> <li>KCMO Vision Zero Action Plan</li> <li>KCMO Complete Streets Ordinance (No. 170949)</li> <li>NACTO Urban Street Design Guide</li> <li>NCHRP Human Factors Guide</li> <li>ITE Trip Generation Manual</li> </ul>
Pedestrian Facilities	<ul style="list-style-type: none"> <li><b>ADA PROWAG</b></li> <li>AASHTO Guide for the Planning, Design, and Operation of Pedestrian Facilities</li> <li>Kansas City Sidewalk Prioritization Plan</li> <li>Pedestrian Level of Traffic Stress Assessment (PLTS)</li> </ul>
Micromobility Facilities	<ul style="list-style-type: none"> <li>NACTO Urban Bikeway Design Guide</li> <li>AASHTO Guide for the Development of Bicycle Facilities</li> </ul>
Transit Facilities	<ul style="list-style-type: none"> <li><b>KCATA Standards</b></li> <li>NACTO Transit Street Design Guide</li> </ul>
Vehicular Traveled Ways	<ul style="list-style-type: none"> <li>KCMO Pavement Manual</li> <li>AASHTO Highway Safety Manual</li> <li>AASHTO "Green Book" (Policy on Geometric Design of Highways and Streets)</li> <li>AASHTO Roadside Design Guide</li> </ul>
Boulevards and Parkways	<ul style="list-style-type: none"> <li>KCMO Boulevard and Parkway Standards</li> </ul>
Green Stormwater Infrastructure	<ul style="list-style-type: none"> <li><b>KCMO Green Stormwater Infrastructure Manual</b></li> <li>NACTO Urban Street Stormwater Guide</li> </ul>
Markings, Signing, Lighting, and Devices	<ul style="list-style-type: none"> <li>KCMO Traffic Engineering and Operations Manual</li> <li>APWA 5800</li> </ul>